

Offshore Wind-to-Hydrogen: The Impact of Intermittency on Hydrogen Production and Transport

Eoghan Summers
University of Edinburgh
Gavin & Doherty Geosolutions
Edinburgh, UK

Julia Race
University of Strathclyde,
Glasgow, UK

Dimitri Mignard
University of Edinburgh
Edinburgh, UK

Mi Tian
University of Exeter
Exeter, UK

Mohammed Alaa Almoghayer
University of Strathclyde
Gavin & Doherty Geosolutions
Glasgow, UK

ABSTRACT

Offshore wind is a promising renewable energy source for green hydrogen production, providing a versatile solution for energy storage and power-to-gas concepts. This research investigates how the intermittent nature of offshore wind impacts the components of an offshore wind-to-hydrogen system. Proton exchange membrane electrolyzers are frequently identified as being best suited to integration with intermittent renewables. However, stop-start cycling of current from a variable power supply can damage electrodes and reduce electrolyser lifetime. Therefore, a small current is required during no-wind periods to prevent electrolyser degradation. An intermittent offshore wind resource can also impact pipeline transport of hydrogen. Variable hydrogen production leads to fluctuating hydrogen flow in pipelines. The resulting pressure variations, combined with the potential occurrence of hydrogen embrittlement in steel pipelines, can increase the potential and severity of fatigue crack growth, thereby impacting pipeline integrity. Careful selection of pipeline materials and buffer storage to smoothen gas flows, can mitigate these potential impacts. This research proposes a configuration for hydrogen production on an offshore platform from a floating wind farm. It uses battery and hydrogen storage offshore to provide buffers, mitigating the potential impacts of intermittency on each component of the offshore wind-to-hydrogen system.

Keywords: Green hydrogen; Offshore wind-to-hydrogen; Intermittency; Electrolysis; Offshore hydrogen pipelines

Nomenclature:

AC	Alternating Current
AEL	Alkaline Electrolysis
API	American Petroleum Institute
ASME	American Society of Mechanical Engineers
CAPEX	Capital Expenditure
DC	Direct Current
EMEC	European Marine Energy Centre
GHG	Greenhouse Gas
HE	Hydrogen Embrittlement
LHV	Lower Heating Value
MOP	Maximum Operational Pressure
OCV	Open Circuit Voltage
OWF	Offshore Wind Farm
PE	Polyethylene
PEM	Proton Exchange Membrane
PTL	Porous Transport Layer
RO	Reverse Osmosis
SOE	Solid Oxide Electrolysis
UPS	Uninterruptible Power Supply

1. INTRODUCTION

To avoid the worst effects of climate change, it is widely accepted that immediate and sustained reduction of greenhouse gas (GHG) emissions is required [1]. Hydrogen has significant potential as a clean energy carrier to aid decarbonization. As a clean burning fuel, it can play a role in many hard-to-decarbonise sectors, including transportation and heavy industry, along with current chemical applications in fuel refining and fertilizer production. It also has significant potential for seasonal energy storage, by acting as a dispatchable fuel for power generation, helping balance a grid with a higher share of variable renewable energies.

Historically, hydrogen has been produced from fossil fuels, emitting large amounts of CO₂ in the process. Hydrogen can also be produced via water electrolysis using electricity from a renewable energy source. This form of hydrogen is compatible with net zero targets and is called "green hydrogen" to show that its production is climate friendly [2]. Advances in electrolysis and renewable energy technologies have significantly brought down the price of green hydrogen. With governments pushing the reduction of carbon emissions and looking to ensure their energy security, the demand for green hydrogen has risen quickly and is expected to continue to rise substantially in the coming years [3].

Countries with considerable offshore wind resource are increasingly looking at using it for large scale hydrogen production. Falling offshore wind farm (OWF) costs, the higher capacity of OWF's and falling electrolyser costs suggest that combining OWF's and hydrogen production could constitute an emerging business model [4].

Several studies have made the case for hydrogen production offshore, and transport onshore via pipeline. Hydrogen pipelines have the potential to be more cost efficient for large OWF's and for longer offshore distances [5]. There is also potential to repurpose oil and gas infrastructure, including pipelines, for hydrogen production and transport [6]. The two main configurations for producing hydrogen offshore from OWF's are:

1. Centralized offshore electrolysis: All electrolysers are placed on an offshore substation.
2. Decentralized offshore electrolysis: Each electrolyser is on an individual wind turbine structure. ERM Dolphyn is an example of a project employing this configuration [7].

Renewable sources such as wind or solar have intermittent loads due to seasonal changes in wind or solar intensity. Coupling an intermittent power source with an electrolyser represents one of the main technical challenges of green hydrogen production and transport. For hydrogen production, frequent variations in power input may reduce electrolyser reliability and longevity. For transport of hydrogen in a pipeline, variable hydrogen production can cause a fluctuating flow of hydrogen in the pipeline. The resulting pressure variations can have impacts on pipeline integrity.

This paper will consider the impact of an intermittent offshore wind resource on the configuration and components of an offshore wind to hydrogen system. It will consider a floating OWF, located far from shore in deeper waters, where energy is transmitted onshore via hydrogen pipeline. It will consider a centralized offshore electrolyser for hydrogen production due to the reduced complexity versus a decentralized configuration.

A thorough review of the literature will identify the potential impacts of an intermittent offshore wind resource on the electrolyser and its balance of plant. Similarly, the impacts of fluctuating hydrogen flow in the pipeline will be investigated. A configuration for producing hydrogen from an OWF, including buffer battery and hydrogen storage, will then be proposed to mitigate these potential impacts. Sizing of the buffers, and material selection for the pipeline will then be discussed.

This work is intended as an initial study of intermittencies impact on an offshore wind to hydrogen system as part of an ongoing larger research project.

2. TECHNOLOGIES

This section outlines the key technologies of an offshore wind to hydrogen system that are impacted by an intermittent offshore wind resource. They are as follows:

- Electrolyser system
- Hydrogen pipeline
- Electrical storage

- Hydrogen storage
- Balance of plant

Different technology types will be identified which other studies have outlined as being suitable for an offshore wind to hydrogen system, and a detailed examination of the potential impacts of an intermittent offshore wind resource and methods to mitigate this will be discussed.

2.1 Electrolyser Technology

Electrolysis can be considered the key process in the system. It is a chemical process in which electricity is used to split water into hydrogen and oxygen. There currently exists several different electrolysis technologies, of which the most notable are – alkaline electrolysis (AEL), proton exchange membrane electrolysis (PEM) and solid oxide electrolysis (SOE).

Considering the most suitable electrolyser technology for deployment on an offshore platform, the technologies used in other offshore hydrogen production studies have been analysed. This is shown in table 1.

Table 1: Electrolyser technologies used in previous studies

Electrolyser Type	Reference
PEM	[8], [9], [18] – [22]
AEL, PEM	[5]
PEM, SOE	[13]
AEL, PEM, SOE	[14], [15]
Unspecified	[16], [17]

The literature identifies AEL and PEM electrolysers as being viable candidates for centralized offshore hydrogen production. Whilst the high efficiency of SOE technology is promising, its high operating temperature and constant load requirement makes it incompatible with remote offshore operation [18], hence it has not been considered for this paper.

When choosing between AEL and PEM for offshore hydrogen production, there are several important features to consider (table 2).

Table 2: AEL and pem ELECTROLYSER features for offshore hydrogen production [19], [20]

Feature	AEL	PEM
Electrical Efficiency (LHV)	50 - 68 %	50-68 %
Start-up Time (to nominal load)	< 50 mins	< 20 mins
Load Range	15–100 %	5-120 %
Footprint	0.095 m ² /kW	0.048 m ² /kW
Hydrogen Output pressure	1-30 bar	30-80 bar
CAPEX (system)	500-1000 USD/kW	700-1400 USD/kW

The wide operating range and fast starting speed of PEM electrolyzers make them more suitable for integration with a variable energy source [21]. In addition, PEM systems have a lower footprint than AEL [6], an important factor on an offshore platform with already limited space. Another benefit of PEM is that it can operate at higher pressures than AEL, potentially diminishing the need for postproduction compression [22]. AEL electrolyzers currently have lower CAPEX than PEM, though due to being a newer technology, the cost reduction potential of PEM is higher [19]. Finally, the exemplary safety performance, and the fact that PEM can offer high purity hydrogen at all loads makes it the most suitable electrolyser for deployment offshore. An overview of PEM electrolysis is shown in figure 1.

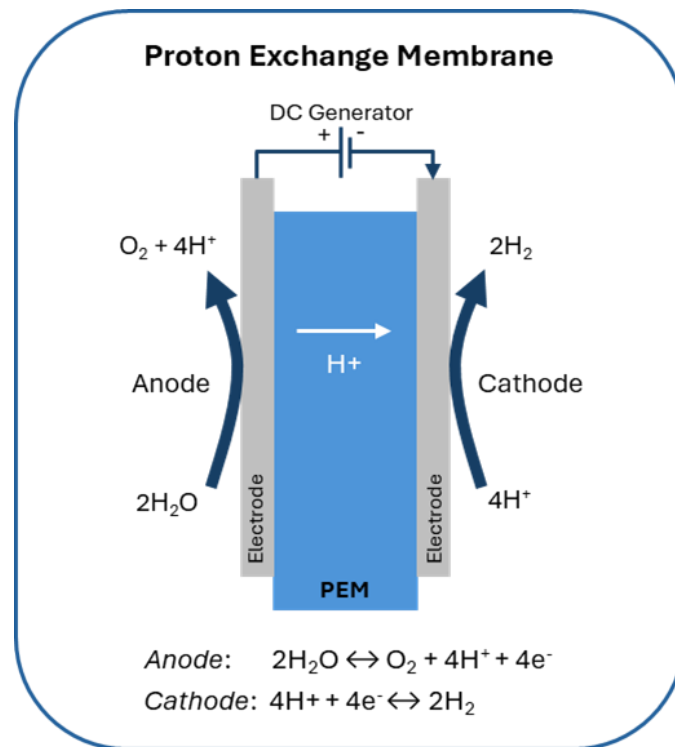

Figure 1: Overview of PEM electrolysis

Despite these features, intermittency can still impact PEM electrolyser performance. The fluctuating power provided from intermittent offshore wind can cause start and stop cycling. This cycling of current can damage electrode materials, decreasing durability and increasing the maintenance periods for the electrolysers. This has been demonstrated in several studies [23], [24], [25], [26], [27].

Wei et al. [23] replicated a fluctuating power supply from an intermittent energy source being fed to a PEM electrolyser, comprising periods of operation at two current densities (high and low) and idle periods where no current was applied and the cell rests at open circuit voltage (OCV). They found that after prolonged cycling (700 cycles), there was a significant decrease in performance, due to the idle periods causing degradation of the catalyst. To prevent this, they recommended applying a small current density, during idle times, to avoid degradation and mitigate safety concerns.

Rakousky et al. [24] investigated the effect of different load profiles to a PEM electrolyser over a 1000h test. They investigated electrolyser performance at a constant current of 1 A cm^{-2} and then 2 A cm^{-2} , and then cycling between 1 and 2 A cm^{-2} and cycling between 2 A cm^{-2} and OCV. They found that cycling between OCV and 2 A cm^{-2} caused electrolyser degradation, with degradation rate increasing with the number of OCV period over the 1000 h test. Again, avoiding idle periods where no current is applied should prevent this higher degradation rate.

Voronova et al. [25] showed that cycling between different loads can impact the electrode materials, potentially causing delamination of the catalyst, porous transport layer (PTL) and membrane layers. These structural changes cause changes in bubble formation characteristics, decreasing cell efficiency and increasing the degradation rate.

In addition, if the power load drops below the electrolyser minimum operating power, the electrolyser will shut down and will take several minutes to restart from cold (up to 20 minutes for PEM). This can lead to a significant amount of wind power needing to be curtailed during start up, which is significant revenue loss [18]. Degradation of the PEM electrolyser can be reduced, and wind curtailment prevented by supplying an uninterruptable power supply (UPS) to the electrolyser during idle wind periods. For offshore hydrogen production, this would require some form of electrical storage on the platform. Electricity storage options will be outlined later.

2.2 Pipeline Technology

Several studies have compared the economic feasibility of using hydrogen versus electricity as energy transmission vectors for offshore wind farms. They identify that for large offshore wind farms, located further from shore, hydrogen transport via pipeline is often better in comparison to electrical alternatives [28], [29], [30]. For example, Gronemans et al. [31] found that for a 15 MW turbine located 60 km offshore, the production of hydrogen offshore ($2.09 \text{ \$ kg}^{-1}$) was lower than the transmission of the electricity to shore, followed by subsequent electrolysis ($3.86 \text{ \$ kg}^{-1}$).

Hydrogen pipelines are not a novel innovation. Existing onshore pipelines are typically found near large hydrogen consumers, such as petroleum refineries and chemical plants [5]. Hydrogen transport via pipeline is typically compared to the transport of natural gas in pipelines. Compared to natural gas, transport of hydrogen poses several challenges which means that materials for the pipelines need to be carefully selected.

One of the main challenges is hydrogen embrittlement (HE). HE is a reduction in the ductility of a metal due to absorbed hydrogen. Being a small element, hydrogen can enter and move through metals, lowering the stress required for cracks in the metal to initiate and propagate. It is a complex process that has several contributing mechanisms, not all of which need to be present. In figure 2, embrittlement is occurring due to hydrogen moving through the metal, until it reaches an area of discontinuity, where it lowers the energy required to make the crack larger. This causes the metal to become more brittle, and to fail easier [6], [32]. Diffusion of hydrogen through the metal means that leakage is another significant challenge. This is also shown in figure 2, with hydrogen escaping to the exterior of the pipeline. Hydrogen's leakage from pipelines is approximately 1.3- to 2.8-times larger than methane leakage under the same conditions [33].

Steel and polyethylene (PE) are the two materials most frequently identified for pipeline transport of 100% hydrogen. PE pipelines are also deemed a good candidate for hydrogen transport at lower pressures, as they are not susceptible to HE and can therefore withstand 100% hydrogen. However, they are unlikely to be suited to the high pressures required for hydrogen transmission pipelines offshore. Leakage of hydrogen due to diffusion is an issue in in PE pipelines [5].

While steel is commonly used for hydrogen transmission pipelines, it can be more susceptible to HE. Mohitpour et al. [34] suggest that the majority of the existing hydrogen transmission lines are of steel grade API 5L X42 (API stands for American Petroleum Institute) or lower and operate between 30 and 60 bar with few failures reported. As the steel grades increase and internal pressure increases, pipelines can become more susceptible to HE. According to the American Society of Mechanical Engineers (ASME) standard B31.12-2019 [207], the maximum operational pressure (MOP) for hydrogen pipes of steel grade API 5L X60 and below, should be less than 207 bar. For all grades above X65, the MOP should be below 103 bar. Therefore, for an offshore hydrogen pipeline, the choice of steel will be dependent on the operating pressure of the pipeline, to prevent HE.

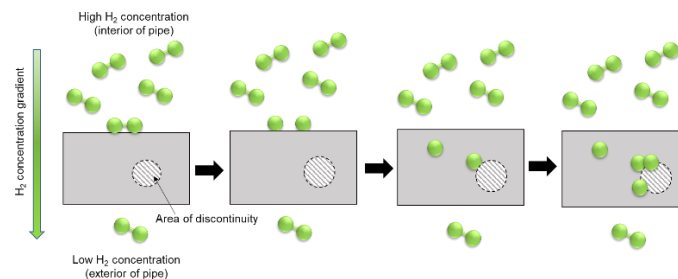

Figure 2: Overview of hydrogen diffusion

Many studies have investigated the potential for reusing existing natural gas pipelines for use with 100% hydrogen. For example, in the UK, most of the distribution network is made from PE, which is considered hydrogen ready at lower pressures. For the UK's transmission network, much of the steel proportions are at grades considered suitable for hydrogen [35]. Around 11% of the transmission pipelines are comprised of higher grade steel pipelines, considered less suitable to hydrogen use without modification [35]. Several studies have investigated the potential for repurposing offshore oil and gas pipelines for hydrogen use. In a study on the reuse of gas pipelines in the North Sea, Jeleňová [6] identified that the majority of natural gas pipelines in the North Sea, built between 1980 and 2000 are

built from steel grades, such as API 5L X52, which are considered suitable for hydrogen storage and transport.

A pressure drop is required to ensure a flow of gas through the pipeline. Various elements affect the magnitude of the pressure drop required, including the length and diameter of the pipe, as well as the surface roughness of the pipe material. In a typical North Sea pipeline, it is estimated that the pipeline experiences a pressure drop of 3-10 bar/100km, though higher values up to 25 bar/km are not considered unusual [36]. Accordingly, hydrogen must be compressed to a suitable pipeline inlet pressure to ensure efficient hydrogen transport. Most PEM technologies have an output pressure of approximately 35 bar (though higher pressures may be achieved in future), which may be a sufficient pressure for pipeline transport [6], though this will be highly dependent on pipeline diameter and distance to shore. Otherwise, a compressor will be required post electrolysis to ensure hydrogen is at a sufficient pressure for pipeline transport.

The intermittency of an offshore wind power supply to the electrolyser will cause variable hydrogen production. Without some form of buffer hydrogen storage before the pipeline, this will cause fluctuating flow of hydrogen along the pipeline. A fluctuating flow of hydrogen will cause changes in pressures and flow rate, potentially impacting pipeline integrity.

A considerable body of research is dedicated to the transient flow of gases in pipelines. For example, there are several studies on the transient operation scenarios that can occur in the pipeline systems for a carbon capture and storage network [37], [38], [39]. Impacts of transient flow include that rapid changes in pressure and flow can induce stress and fatigue in the pipeline material over time, impacting pipeline integrity and potentially resulting in leaks or failures. Pipelines therefore need to be designed to accommodate these pressure fluctuations, ensuring the yield strength of the pipeline is not exceeded.

The impact of transient gas flow in hydrogen pipelines due to an intermittent energy supply is not well investigated. Hydrogen can accelerate fatigue crack growth even at low pressure. Cyclic loading of the pipeline due to variable supply and demand increases the potential and severity of fatigue crack growth. Bouledroua et al. [40] showed that for an API 5L X52 pipeline transporting a natural gas – hydrogen blend, hydrogen embrittlement of the pipeline, together with the transient gas flow and associated transient pressure values, increased the probability of failure of a cracked pipeline. Especially for higher grade steels, lowering the cycle frequency and magnitude can improve the compatibility of the pipeline with hydrogen [32].

For hydrogen production offshore from an intermittent wind resource, the design and material of the pipeline must be able to accommodate fluctuating hydrogen flow. Buffer hydrogen storage could be used to dampen the fluctuating nature of the hydrogen produced before transmission, ensuring a smoother flow of hydrogen in the pipeline, and reducing the pipeline design requirements. This work will outline a possible configuration for transporting hydrogen onshore in a pipeline, using buffer storage to smooth the flow of hydrogen gas in the pipeline.

2.3 Electrical Storage

Electrical storage is required to provide an uninterruptable power supply (UPS) to the electrolyser during no wind periods, or wind periods when loads will be below the minimum operating load of the electrolyser. Electrical storage could also be sized to enable a constant supply of electricity to the electrolyser, thereby enabling constant hydrogen supply to the pipeline. However, this would require a large electrical storage system which may not be feasible offshore. Sizing electrical storage for the system will be discussed further in section 3.

Most hydrogen production concepts rely on battery storage to provide an UPS to the electrolysers. Lithium-ion and redox flow batteries are leading contenders for coupling with electrolyser stacks offshore. Lithium-ion batteries are one of the most common and commercially mature technologies available, offering high energy densities, relatively long cycle life and relatively fast charging capabilities, making them suitable for deployment offshore.

Flow batteries, such as vanadium redox flow batteries, are a newer technology, offering a higher battery cycle life than lithium-ion. This means that for a heavy cycling application, such as offshore wind, they offer a longer lifespan than lithium-ion. Flow batteries have a lower power density than lithium-ion, however they can deliver power for longer, an advantage for longer idle periods when the wind is not blowing. However, flow batteries are currently more expensive, and take up more space – a key consideration on an offshore platform [41]. A project by the European Marine Energy Centre

(EMEC) on Orkney, Scotland, uses vanadium flow batteries to smooth the flow of energy from a tidal turbine to an electrolyser, demonstrating the world's first continuous hydrogen production from variable renewable generation [42]. A similar concept could be used for hydrogen production from offshore wind.

Several offshore wind to hydrogen concepts suggest hydrogen fuel cells as an alternative to battery storage for providing backup power to the electrolyser [7], [18]. The amount of power, and power supply duration that could be stored would be dependent on the accompanying hydrogen tank size. The lower operational efficiency of a fuel cell (around 50-55%) versus battery technologies, may mean that batteries are most suited to provide an UPS to the electrolyser.

2.4 Hydrogen Storage

Buffer hydrogen storage is required to smooth the flow of hydrogen gas along the export pipeline, hence limiting the magnitude and frequency of cyclic stresses. Sizing buffer storage for the system will be discussed in section 3. Hydrogen could be stored offshore in compressed gaseous hydrogen tanks (CH_2) or in liquid hydrogen tanks (LH_2).

Hydrogen storage in liquid form is an expensive form of storage and necessitates the incorporation of a heat exchanger, resulting in increased platform space requirement [43]. Moreover, this approach is ill-suited for buffer storage preceding transportation via a pipeline, given the impracticality of liquefying hydrogen only to revert it back to a gaseous state for pipeline transport.

The most suitable method for storing hydrogen offshore is as a compressed gas in a pressurised vessel. Hydrogen should be stored at the pressure required for the inlet of the pipeline (30-100 bar), so that no additional compression is required to achieve the pressure drop required across the pipeline [18]. Storing hydrogen at higher pressures in a buffer tank would enable larger amounts of hydrogen gas to be stored for the same platform area, but would require more robust construction and stricter safety measures, thereby increasing cost.

Several offshore wind to hydrogen concepts explore the feasibility of using geological storage offshore to store hydrogen before transport onshore via pipeline. This includes a design study by Tractebel Overdick GmbH [44] consisting of large scale offshore hydrogen production from OWF and storage offshore in underground salt caverns. Salt caverns could provide a vast storage capacity, which could optimise flow rates along the pipelines, and provide storage capacity to balance hydrogen supply and demand. However, the geographic availability of suitable salt caverns is limited, and so it has not been considered in this study.

2.5 Balance of Plant

For looking at the potential typologies for hydrogen production offshore, the other main components of an offshore hydrogen production platform have been outlined below.

The electrical components of the system are the large floating OWF, the dynamic cables and array cables, and offshore substation for AC to DC conversion. This connects to a platform containing the PEM electrolyser. This paper gives an overview of components that are affected by an intermittent offshore wind resource. The size, technologies and design used for the floating OWF, cables and substation are out of the scope of this research and are not considered.

The offshore platform containing the electrolyser must also accommodate a desalination unit, as water electrolysis requires high purity water, and freshwater access is an issue offshore. Seawater desalination must be conducted in advance of the electrolyser. Reverse osmosis (RO) is an electrical solution, most frequently identified for offshore deployment and integration with PEM technologies [5], [6]. Hydrogen production costs are only slightly increased by the addition of seawater desalination [19]. A PEM electrolyser allows a hydrogen purifier to be removed from the balance of plant thanks to the hydrogen purity it achieves.

3. Proposed System

Based on a review of the impacted components, a proposed system for mitigating the impacts of intermittency is proposed for producing hydrogen from a floating offshore wind farm (figure 3). This system is for hydrogen production from offshore wind on a centralized offshore platform with electricity being sent to the electrolyser via cable. It provides an initial look at how intermittency can be mitigated

for offshore hydrogen production - future research will focus on exploring its technical and economic feasibility.

3.1 Configuration

The system consists of a large floating wind farm, which transports electricity to an offshore substation and then onto an offshore platform containing the PEM electrolyser and desalination unit. It has a battery storage system located before the electrolyser, which can provide a current to the electrolyser during no wind periods. A hydrogen storage tank is used as a buffer before transport onshore in an export pipeline. The buffer tank ensures a smoother flow of hydrogen along the pipeline and can ensure there is a sufficient pressure drop in the pipeline to allow for an optimal hydrogen flow rate. Depending on the required inlet pressure of the pipeline, a hydrogen compressor may also be required on the platform. Hydrogen is being sent onshore to a storage facility, and end use is out of the scope of this research.

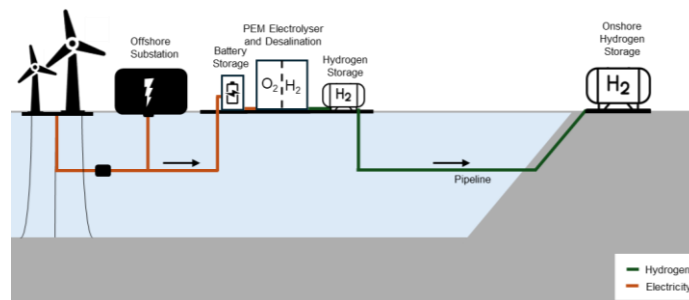

Figure 3: Configuration of an offshore wind to hydrogen system with buffer storage to mitigate intermittency

Due to its suitability to operation with a fluctuating power supply, and smaller footprint, PEM electrolyser have been identified as the most suitable electrolysis technology for deployment offshore. Steel is the likely material of choice for the hydrogen export pipeline, though the grade and design of the material will be dependent on the required pipeline pressure. Identifying a suitable pipeline material and design, as well as the potential of reusing existing offshore gas pipelines are future objectives of this research.

3.2 Sizing Buffer Storage

Sizing the battery storage system, and hydrogen storage tank will be dependent on the specific wind farm and available resource. Future work will initially focus on quantifying the impact of an intermittent energy supply on a PEM electrolyser and hydrogen export pipeline for a case study that has no battery storage or hydrogen storage to form a buffer. This will enable the storage requirement to be better understood so that the storage systems can be sized accordingly.

For sizing the battery storage and hydrogen, the following must be taken into consideration:

- The battery should be sized to provide, at minimum, adequate power to meet all auxiliary power requirements.
- The battery should be sized to provide a small current during idle periods, to prevent electrolyser degradation, as outlined previously.
- The battery could be sized to enable continuous hydrogen production. This could reduce the buffer hydrogen storage required, but the cost of a larger battery may be prohibitive.
- The hydrogen storage tank should be sized to smooth variations in the flow of hydrogen along the pipeline.
- It can also be sized to balance differences in supply and demand. An offshore storage tank could potentially balance day-to-day variations in supply and demand; however, seasonal balancing would require a storage capacity beyond what would be possible on an offshore platform, without including a form of geological storage.

Through future work, quantifying the impacts of intermittency on the system, an optimum design of the battery storage, hydrogen storage and hydrogen pipeline can be proposed to mitigate those impacts.

4. CONCLUSION

Green hydrogen has significant potential as an energy storage medium and as a clean energy carrier in many hard to decarbonize sectors. There is significant ongoing research on coupling offshore wind with hydrogen production via electrolysis. For large offshore wind farms, located further from shore, transporting energy onshore via hydrogen pipeline can be a more cost-effective solution in comparison to electrical alternatives. This report discussed the impact of an intermittent wind resource on the components and configuration of an offshore wind-to-hydrogen system. PEM electrolyzers, frequently identified as being best suited to integration with a variable power source, require a small current during idle periods to prevent electrolyser degradation.

Variable hydrogen production from an intermittent offshore wind source leads to fluctuating hydrogen flow in the export pipeline. The resulting pressure variations, combined with the potential occurrence of hydrogen embrittlement can increase the potential and severity of fatigue crack growth, thereby impacting pipeline integrity. A configuration is proposed for a floating wind farm, PEM electrolyser, battery storage, and hydrogen storage tank, addressing the complexities of fluctuating power supply and hydrogen flow in pipelines. In addition, careful selection of a steel grade for the pipeline is recommended to prevent the likelihood of hydrogen embrittlement occurring. This report is part of a larger research project, with future research aimed at quantifying the impact of intermittency on each component and optimizing system design to mitigate these impacts.

ACKNOWLEDGEMENTS

I would like to acknowledge the funding support of my industrial sponsor - Gavin and Doherty Geosolutions. I would also like to acknowledge the funding support of the Engineering & Physical Sciences Research Council and the Natural Environment Research Council (Grant Number: EP/S023933/1).

REFERENCES

- [1] IPCC, "Climate Change 2023 Synthesis Report," IPCC, Geneva, Switzerland, 2023.
- [2] IRENA, "Making the breakthrough: Green hydrogen policies and technology costs," International Renewable Energy Agency, Abu Dhabi, 2021.
- [3] G. Calado and R. Castro, "Hydrogen Production from Offshore Wind Parks: Current Situation and Future Perspectives," *Applied Sciences*, vol. 11, no. 12, p. 5561, Jun. 2021, doi: 10.3390/app11125561.
- [4] S. McDonagh, S. Ahmed, C. Desmond, and J. D. Murphy, "Hydrogen from offshore wind: Investor perspective on the profitability of a hybrid system including for curtailment," *Applied Energy*, vol. 265, p. 114732, May 2020, doi: 10.1016/j.apenergy.2020.114732.
- [5] O. S. Ibrahim, A. Singlitico, R. Proskovics, S. McDonagh, C. Desmond, and J. D. Murphy, "Dedicated large-scale floating offshore wind to hydrogen: Assessing design variables in proposed typologies," *Renewable and Sustainable Energy Reviews*, vol. 160, p. 112310, May 2022, doi: 10.1016/j.rser.2022.112310.
- [6] D. Jeleňová, "Technoeconomic analysis of offshore green hydrogen production re-using oil and gas infrastructure," University of Strathclyde, 2023. Accessed: Jun. 30, 2023. [Online]. Available: <https://era.ed.ac.uk/handle/1842/39786>
- [7] "ERM Dolphyn Hydrogen Phase 2 final report," *Final Report*, 2021.
- [8] C. Jepma, G.-J. Kok, M. Renz, M. van Schot, and K. Wouters, "Towards sustainable energy production on the North Sea - Green hydrogen production and CO2 storage: onshore or offshore?," Mar. 2018.
- [9] C. Jepma and M. Schot, "On the economics of offshore energy conversion: smart combinations," 2017.
- [10] "Scottish Offshore Wind to Green Hydrogen Opportunity Assessment".

- [11] P. O’Kelly-Lynch, P. Gallagher, A. Borthwick, E. McKeogh, and P. Leahy, “Offshore conversion of wind power to gaseous fuels: Feasibility study in a depleted gas field,” *Proceedings of the Institution of Mechanical Engineers, Part A: Journal of Power and Energy*, vol. 234, no. 2, pp. 226–236, Mar. 2020, doi: 10.1177/0957650919851001.
- [12] “Offshore renewable energy resources and their potential in a green hydrogen supply chain through power-to-gas - Sustainable Energy & Fuels (RSC Publishing).” Accessed: Dec. 21, 2023. [Online]. Available: <https://pubs.rsc.org/en/content/articlelanding/2019/se/c8se00544c>
- [13] K. Meier, “Hydrogen production with sea water electrolysis using Norwegian offshore wind energy potentials,” *Int J Energy Environ Eng*, vol. 5, no. 2, p. 104, May 2014, doi: 10.1007/s40095-014-0104-6.
- [14] A. Spyroudi, D. Wallace, G. Smart, K. Stefaniak, S. Mann, and Z. Kurban, “Offshore Wind and Hydrogen: Solving the Integration Challenge,” *ORE Catapult*, Jul. 2020.
- [15] A. Singlitico, J. Østergaard, and S. Chatzivasileiadis, “Onshore, offshore or in-turbine electrolysis? Techno-economic overview of alternative integration designs for green hydrogen production into Offshore Wind Power Hubs,” *Renewable and Sustainable Energy Transition*, vol. 1, p. 100005, Aug. 2021, doi: 10.1016/j.rset.2021.100005.
- [16] M. Leporini, B. Marchetti, F. Corvaro, and F. Polonara, “Reconversion of offshore oil and gas platforms into renewable energy sites production: Assessment of different scenarios,” *Renewable Energy*, vol. 135, pp. 1121–1132, May 2019, doi: 10.1016/j.renene.2018.12.073.
- [17] P. Blanco-Fernández and F. Pérez-Arribas, “Offshore Facilities to Produce Hydrogen,” *Energies*, vol. 10, no. 6, Art. no. 6, Jun. 2017, doi: 10.3390/en10060783.
- [18] D. Niblett, M. Delpisheh, S. Ramakrishnan, and M. Mamlouk, “Review of next generation hydrogen production from offshore wind using water electrolysis,” *Journal of Power Sources*, vol. 592, p. 233904, Feb. 2024, doi: 10.1016/j.jpowsour.2023.233904.
- [19] IRENA, “Green hydrogen cost reduction: Scaling up electrolyzers to meet the 1.5C climate goal,” International Renewable Energy Agency, Abu Dhabi, 2020.
- [20] IEA, “The Future of Hydrogen,” G20, Japan, Jun. 2019.
- [21] M. Carmo, D. L. Fritz, J. Mergel, and D. Stolten, “A comprehensive review on PEM water electrolysis,” *International Journal of Hydrogen Energy*, vol. 38, no. 12, pp. 4901–4934, Apr. 2013, doi: 10.1016/j.ijhydene.2013.01.151.
- [22] A. Buttler and H. Spliethoff, “Current status of water electrolysis for energy storage, grid balancing and sector coupling via power-to-gas and power-to-liquids: A review,” *Renewable and Sustainable Energy Reviews*, vol. 82, pp. 2440–2454, Feb. 2018, doi: 10.1016/j.rser.2017.09.003.
- [23] A. Weiß, A. Siebel, M. Bernt, T.-H. Shen, V. Tileli, and H. A. Gasteiger, “Impact of Intermittent Operation on Lifetime and Performance of a PEM Water Electrolyzer,” *J. Electrochem. Soc.*, vol. 166, no. 8, p. F487, Apr. 2019, doi: 10.1149/2.0421908jes.
- [24] C. Rakousky *et al.*, “Polymer electrolyte membrane water electrolysis: Restraining degradation in the presence of fluctuating power,” *Journal of Power Sources*, vol. 342, pp. 38–47, Feb. 2017, doi: 10.1016/j.jpowsour.2016.11.118.
- [25] A. Voronova, H.-J. Kim, J. H. Jang, H.-Y. Park, and B. Seo, “Effect of low voltage limit on degradation mechanism during high-frequency dynamic load in proton exchange membrane water electrolysis,” *International Journal of Energy Research*, vol. 46, no. 9, pp. 11867–11878, 2022, doi: 10.1002/er.7953.
- [26] S. Sood *et al.*, “Generic Dynamical Model of PEM Electrolyser under Intermittent Sources,” *Energies*, vol. 13, no. 24, Art. no. 24, Jan. 2020, doi: 10.3390/en13246556.
- [27] V. A. Martinez Lopez, H. Ziar, J. W. Haverkort, M. Zeman, and O. Isabella, “Dynamic operation of water electrolyzers: A review for applications in photovoltaic systems integration,” *Renewable and Sustainable Energy Reviews*, vol. 182, p. 113407, Aug. 2023, doi: 10.1016/j.rser.2023.113407.
- [28] R. d’Amore-Domenech, T. J. Leo, and B. G. Pollet, “Bulk power transmission at sea: Life cycle cost comparison of electricity and hydrogen as energy vectors,” *Applied Energy*, vol. 288, p. 116625, Apr. 2021, doi: 10.1016/j.apenergy.2021.116625.
- [29] B. Miao, L. Giordano, and S. H. Chan, “Long-distance renewable hydrogen transmission via cables and pipelines,” *International Journal of Hydrogen Energy*, vol. 46, no. 36, pp. 18699–18718, May 2021, doi: 10.1016/j.ijhydene.2021.03.067.

- [30] B. A. Franco, P. Baptista, R. C. Neto, and S. Ganilha, "Assessment of offloading pathways for wind-powered offshore hydrogen production: Energy and economic analysis," *Applied Energy*, vol. 286, p. 116553, Mar. 2021, doi: 10.1016/j.apenergy.2021.116553.
- [31] H. Groenemans, G. Saur, C. Mittelsteadt, J. Lattimer, and H. Xu, "Techno-economic analysis of offshore wind PEM water electrolysis for H₂ production," *Current Opinion in Chemical Engineering*, vol. 37, p. 100828, Sep. 2022, doi: 10.1016/j.coche.2022.100828.
- [32] SGN, "Aberdeen Vision Project Final Report," May 2020.
- [33] Z. Labidine Messaoudani, F. Rigas, M. D. Binti Hamid, and C. R. Che Hassan, "Hazards, safety and knowledge gaps on hydrogen transmission via natural gas grid: A critical review," *International Journal of Hydrogen Energy*, vol. 41, no. 39, pp. 17511–17525, Oct. 2016, doi: 10.1016/j.ijhydene.2016.07.171.
- [34] M. Mohitpour, H. Golshan, and A. Murray, "Specialty Fluid Transmission," in *Pipeline Design and Construction*, ASME Press, 2007.
- [35] ARUP, "Future of UK Gas Networks," Final Report, Oct. 2023.
- [36] N. G. Diez, S. van der Meer, J. Bonetto, and A. Herwijn, "Technical assessment of Hydrogen transport, compression, processing offshore," May 2020.
- [37] H. Aghajani, J. M. Race, B. Wetenhall, E. Sanchez Fernandez, M. Lucquiaud, and H. Chalmers, "On the potential for interim storage in dense phase CO₂ pipelines," *International Journal of Greenhouse Gas Control*, vol. 66, pp. 276–287, Nov. 2017, doi: 10.1016/j.ijggc.2017.06.002.
- [38] L. Klinkby, C. M. Nielsen, E. Krogh, I. E. Smith, B. Palm, and C. Bernstone, "Simulating rapidly fluctuating CO₂ flow into the Vedsted CO₂ pipeline, injection well and reservoir," *Energy Procedia*, vol. 4, pp. 4291–4298, Jan. 2011, doi: 10.1016/j.egypro.2011.02.379.
- [39] B. Wiese, M. Nimtz, M. Klatt, and M. Kühn, "Sensitivities of injection rates for single well CO₂ injection into saline aquifers," *Geochemistry*, vol. 70, pp. 165–172, Aug. 2010, doi: 10.1016/j.chemer.2010.05.009.
- [40] B. Omar, Z. Hafsi, M. Djukic, and S. Elaoud, "The synergistic effects of hydrogen embrittlement and transient gas flow conditions on integrity assessment of a precracked steel pipeline," *International Journal of Hydrogen Energy*, vol. 45, May 2020, doi: 10.1016/j.ijhydene.2020.04.262.
- [41] H. Bai and Z. Song, "Lithium-ion battery, sodium-ion battery, or redox-flow battery: A comprehensive comparison in renewable energy systems," *Journal of Power Sources*, vol. 580, p. 233426, Oct. 2023, doi: 10.1016/j.jpowsour.2023.233426.
- [42] "Eday Flow Battery Project: EMEC: European Marine Energy Centre." Accessed: Jan. 07, 2024. [Online]. Available: <https://www.emec.org.uk/projects/hydrogen-projects/eday-flow-battery-project/>
- [43] Y. Wang, J. Kowal, M. Leuthold, and D. U. Sauer, "Storage System of Renewable Energy Generated Hydrogen for Chemical Industry," *Energy Procedia*, vol. 29, pp. 657–667, 2012, doi: 10.1016/j.egypro.2012.09.076.
- [44] "World's first offshore hydrogen storage concept developed by Tractebel and partners." Accessed: Feb. 28, 2024. [Online]. Available: <https://tractebel-engie.com/en/news/2021/world-s-first-offshore-hydrogen-storage-concept-developed-by-tractebel-and-partners>