



## OPEN ACCESS

## EDITED BY

Xiongbo Duan,  
Central South University, China

## REVIEWED BY

Nihat Ozturk,  
Gazi University, Türkiye  
Tao Qin,  
Hunan University, China

## \*CORRESPONDENCE

Weiqliang Liao,  
✉ wq\_liao@jmu.edu.cn

RECEIVED 26 January 2024

ACCEPTED 22 April 2024

PUBLISHED 30 May 2024

## CITATION

Dong X, Wang H, Zhang C, Yu W, Yang R, Xiao L,  
Liao W and Luo C (2024), The power flow  
algorithm for AC/DC microgrids based on  
improved unified iteration method.  
*Front. Energy Res.* 12:1376714.  
doi: 10.3389/fenrg.2024.1376714

## COPYRIGHT

© 2024 Dong, Wang, Zhang, Yu, Yang, Xiao, Liao  
and Luo. This is an open-access article  
distributed under the terms of the [Creative  
Commons Attribution License \(CC BY\)](#). The use,  
distribution or reproduction in other forums is  
permitted, provided the original author(s) and  
the copyright owner(s) are credited and that the  
original publication in this journal is cited, in  
accordance with accepted academic practice.  
No use, distribution or reproduction is  
permitted which does not comply with these  
terms.

# The power flow algorithm for AC/DC microgrids based on improved unified iteration method

Xin Dong<sup>1</sup>, Haibin Wang<sup>2</sup>, Changkun Zhang<sup>1</sup>, Wanneng Yu<sup>1,3</sup>,  
Rongfeng Yang<sup>1,3</sup>, Longhai Xiao<sup>1,3</sup>, Weiqliang Liao<sup>1,3,4\*</sup> and  
Chenghan Luo<sup>1</sup>

<sup>1</sup>School of Marine Engineering, Jimei University, Xiamen, China, <sup>2</sup>Department of Naval Architecture, Ocean and Marine Engineering, University of Strathclyde, Glasgow, United Kingdom, <sup>3</sup>Marine Engineering College and Key Laboratory of Fujian Province Marine and Ocean Engineering, Jimei University, Xiamen, China, <sup>4</sup>Innovation Laboratory for Sciences and Technologies of Energy Materials of Fujian Province, Xiamen, China

In response to the complexity of the Jacobian matrix inversion process in the power flow algorithm for AC/DC microgrids, leading to large memory requirements and susceptibility to convergence issues, a novel power flow algorithm based on an improved unified iteration method for AC/DC microgrids is proposed. Firstly, the fundamental equations of the unified iteration method and the characteristics of DC systems are analyzed. The reactive power correction terms and voltage phase correction differences are removed from the modified equations of the unified iteration method, and result in a reduction in the order of the Jacobian matrix in the power flow algorithm. Subsequently, the improved IEEE 11-node system is subjected to simulation verification to attain precise power flow solutions for hybrid AC/DC microgrids. The theoretical analysis identifies the main influencing parameters of active and reactive power errors and assesses their impact factors. Finally, experimental validation of the improved power flow algorithm is carried out on a physical platform, clarifying the applicability range of the proposed method. The research results indicate that within allowable error margins, the proposed approach reduces the difficulty of Jacobian matrix inversion, resulting in an 80% increase in computational speed compared to the unified iteration method. It is suitable for microgrid systems with short electrical distances and small magnitudes of node voltage amplitudes and phase differences.

## KEYWORDS

hybrid ac/dc microgrid, power flow algorithm, system characteristics, unified iteration method, matrix reduction

## 1 Introduction

In the context of “carbon peak” and “carbon neutrality,” the penetration of distributed generation technology in the power grid is gradually increasing, and microgrids have become an effective form of utilizing distributed generation technology (Song et al., 2021; Zou et al., 2022). Hybrid AC/DC microgrids, combining the advantages of both AC and DC microgrids, have become an important direction in the development of microgrid technology. However, there exist complex coupling relationships between AC and DC within the system. Therefore, how to systematically analyze AC/DC microgrids and ensure their safe and stable operation has become a focal research area for scholars worldwide (Liu K. et al., 2019; Hameed et al., 2019; Yang et al., 2019).

Power flow analysis, as one of the fundamental tools for microgrid analysis, its mathematical essence involves solving a set of multivariate nonlinear equations through iterative computations to determine parameters such as voltage, phase angle, and power at various nodes (or buses) within the grid. Power flow analysis is employed to ascertain load distribution, voltage stability, line power losses, and flow distribution of components such as generators, transformers, and transmission lines within the power system (Guoqing et al., 2017; Pengfei, 2022), plays a crucial role in microgrid planning, stability calculations, and fault analysis (Bajpai, 2023; Heidary et al., 2023; Huang et al., 2023; Li et al., 2023). Currently, commonly used power flow calculation methods for AC/DC microgrids include the unified iteration method (UIM) and the alternate iteration method (Nejabatkhah et al., 2019; Song et al., 2023). The alternate iteration method separately solves power flow for AC and DC subsystems, providing fast calculation speeds but relatively lower convergence accuracy. On the other hand, the unified iteration method extends the dimension of the Jacobian matrix by introducing DC variables, allowing for the joint solution of variables in AC and DC systems. However, this increases the order of the Jacobian matrix, requiring matrix decomposition in each iteration, thereby adding to the overall computation time (Wang et al., 2018). Therefore, reducing computational complexity and time in the power flow calculation process while ensuring accuracy has become an important aspect of research on power flow calculation in hybrid AC/DC microgrids.

To enhance the efficiency of AC/DC microgrid power flow calculations, related research has primarily focused on improving existing methods. Reference (Liu et al., 2021) proposed a control mode for distributed grids participating in voltage and frequency regulation based on the Newton-Raphson method. On this basis, it introduced a sequential algorithm framework for handling coupling relationships between AC and DC microgrids. Using an improved Newton-Raphson sub-algorithm, it iteratively solved power flow for hybrid AC/DC microgrids. Reference (Ju et al., 2022) presented a fully Distributed Power Flow (DPF) method, transforming nonsmooth constraints into smooth functions. It employed a two-level Augmented Lagrangian Alternating Direction Inexact Newton (ALADIN) method with second-order convergence speed to convert the DPF problem into a distributed step-size optimization problem. By exchanging microgrid boundary information, it achieved accurate power flow results and improved convergence speed and accuracy through the second-level step-size optimization. Reference (Chen et al., 2017) established a steady-state power flow model for a Droop-type distributed power source and AC/DC inverter. It applied a sequence component conversion based on voltage symmetry at the grid connection point and used a sequence current compensation method to decouple the AC subgrid into three-sequence networks, solving them in parallel and further reducing the solution capacity.

While the above literature has improved computational accuracy and speed through enhancements to existing methods, it does not address the impact of DC system characteristics on power flow calculation equations. To address this gap, this paper first comprehensively considers DC system characteristics and proposes an AC/DC microgrid power flow algorithm based on the unified iteration method. This resolves the issues of long computation times and high computational capacity associated with the unified iteration power flow calculation method. Subsequently, through simulation

experiments on the IEEE 11-node system, the effectiveness and high computational efficiency of the proposed algorithm are validated. The study identifies the factors and extent of error generation under different conditions. Finally, experimental verification on a 30 kW load and 70 kW load is conducted on the experimental platform, confirming the feasibility of the improved algorithm.

## 2 The power flow algorithm for AC/DC systems and its improvement

In an AC/DC microgrid, which includes both AC and DC lines, the selection of DC lines leads to variations in system structure and operational modes. Consequently, there are differences in the equivalent models and DC equations.

Taking a two-terminal bipolar DC transmission system as an example, the selected DC line model is systematically modeled (Yang et al., 2021; Zhu et al., 2022), resulting in the equivalent circuit of the DC system as illustrated in Figure 1:

From the equivalent circuit shown in Figure 1, the expressions for the main parameters of the DC line can be obtained as follows:

$$I_d = \frac{3\sqrt{2}E_r \cos \alpha / \pi - 3\sqrt{2}E_i \cos \beta / \pi}{d_{xr} + R_1 + d_{xi}} \quad (1)$$

$$\begin{cases} P_{dr} = U_{dr} I_d \\ P_{di} = U_{di} I_d = P_{dr} - I_d^2 R_1 \end{cases} \quad (2)$$

$$\begin{cases} U_{dr} = 3\sqrt{2} E_r \cos \alpha / \pi - I_d d_{xr} \\ U_{di} = 3\sqrt{2} E_i \cos \beta / \pi + I_d d_{xi} \\ U_{dr} = U_{di} + I_d R_1 \end{cases} \quad (3)$$

Eqs 1–3 form the main parameter equations for the two-terminal bipolar DC transmission system.

For a hybrid AC/DC system model with a total of  $n$  nodes, let the number of DC nodes be  $n_d$ , and the number of AC nodes be  $n_a = n - n_d$ . To facilitate the construction of correction equations, the nodes of the system are numbered as follows: the first  $n_a$  nodes are labeled as AC nodes, and the remaining  $n_d$  nodes are labeled as DC nodes.

For a pure AC system with  $n_a$  nodes, the power equations and correction equations in the polar coordinate form of the Newton-Raphson method are expressed as Eqs 4, 5, respectively.

$$\begin{cases} \Delta P_i = P_i - U_i \sum_{j=1}^n U_j (G_{ij} \cos \delta_{ij} + B_{ij} \sin \delta_{ij}) & i = 1, 2, \dots, n_a \\ \Delta Q_i = Q_i - U_i \sum_{j=1}^n U_j (G_{ij} \sin \delta_{ij} - B_{ij} \cos \delta_{ij}) & i = 1, 2, \dots, n_a \end{cases} \quad (4)$$

$$\begin{pmatrix} \Delta P_a \\ \Delta Q_a \end{pmatrix} = - \begin{pmatrix} H_{aa} & N_{aa} \\ M_{aa} & L_{aa} \end{pmatrix} \begin{pmatrix} \Delta \delta_a \\ \Delta U_a / U_a \end{pmatrix} = -[J] \begin{pmatrix} \Delta \delta_a \\ \Delta U_a / U_a \end{pmatrix} \quad (5)$$

Where the subscript ‘ $a$ ’ represents AC variables;  $\Delta P_a = [\Delta P_1 \Delta P_2 \dots \Delta P_{n_a}]^T$ ,  $\Delta Q_a = [\Delta Q_1 \Delta Q_2 \dots \Delta Q_{n_a}]^T$ ,  $H_{aa}$ ,  $N_{aa}$ ,  $M_{aa}$ ,  $L_{aa}$  are the sub-matrix of partial derivatives of the quantity to be corrected with respect to the correction variables, such as  $H_{aa} = \partial \Delta P_a / \partial \delta_a$ ,  $N_{aa} = (\partial \Delta P_a / \partial U_a) \times U_a$ .

The power equations of the UIM are established based on the power equations of the AC system, with the inclusion of DC variables (Peng et al., 2017; Liu K et al., 2019; Lin et al., 2020; Wang et al., 2023). Combining the proposed DC model, the power

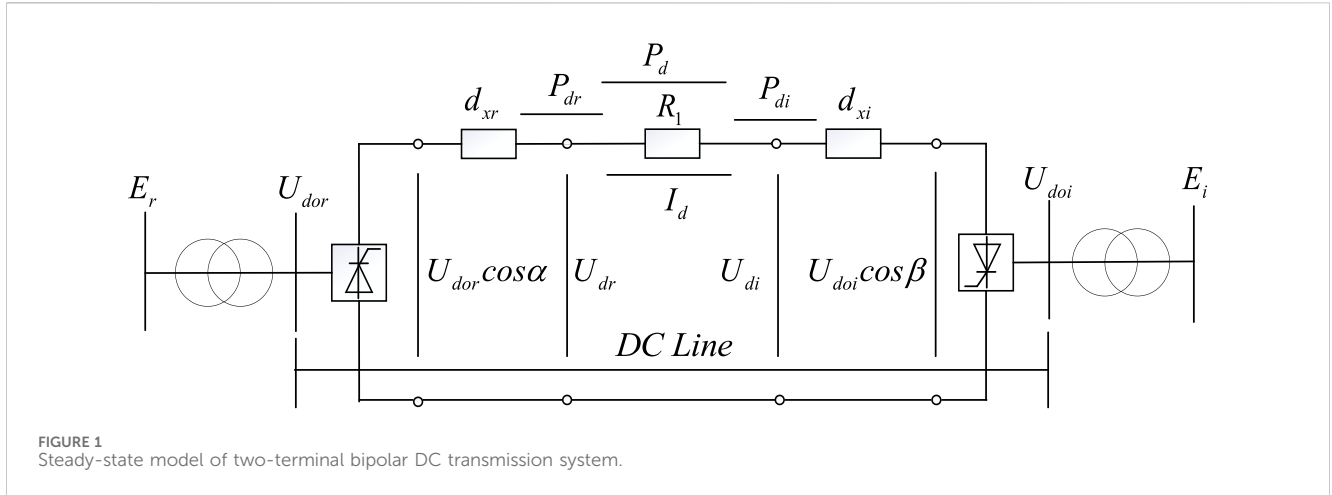

FIGURE 1 Steady-state model of two-terminal bipolar DC transmission system.

equation for the hybrid AC/DC system is obtained by introducing DC variables into Eq. 4, as shown in Eq. 6:

$$\begin{cases} \Delta P_i = P_i - U_i \sum_{j=1}^n U_j (G_{ij} \cos \delta_{ij} + B_{ij} \sin \delta_{ij}) \\ \pm U_{dk} I_{dk}, i = n_d + k, k = 1, 2, \dots, n_d \\ \Delta Q_i = Q_i - U_i \sum_{j=1}^n U_j (G_{ij} \sin \delta_{ij} - B_{ij} \cos \delta_{ij}) \\ \pm U_{dk} I_{dk} \tan \varphi_k, i = n_d + k, k = 1, 2, \dots, n_d \end{cases} \quad (6)$$

Where the positive and negative signs represent the inverter and rectifier, respectively.

Considering the presence of DC variables in the mixed AC/DC system, in Eq. 5, active power and reactive power imbalance terms for the DC nodes, as well as phase difference and voltage difference, are introduced. From Eq. 6, it can be observed that the correction equations introduce new variables  $U_{dk}$ ,  $I_{dk}$ ,  $\varphi_k$ . At this point, the number of variables exceeds the number of equations. According to the theory of the boundedness of solutions in a linear space, it is necessary to supplement the correction equations with new equations to ensure that the number of equations is greater than or equal to the number of variables.

Combining Eqs 1–3, supplement the parameter equation  $\Delta Z_p$  and control equation  $\Delta Z_c$  for the DC system in the quantity to be corrected, and express them uniformly as  $\Delta Z$ .

Rearranging Eq. 3 and forming the parameter equation  $\Delta Z_p$  for the DC system is shown in Eq. 7 (Chen et al., 2019; Lee et al., 2020):

$$\Delta Z_p = \begin{cases} U_{dr} - 3\sqrt{2} E_r \cos \alpha / \pi + I_d d_{xr} = 0 \\ U_{di} - 3\sqrt{2} E_i \cos \beta / \pi - I_d d_{xi} = 0 \\ U_{dr} - R_l I_d - U_{di} = 0 \end{cases} \quad (7)$$

The main control equation for the DC system is expressed as Eq. 8:

$$\Delta Z_c = \begin{cases} P - P_s = 0 \\ \beta - \beta_s = 0 \\ \alpha - \alpha_s = 0 \\ I_d - I_s = 0 \\ U_d - U_s = 0 \\ K_r - K_s = 0 \\ K_i - K_s = 0 \end{cases} \quad (8)$$

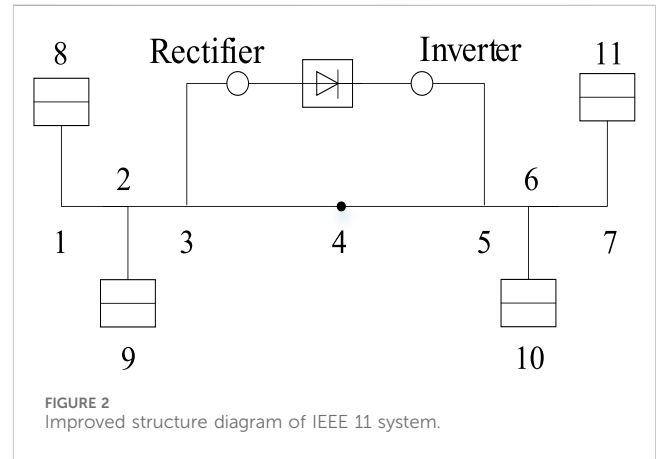

FIGURE 2 Improved structure diagram of IEEE 11 system.

Where the variables with subscript's' represent the system rated values;  $\Delta Z_c$  is determined based on the specific control method.

Due to the increase in the quantity to be corrected on the left side of the correction equation, and with only phase difference and voltage difference in the correction discrepancy, it is still not possible to solve the correction equation. Considering the inclusion of Eqs 7, 8 in the quantity to be corrected, and incorporating the characteristic parameters of the DC system, the correction discrepancy for the DC system is expanded by introducing the correction variable  $\Delta X$ . The specific expression is shown in Eq. 9.

$$\Delta X = [\Delta U_d^T \Delta I_d^T \Delta K_d^T \Delta W^T \Delta \Phi^T]^T \quad (9)$$

The specific expressions for each variable in  $\Delta X$  are shown in Eq. 10:

$$\begin{cases} \Delta U_d = [\Delta U_{d1} \Delta U_{d2} \Delta U_{d3} \dots \Delta U_{dn_d}]^T \\ \Delta I_d = [\Delta I_{d1} \Delta I_{d2} \Delta I_{d3} \dots \Delta I_{dn_d}]^T \\ \Delta K_T = [\Delta K_{T1} \Delta K_{T2} \Delta K_{T3} \dots \Delta K_{Tn_d}]^T \\ \Delta W = [\Delta \cos \theta_{d1} \Delta \cos \theta_{d2} \dots \Delta \cos \theta_{dn_d}]^T \\ \Delta \Phi = [\Delta \varphi_1 \Delta \varphi_2 \Delta \varphi_3 \dots \Delta \varphi_{n_d}]^T \end{cases} \quad (10)$$

Thus, the correction equation for the UIM in the mixed AC/DC system is:

TABLE 1 AC line parameters.

Branch number	Start node	End node	Resistance	Reactance	Branch type
1	1	2	0.0025	0.025	Line
2	1	8	0	0.0167	Transformer
3	2	3	0.001	0.01	Line
4	2	9	0	0.0167	Transformer
5	3	4	0.006	0.055	Line
6	4	5	0.006	0.055	Line
7	5	6	0.001	0.01	Line
8	6	7	0.0025	0.025	Line
9	6	10	0	0.0167	Transformer
10	7	11	0	0.0167	Transformer

TABLE 2 DC line parameters.

Node number	Control angle	Active power	DC current	Commutation reactance	DC resistance
3	0.324	0	2.203	0.015	0.04
5	0.383	1.809	2.203	0.015	0.04

TABLE 3 Comparison of calculation time.

Power flow calculation method	Calculate time/s	Number of iterations/times
UIM	0.02	5
IUIM	0.004	5

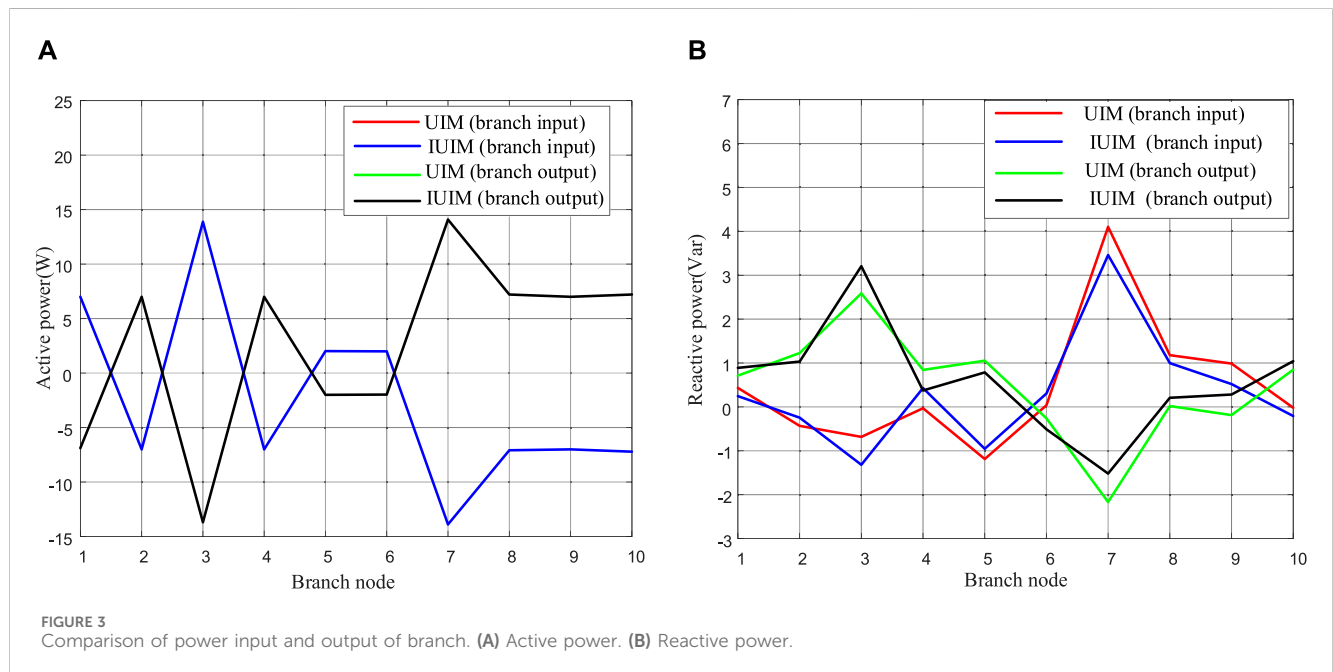

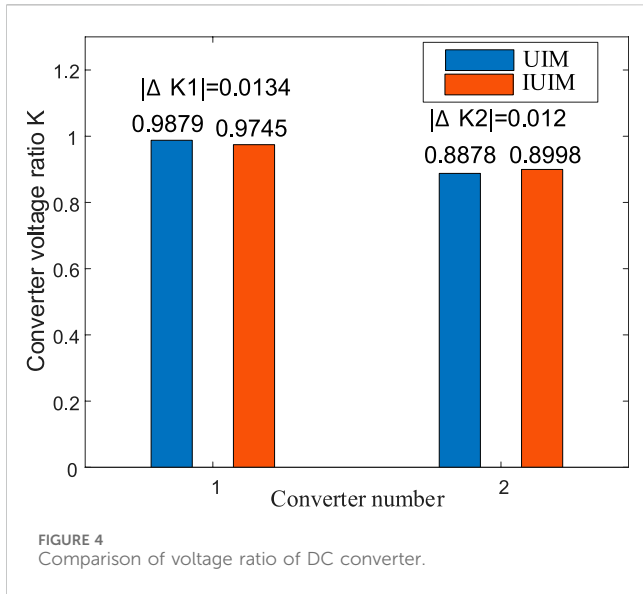

FIGURE 4 Comparison of voltage ratio of DC converter.

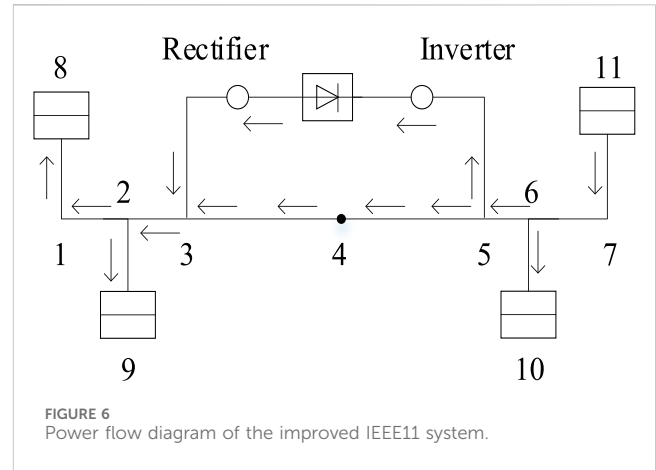

FIGURE 6 Power flow diagram of the improved IEEE11 system.

increase in the order of the Jacobian matrix can complicate the process of solving the inverse matrix, potentially leading to singular values and causing non-convergence of the calculation results. Additionally, it occupies a considerable amount of computational memory and increases the power flow computation time, necessitating improvements.

In DC lines, the power factor is determined by factors  $\cos \varphi = 1$  and  $Q = UI \sin \varphi$ . Meanwhile, only resistive loads are effective in DC circuits, and during power flow analysis, only steady-state changes need to be considered. Therefore, in DC, only active power consumption is considered, and the flow of reactive power is not taken into account. As a result, there is no need for iterative calculations for the variable  $\Delta Q_d$  in the quantity to be corrected.

At the same time, when transmitting electric energy in DC form, due to the special characteristics of DC power supply, there is no induction of reactance in the line during the energy transmission process, and there is no issue of voltage phase angle. For the DC portion in the mixed AC/DC system, there is no need to consider the phase deviation  $\Delta \delta_d$  in the correction discrepancy, which means

$$\begin{pmatrix} \Delta P_a \\ \Delta P_d \\ \Delta Q_a \\ \Delta Q_d \\ \Delta Z \end{pmatrix} = - \begin{pmatrix} H_{aa} & H_{ad} & N_{aa} & N_{ad} & 0 \\ H_{da} & H_{dd} & N_{da} & N_{dd} & A \\ M_{aa} & M_{ad} & L_{aa} & L_{ad} & 0 \\ M_{da} & M_{dd} & L_{da} & L_{dd} & B \\ 0 & 0 & 0 & C & D \end{pmatrix} \begin{pmatrix} \Delta \delta_a \\ \Delta \delta_d \\ \Delta U_a/U_a \\ \Delta U_d/U_d \\ \Delta X \end{pmatrix} = -[J'] \begin{pmatrix} \Delta \delta_a \\ \Delta \delta_d \\ \Delta U_a/U_a \\ \Delta U_d/U_d \\ \Delta X \end{pmatrix} \quad (11)$$

Among them,  $A = \partial \Delta P_d / \partial X$ ;  $B = \partial \Delta Q_d / \partial X$ ;  $C = (\partial \Delta Z / \partial U_d) \times U_d$ ;  $D = \partial \Delta Z / \partial X$ ; Where the elements of the sub-matrices  $H$ ,  $N$ ,  $M$ , and  $L$  in  $J'$  are the same as those in Eq. 5.

Compared to the Jacobian matrix  $J$  in Eq. 5, the order of the augmented Jacobian matrix  $J'$  in Eq. 11 has increased by  $5 \times n_d$ . The

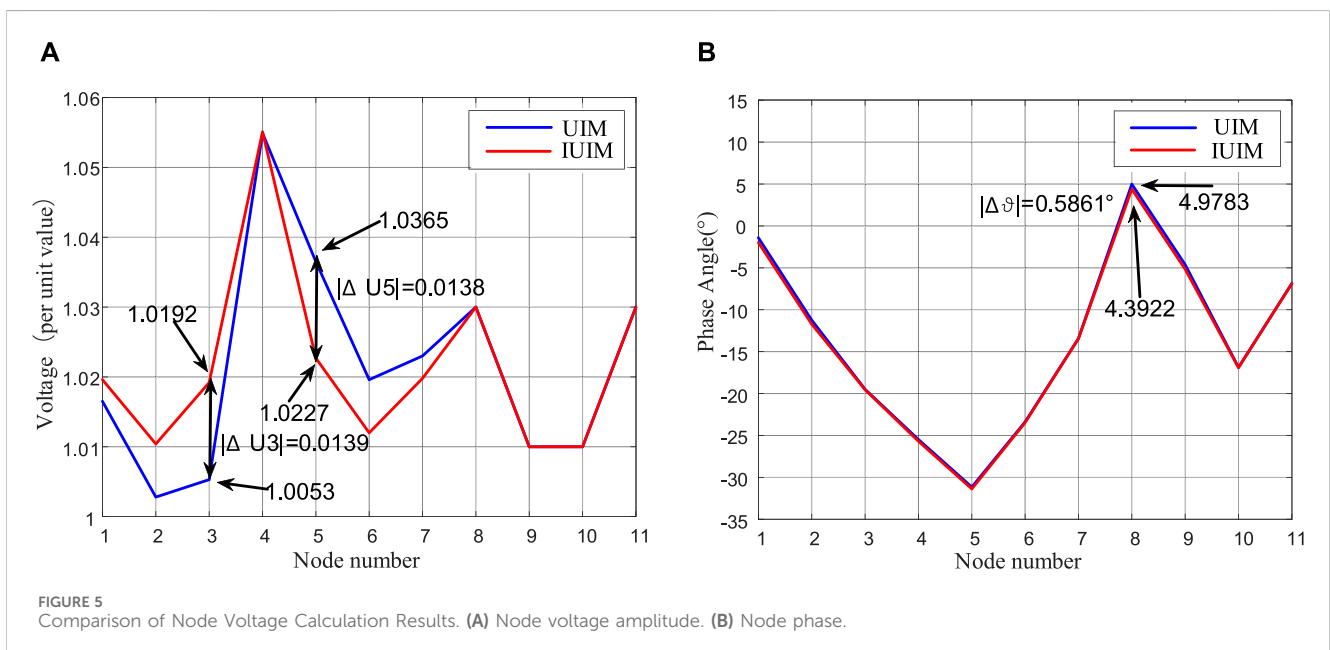
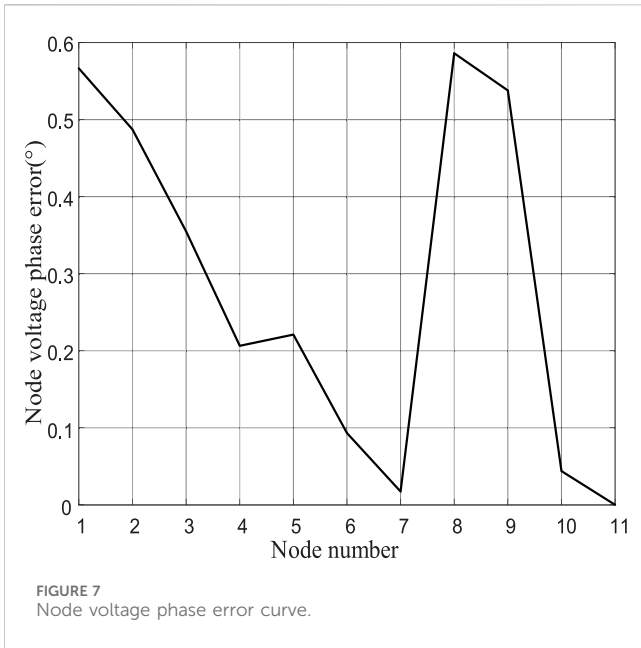

FIGURE 5 Comparison of Node Voltage Calculation Results. (A) Node voltage amplitude. (B) Node phase.



### 3 Example verification

#### 3.1 Parameter settings

The standard IEEE 11-node system is modified in this paper to form a hybrid AC/DC microgrid system, and the feasibility and computational accuracy of the proposed method are tested. The system structure is shown in Figure 2. The total number of nodes is  $n = 11$ , with  $n_a = 9$  AC nodes and  $n_d = 2$  DC nodes. Generators at nodes 8, 9, and 10 are replaced with photovoltaic sources, wind turbines, and fuel cells, treated as PV, PQ, and PV nodes, respectively. The active power output at node nine is set to  $P = 7$  (per unit value), and the voltages at nodes 8 and 10 are  $V_8 = 1.03$  and  $V_{10} = 1.01$ , respectively. Node 11 is designated as the Slack node with a voltage of  $V_{11} = 1.03 \angle -0.18^\circ$ . DC lines are added directly between nodes 3 and 5, with node 3 as the rectifier side and node 5 as the inverter side, while other lines are AC lines. The convergence accuracy is set to  $1 \times 10^{-4}$  for all calculations.

The parameters of the AC lines in the system are shown in Table 1, and the parameters of the DC lines are shown in Table 2, all represented in per unit values.

removing the variables  $\Delta Q_d$  and  $\Delta \delta_d$  from Eq. 11. The resulting correction equation is shown in Eq. 12:

$$\begin{pmatrix} \Delta P_a \\ \Delta P_d \\ \Delta Q_a \\ \Delta Z \end{pmatrix} = - \begin{pmatrix} H_{aa} & N_{aa} & N_{ad} & 0 \\ H_{da} & N_{da} & N_{dd} & A \\ M_{aa} & L_{aa} & L_{ad} & 0 \\ 0 & 0 & C & D \end{pmatrix} \begin{pmatrix} \Delta \delta_a \\ \Delta U_a/U_a \\ \Delta U_d/U_d \\ \Delta X \end{pmatrix} \quad (12)$$

Eq. 12 represents the expression of the corrected equation after improvement, which is the correction equation of the improved unified iteration method (IUIM).

#### 3.2 Results of the example

Comparing the computational results between the UIM and the proposed approach, the computation times are presented in Table 3. With the same convergence achieved in 5 iterations, the UIM has a computation time of 0.02 s, while the IUIM has a computation time of 0.004 s. With the same convergence accuracy, the computational speed has been improved, showing an 80% increase in speed.

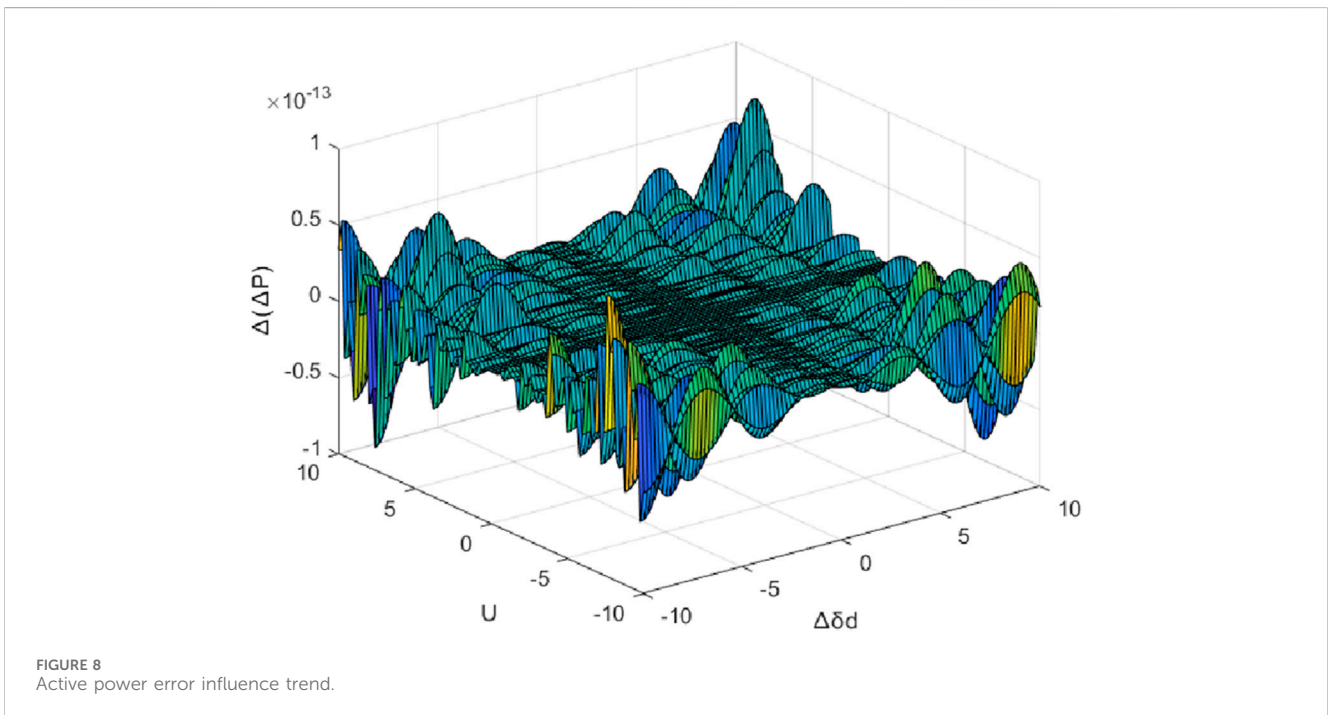

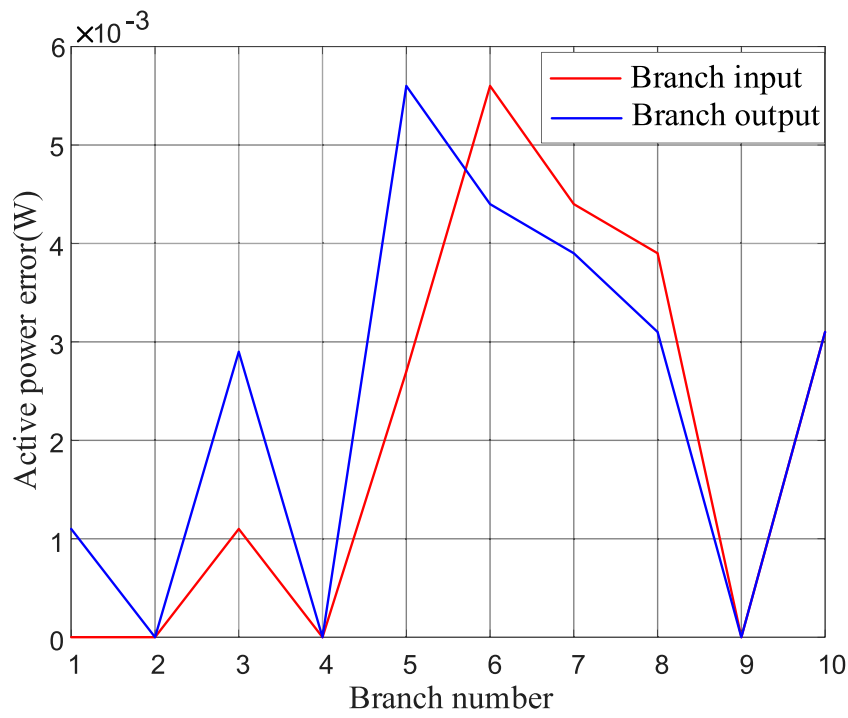

FIGURE 9 Active power error curve.

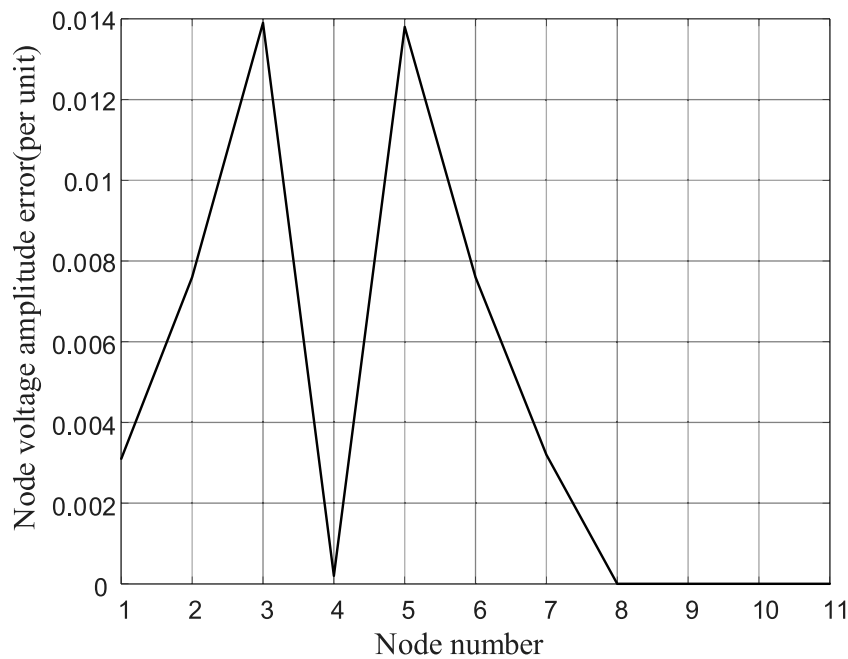

FIGURE 10 Node voltage error curve.

Comparing the injected active and reactive power of branches as shown in Figures 3A, B, the active power exhibits virtually no error. The maximum deviation for active power

input (output) of branches is  $|\Delta P_{\max}| = 0.0056$ , with an average relative error of  $\overline{|\Delta P|} = 0.00239$ . For reactive power, the maximum deviation in input is  $|\Delta Q_{in \max}| = 0.6419$ , and in

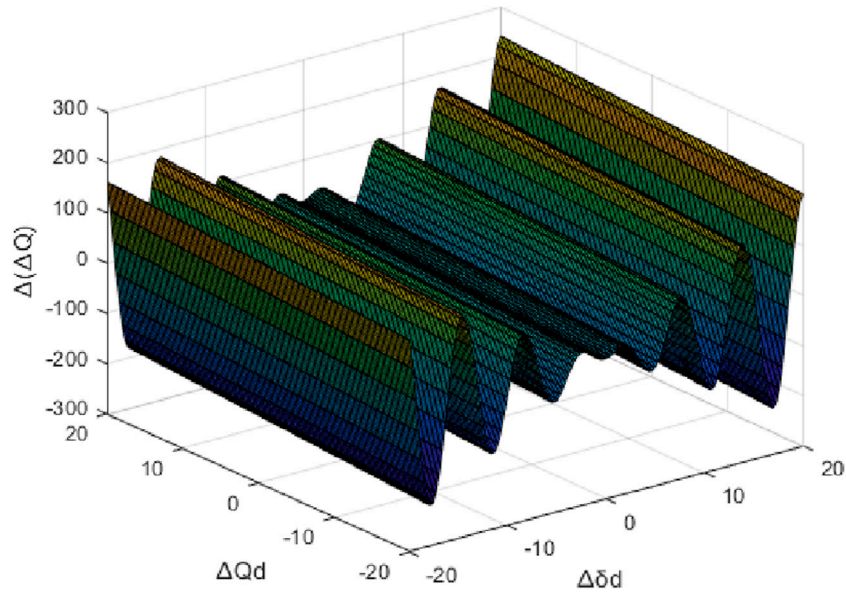

FIGURE 11  
Reactive power error influence trend.

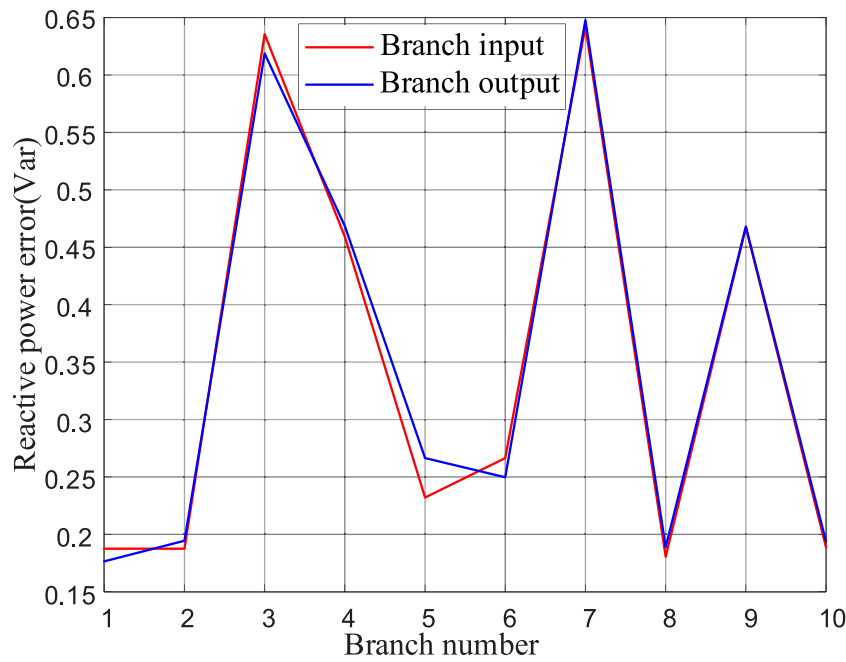

FIGURE 12  
Reactive power error curve.

output is  $|\Delta Q_{out\ max}| = 0.6478$ , with an average relative error of  $\frac{|\Delta Q|}{Q} = 0.11564$ .

Comparing the voltage transformation ratio of the DC converter as shown in Figure 4, the deviation for the DC converter ratio  $K_1$  is  $|\Delta K_1| = 0.0134$ , and for the DC converter ratio  $K_2$  is  $|\Delta K_2| = 0.012$ .

Comparing the calculated node voltage magnitudes as shown in Figure 5A, the maximum voltage deviation between the two calculations is  $|\Delta U_{max}| = 0.0139$ , with other node voltage deviations not exceeding 0.01. The average relative error in node voltage is  $\frac{|\Delta U|}{U} = 1.818 \times 10^{-5}$ . Comparing the calculated node voltage phase angles as shown in Figure 5B, the maximum phase



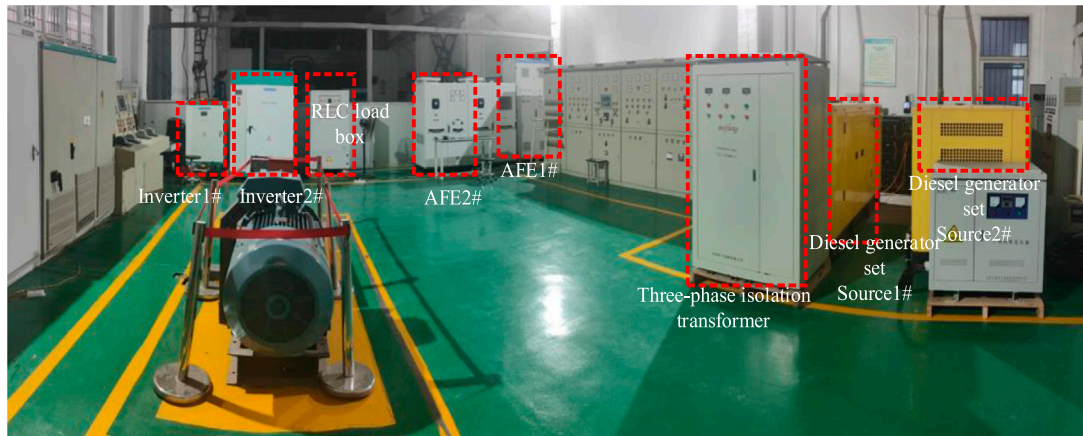

FIGURE 13 Field diagram of the experimental platform.

TABLE 4 Main parameters of the experimental platform.

Parameter	Value
Rated capacity of diesel engine	80 kW
AFE1# Rated capacity	75 kW
AFE2# Rated capacity	259 kW
Inverter 1# rated capacity	250 kW
Inverter 2# rated capacity	50 kW
Maximum capacity of the load box	200 kW
AC line impedance	1.119 + j0.964 Ω/m
DA line resistance	0.521 Ω/m

difference between the two calculations is  $|\Delta\theta_{\max}| = 0.5861^\circ$ , with an overall deviation within  $\pm 0.6^\circ$ . The average relative error in node voltage phase angles is  $|\Delta\theta| = 0.17652$ .

Based on the simulated results mentioned above, the proposed improved algorithm demonstrates a 80% increase in computational speed while maintaining small computational errors. It meets the requirements of both computational accuracy and efficiency for rapid analysis of microgrids, providing evidence for the feasibility and high computational efficiency of the proposed algorithm.

### 4 Error analysis

The power flow annotation for the modified IEEE 11-node system structure is shown in Figure 6.

From the power flow illustrated in Figure 6, it is evident that for the hybrid AC/DC system, nodes 3 and 5 involve issues regarding the synthesis and distribution of power between AC and DC systems. In this paper, certain DC parameters in the correction equations during DC power flow computation were removed, leading to relative errors between the actual values and the influx and distribution of DC power at the interface nodes between the DC and AC systems. Figure 7 shows the phase error curve of node

voltages. As the electrical distance between nodes and the reference node increases, the phase error of node voltages gradually increases. In multi-node radial networks, an increase in the electrical distance between nodes and the reference node leads to a gradual increase in calculation errors. However, for microgrid systems with lower voltage levels, where the electrical distance between nodes is shorter, the errors generated by the improved algorithm are relatively small.

Comparing Eqs 11, 12, the deviation of active power and reactive power for a single iteration process at a certain node in the system is given by Eq. 13:

$$\begin{cases} \Delta(\Delta P) = \left( \frac{\partial \Delta P_a}{\partial \delta_d} + \frac{\partial \Delta P_d}{\partial \delta_d} \right) \Delta \delta_d \\ \Delta(\Delta Q) = \Delta Q_d + \frac{\partial Q_a}{\partial \delta_d} \Delta \delta_d \end{cases} \quad (13)$$

Analyze the impact of  $U_i$  or  $U_j$  and  $\Delta \delta_d$  on  $\Delta(\Delta P)$  and conduct a quantitative analysis. It is observed that the expressions for the partial derivatives of  $\Delta P_a$  with respect to  $\Delta \delta_d$  are consistent with those for  $\Delta P_d$ . For ease of analysis,  $\partial \Delta P_a / \partial \delta_d$  and  $\partial \Delta P_d / \partial \delta_d$  are unified as  $\partial \Delta P / \partial \delta_d$ . Taking node voltage  $U_i = U_j$ ,  $G_{ij} + B_{ij} = 5 + j10$ , we plot the error influence curves of  $\Delta \delta_d$  and  $U_i$  on  $\partial \Delta P / \partial \delta_d$ , as shown in Figure 8, with all variables represented in per unit values. Combining the simulation results, the curves for active power error and node voltage error are plotted separately in Figures 9, 10.

From Figure 8, it can be observed that when  $U_i$  remains constant, at lower values of  $\Delta \delta_d$ , the numerical impact of  $\Delta \delta_d$  on  $\Delta(\Delta P)$  is relatively small. As the value of  $\Delta \delta_d$  increases, the impact on  $\Delta(\Delta P)$  gradually increases, and the degree of impact continues to grow without an upper limit. When  $\Delta \delta_d$  remains constant, at lower values of  $U_i$ , the numerical impact on  $\Delta(\Delta P)$  is relatively small. As the value of  $U_i$  increases, the impact on  $\Delta(\Delta P)$  gradually increases, reaching a maximum degree of impact. The impact curve approximately exhibits a periodic function.

At lower voltage levels,  $\Delta(\Delta P)$  is primarily influenced by  $\Delta \delta_d$ . As both  $\Delta \delta_d$  and  $U_i$  increase,  $\Delta(\Delta P)$  is influenced by both variables with similar degrees of impact. As  $\Delta \delta_d$  continues to increase,  $\Delta(\Delta P)$

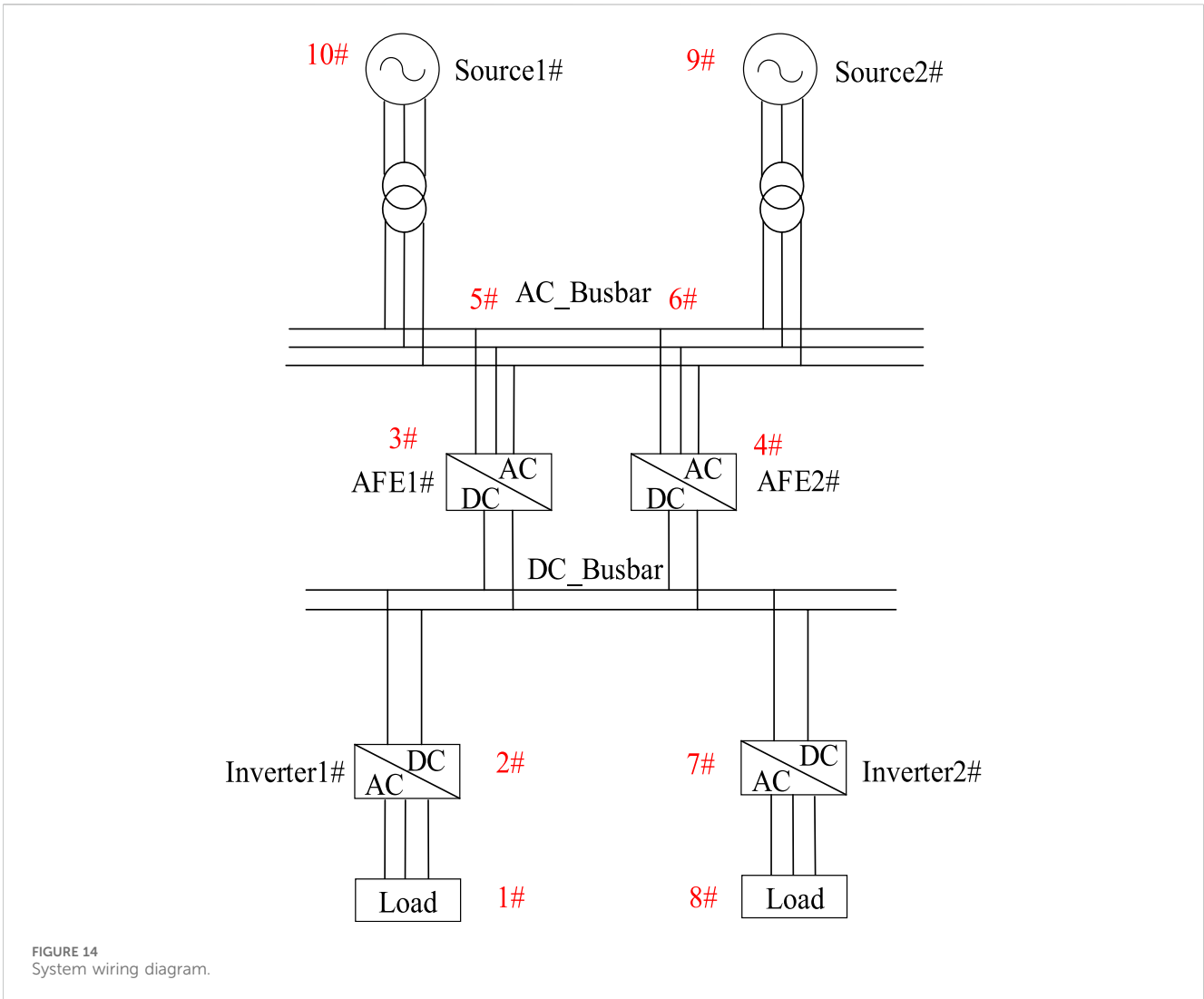

FIGURE 14 System wiring diagram.

is primarily influenced by  $U_i$ . In the example, where the voltage phase  $\Delta\delta_d$  is relatively small, the impact of  $U_i$  on  $\Delta(\Delta P)$  is more pronounced compared to  $\Delta\delta_d$ . This is evident in nodes 3, 5, and 6 where the node voltages have relatively large errors, corresponding to peaks in the active power error curve.

Analyze the impact of  $\Delta Q_d$  and  $\Delta\delta_d$  on  $\Delta(\Delta Q)$ , we plot the error influence curves of  $\Delta Q_d$  and  $\Delta\delta_d$  on  $\Delta(\Delta Q)$  in Figure 11, with all variables represented in per unit values. Combining the simulation results, the reactive power error curve is plotted in Figure 12.

When  $\Delta Q_d$  remains constant, as the value of  $\Delta\delta_d$  increases, the numerical impact on  $\Delta(\Delta Q)$  gradually increases, and the degree of impact continues to grow without an upper limit. When  $\Delta\delta_d$  remains constant,  $\Delta Q_d$  consistently has a significant impact on  $\Delta(\Delta Q)$ . Combining the power flow diagram in Figure 8, for nodes 3 and 5, there is a relationship  $\Delta Q = \Delta Q_a + \Delta Q_d$ . For lower values of  $\Delta\delta_d$ ,  $\Delta(\Delta Q)$  is primarily influenced by  $\Delta Q_d$ . As  $\Delta\delta_d$  increases,  $\Delta(\Delta Q)$  is influenced by both variables with similar degrees of impact. As  $\Delta\delta_d$  continues to increase,  $\Delta(\Delta Q)$  is primarily influenced by  $\Delta\delta_d$ , and the degree of impact becomes more significant.

Observing Figure 12, it can be noted that there are significant errors in the reactive power on branches with the branch numbers 3, 4, 7, and 9. In the example, where the voltage phase  $\Delta\delta_d$  is relatively small,  $\Delta(\Delta Q)$  is primarily influenced by  $\Delta Q_d$ . The lines with significant errors are mainly located at the connection points of DC and AC lines, specifically at nodes 3 and 5. In the iteration process, elements of  $\Delta Q_d$  in the correction equation for these two nodes were removed, leading to errors in the overall numerical values. Moreover, the closer the lines are to nodes 3 and 5, the larger the errors generated.

For systems with numerous parallel AC and DC lines in the network, the convergence and distribution of AC and DC power flows occur at the connection points. Ignoring  $\Delta Q_d$  can lead to significant errors in the iterative calculation of reactive power for the system, and the errors increase with more parallel branches. In microgrid systems with a common bus configuration, where there are fewer parallel branches, the overall error in the iterative calculation of reactive power is relatively small.

In summary,  $\Delta(\Delta P)$  is primarily influenced by the voltage phase  $\Delta\delta_d$  and voltage magnitude  $U_i$ .  $\Delta(\Delta Q)$  is mainly influenced by  $\Delta\delta_d$  and the reactive power

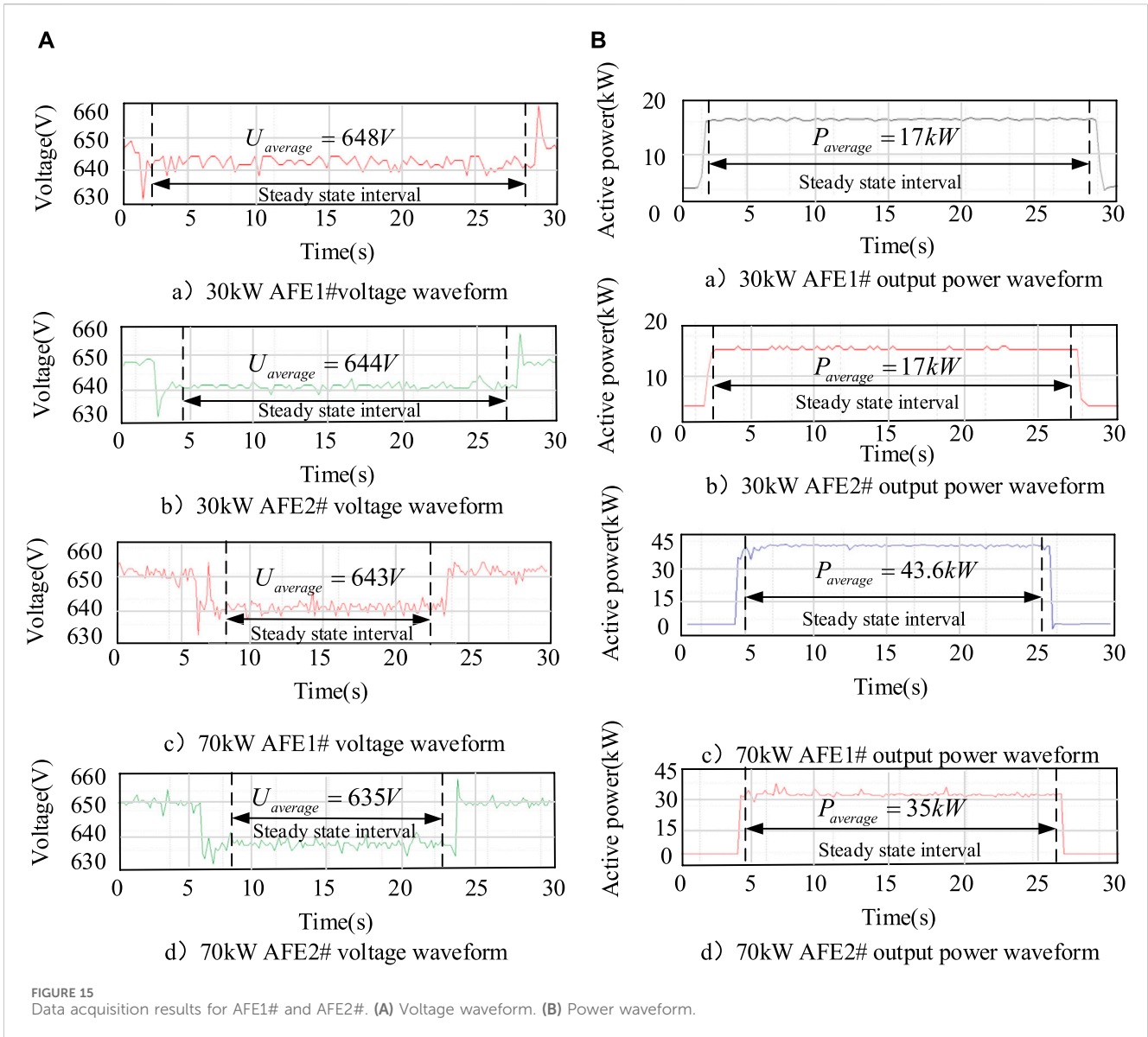

TABLE 5 Voltage calculation results and relative errors.

Node number	Voltage under 30 kW load(V)	Voltage under 30 kW load(V)	Relative error under 30 kW load (%)	Relative error under 70 kW load (%)
3	611	636	5.71	1.09
4	610	643	5.28	1.26

TABLE 6 Power calculation results and relative errors.

Node number	Power under 30 kW load (kW)	Power under 30 kW load (kW)	Relative error under 30 kW load (%)	Relative error under 70 kW load (%)
3	17.9	46	5.29	5.5
4	18.7	37.6	10	7.43

imbalance  $\Delta Q_d$ . When  $\Delta\delta_d$  is small,  $\Delta(\Delta P)$  is primarily influenced by  $U_i$ . When  $\Delta\delta_d$  and  $U_i$  are large,  $\Delta(\Delta P)$  is mainly influenced by  $\Delta\delta_d$ , and the degree of influence is significant.  $\Delta(\Delta Q)$  is primarily influenced by  $\Delta Q_d$ . At the connection points of AC and DC lines within the mixed AC/DC system, relatively large errors in  $\Delta(\Delta Q)$  and node voltage phase can occur.

## 5 Experimental verification

### 5.1 Experimental platform

To further validate the feasibility of the proposed improved algorithm, experimental verification was conducted on the experimental platform shown in Figure 13.

Table 4 shows the specific data of the experimental equipment in the experimental platform.

Equivalent the experimental platform to the system wiring diagram as shown in Figure 14, and assign node numbers to the nodes in the system. Set node 10 as the Slack node with  $V_{10} = 1.05 \angle 0^\circ$  while the remaining nodes are PQ nodes. Perform experimental validation for two operating conditions of load 1#: 30 kW and 70kW, respectively. Write improved power flow algorithm code in MATLAB, input basic data, and calculate the active power and node voltage at the (Analog Front End) AFE1# and AFE2# locations. and connect them to the upper computer. Utilize the system software to monitor the output power and voltage at these two locations, and compare the values with the calculated results.

### 5.2 Experimental result

The voltage waveforms of AFE1# and AFE2# detected by the upper computer under 30kW and 70 kW loads are shown in Figure 15A. The output power waveforms are illustrated in Figure 15B.

Utilizing the proposed improved algorithm to obtain the current power flow solution for the system, and comparing the calculated values with the steady-state values measured by the upper computer. The error results for different loads are presented in Tables 5, 6.

In summary of the above experimental results, for the 30 kW load experiment, the output power error of Node 4 is 10%, and the errors of other node variables are around 5%. For the 70 kW load experiment, the output power error of Node 4 is 7.43%, the output power error of Node 3 is 5.5%, and the voltage error is around 1%.

Comparing the error results of the two experiments, the voltage error results of AFE1# and AFE2# nodes are basically similar. AFE1# has a relatively smaller output power error compared to AFE2#. According to the error analysis results in Section 4, AFE1# is closer to the load in electrical distance, has a smaller line resistance, and requires relatively fewer iterations throughout the calculation process. Therefore, it generates a relatively smaller relative error.

Based on the experimental validation above, the error range between the overall actual measurements and calculated values is within 10%, ensuring relatively accurate results while maintaining computational speed. This verifies the feasibility of the proposed improved algorithm. Particularly in hybrid AC/DC microgrid

systems with short electrical distances, this algorithm demonstrates applicability.

## 6 Conclusion

This paper, based on the characteristics of DC systems, simplifies the correction equations of the unified iteration method and proposes a power flow calculation model for hybrid AC/DC microgrids based on the improved unified iteration method. The following conclusions can be drawn through theoretical analysis and simulation/experimental verification:

1. By neglecting the flow of reactive power within the DC system and the influence of phase angles on the system, the Jacobian matrix in the correction equations of the unified iteration method is simplified and reduced in order to derive a power flow calculation method for hybrid AC/DC microgrids based on the unified iteration method. The case results indicate that the proposed improved algorithm improves computational speed by 80% compared to the Unified Iterative Method.
2. For the proposed improved algorithm, the error in active power is mainly influenced by the voltage phase angle ( $\Delta\delta_d$ ) and voltage magnitude ( $U_i$ ), while the error in reactive power is primarily affected by  $\Delta Q_d$  and  $\Delta\delta_d$ . When  $\Delta\delta_d$  is small, the error in active power is mainly influenced by  $U_i$ , and the error in reactive power is primarily affected by  $\Delta Q_d$ .
3. To experimentally validate the proposed improved algorithm, the magnitude of errors generated for different nodes is related to the electrical distance between the nodes and the load nodes. The longer the electrical distance, the more iterations are required during the power flow calculation process, leading to larger errors.

## Data availability statement

The raw data supporting the conclusion of this article will be made available by the authors, without undue reservation.

## Author contributions

XD: Writing—original draft, Writing—review and editing. HW: Writing—review and editing. CZ: Writing—review and editing. WY: Writing—review and editing. RY: Writing—review and editing. LX: Writing—review and editing. WL: Writing—review and editing. CL: Writing—review and editing.

## Funding

The author(s) declare that financial support was received for the research, authorship, and/or publication of this article. This paper was supported by the National Natural Science Foundation of China (52171308); Natural Science Foundation of Fujian Province, China (2022J01333); Innovation Laboratory for Sciences and Technologies of Energy Materials of Fujian Province and 2022J01813.

## Conflict of interest

The authors declare that the research was conducted in the absence of any commercial or financial relationships that could be construed as a potential conflict of interest.

The author(s) declared that they were an editorial board member of Frontiers, at the time of submission. This had no impact on the peer review process and the final decision.

## References

- Bajpai, R. S. (2023). An efficient MPC-based Droop control strategy for power sharing in a hybrid AC/DC microgrid using renewable energy resources. *IETE J. Res.*, 1–15. doi:10.1080/03772063.2023.2173664
- Chen, H., Zhinong, W., and Shen, H. (2017). Three-term decoupling power flow algorithm for isolated AC-DC hybrid microgrids based on sequence components. *Electr. Power Autom. Equip.* 37 (09), 31–37+45. doi:10.16081/j.issn.1006-6047.2017.09.005
- Chen, P., Xiao, X., and Tang, S. (2019). Equivalent Algorithm of interval power flow in AC/DC hybrid distribution Network. *Proc. CSEE* 39 (04), 979–992. doi:10.13334/j.0258-8013.pcsee.180424
- Guoqing, L., Jing, B., and He, W. (2017). Review on DC grids power flow analysis and control. *High. Volt. Eng.* 43 (4), 1067–1078. doi:10.13336/j.1003-6520.hve.201700328002
- Hameed, F., Ai Hosani, M., and Zeineldin, H. H. (2019). A modified backward/forward sweep load flow method for islanded radial microgrids. *J. Technol.* 10 (1), 910–918. doi:10.1109/tsg.2017.2754551
- Heidary, J., Gheisarnejad, M., and Khooban, M. H. (2023). Stability enhancement and energy management of AC-DC microgrid based on active disturbance rejection control. *Electr. Power Syst. Res.* 217, 109105–109113. doi:10.1016/j.epsr.2022.109105
- Huang, Y., Ai, X., Fang, J., Cui, S., Zhong, R., Yao, W., et al. (2023). Holomorphic embedding power flow modeling of autonomous AC/DC hybrid microgrids. *Int. J. Electr. Power and Energy Syst.* 145, 108549. doi:10.1016/j.ijepes.2022.108549
- Ju, Y., Liu, W., Zhang, Z., and Zhang, R. (2022). Distributed three-phase power flow for AC/DC hybrid networked microgrids considering converter limiting constraints. *IEEE Trans. Smart Grid* 13, 1691–1708. doi:10.1109/tsg.2022.3140212
- Lee, J.-Oh, Kim, Y.-Su, and Moon, S.-Il (2020). Current injection power flow analysis and optimal generation dispatch for bipolar DC microgrids. *IEEE Trans. Smart Grid* 12, 1918–1928. doi:10.1109/TSG.2020.3046733
- Li, Z., Xie, X., Cheng, Z., Zhi, C., and Si, J. (2023). A novel two-stage energy management of hybrid AC/DC microgrid considering frequency security constraints. *Int. J. Electr. Power and Energy Syst.* 146, 108768. doi:10.1016/j.ijepes.2022.108768
- Lin, L., Dong, S., and Zhu, C. (2020). Power flow calculation of isolated island microgrid based on two-step solution of cofactor. *Power Grid Technol.* 44 (10), 3955–3963. doi:10.13335/j.1000-3673.pst.2019.1942
- Liu, K., Chun, W., and Wu, H. (2019b). A method for calculating linear power flow in distribution network with PV nodes. *Power Syst. Prot. Control* 47 (03), 17–22.
- Liu, K., Wang, C., and Chen, Y. J. (2019a). Linear power flow calculation of distribution networks with distributed generation. *IEEE Access* (7), 44696–44695. doi:10.1109/ACCESS.2019.2909325
- Liu, Y., Li, Z., and Fan, M. (2021). A Newton-Raphson-Based sequential power flow algorithm for hybrid AC/DC microgrids. *IEEE Trans. Industry Appl.* 58, 843–854. doi:10.1109/tia.2021.3123246
- Nejabatkhah, F., Yunwei, L., and Hao, T. (2019). Power quality control of smart hybrid AC/DC microgrids: an overview. *IEEE Access* 7, 52295–52318. doi:10.1109/access.2019.2912376
- Peng, H., Shuaihu, L., Hui, L., and Huang, X. (2017). Power Flow calculation of AC-DC hybrid microgrids operating in isolated islands. *Power Grid Technol.* 41 (09), 2887–2896. doi:10.13335/j.1000-3673.pst.2017.0379
- Pengfei, L. V. (2022). Research on HVDC operation characteristics under influence of hybrid AC/DC power grids. *Power Syst. Technol.* 46 (02), 503–510. doi:10.13335/j.1000-3673.pst.2021.2403
- Song, L., Jianwei, L., and Dong, Y. (2021). Flexible power control and voltage suppression strategy for multi-sub-microgrid AC-DC hybrid distribution system. *Electr. Power Autom. Equip.* 41 (05), 99–106. doi:10.16081/j.epae.202105030
- Song, Z., Yaohui, H., and Zhao, H. (2023). Applicability analysis of power flow calculation method for AC-DC hybrid power network with multiple types of DC [J/OL]. *Electr. Power Autom. Equip.*, 1–10. doi:10.16081/j.epae.202307004
- Wang, J., Xin, A., Wang, K., and Li, R. (2018). A new AC-DC decoupling power flow algorithm based on Augmented Jacobian Matrix. *Trans. China Electrotech. Soc.* 33 (06), 1382–1389. doi:10.19595/j.cnki.1000-6753.tces.170277
- Wang, X., Peng, C., and Sun, H. (2023). Power flow calculation for AC-DC hybrid power networks considering VSC control strategy. *Proc. CSEE* 43 (10), 3731–3742. doi:10.13334/j.0258-8013.pcsee.212339
- Yang, G. K., Dong, P., Liu, M., and Wu, H. (2021). Research on random fuzzy power flow calculation of AC/DC hybrid distribution network based on unified iterative method. *IET Renew. Power Generation* 15, 731–745. doi:10.1049/rpg2.12063
- Yang, Z. F., Xie, K. G., Yu, J., Zhong, H., Zhang, N., and Xia, Q. X. (2019). A general formulation of linear power flow models: basic theory and error analysis. *IEEE Trans. Power Syst.* 34 (2), 1315–1324. doi:10.1109/tpwrs.2018.2871182
- Zhu, L., Rong, X., Zhao, J., Zhang, H., Zhang, H., Jia, C., et al. (2022). Topology optimization of AC/DC hybrid distribution network with energy router based on power flow calculation. *Energy Rep.* 8, 1622–1638. doi:10.1016/j.egyr.2022.02.208
- Zou, Z., Wang, C., and Zhang, C. (2022). Linear power flow calculation of isolated island microgrid based on sag control. *Laboratory Res. Explor.* 41 (05), 124–129. doi:10.19927/j.cnki.syyt.2022.05.027

## Publisher's note

All claims expressed in this article are solely those of the authors and do not necessarily represent those of their affiliated organizations, or those of the publisher, the editors and the reviewers. Any product that may be evaluated in this article, or claim that may be made by its manufacturer, is not guaranteed or endorsed by the publisher.

## Nomenclature

UIM	unified iteration method
IUIM	improved unified iteration method
DPPF	Distributed Power Flow
ALADIN	Augmented Lagrangian Alternating Direction Inexact Newton
<b>Variable annotation table</b>	
Variable	Notes
$E_r$ , $E_i$	Rectifier side and inverter side AC voltage
$U_{dor}$ , $U_{doi}$	Ideal no-load DC voltage of rectifiers and inverters
$U_{dor} \cos \alpha$ , $U_{doi} \cos \beta$	The ideal no-load DC voltage of rectifier and inverter after the commutation process
$\alpha$ , $\beta$	Rectifier trigger angle and inverter extinction angle
$d_{xr}$ , $d_{xi}$	Equivalent impedance of rectifier and inverter
$U_{dr}$ , $U_{di}$	Output voltage at the terminals of rectifier and inverter
$P_{dr}$ , $P_{di}$	Terminal power of rectifier and inverter
$I_d$ , $P_d$ , $R_1$	DC line Current, active power and equivalent resistance
$\Delta P_i$ , $\Delta Q_i$	Active power and reactive power imbalance at node $i$
$P_i$ , $Q_i$	Active power and reactive power injected into node $i$
$U_i$ , $U_j$	Voltage magnitudes at nodes $i$ and $j$
$G_{ij}$ , $B_{ij}$	Real and imaginary parts of Admittance $Y_{ij}$ between nodes $i$ and $j$
$\delta_{ij}$	Phase difference between nodes $i$ and $j$
$\varphi_k$	Power factor angle of the converter
$\Delta P_d$ , $\Delta Q_d$ , $\Delta P_d$ , $\Delta Q_d$	Active power and reactive power imbalance at AC/DC flow nodes
$J$	Jacobian matrix
$K_r$ , $K_i$	Turns ratio of converter transformers on rectifier and inverter sides
$\theta_d$	Converter control angle $\omega_d = \cos \theta_d$
$\Delta(\Delta P)$ , $\Delta(\Delta Q)$	Error in active (reactive) power imbalance