

# The Role of Aesthetics, Visual and Physical Integration in Building Mounted Wind Turbines – An Alternative Approach

Dr. Tim Sharpe

*Mackintosh Environmental Architecture Research Unit, Glasgow School of Art  
Scotland, UK*

## 1. Introduction

There context for addressing energy use in the built environment includes: the climate change agenda; concerns about peak oil supply; increasing fuel costs; costs of de-carbonising grid supply; and security of supply for certain regions. All of these highlight the value and need for renewable energy supplies. The context for the increased development of renewable energy is clear. The balance of evidence coming from the scientific community concerning the threats and impacts of anthropogenic climate change is now widely accepted (IPCC 2007). This had led to an economic analysis of the actions needed to address these problems (Stern 2007), which identify the benefits of early action. In addition to the climate change agenda, other drivers in the form of concerns about peak oil supply in turn leading to scarcity and increasing fuel costs, the costs of decarbonising grid supply, and security of supply for certain regions all highlight the value and need for renewable energy supplies.

To address these problems, a range of policies and technologies are being developed to reduce consumption and to provide a greater generating capacity of low carbon and renewable energy. This requires action at a range of scales and across industries, from national generators to individual consumers.

The built environment has particular responsibilities with respect to its demand for energy and resources. The majority of the population live in urban environments and buildings account for about 50% the UK energy consumption, and housing produces 27% of CO<sub>2</sub> emissions (Boardman 2007). Furthermore, the need for a national grid to serve the built environment, which also results in transmission losses, is also a factor.

Energy consumption is based on both space and water heating, and electrical use for lighting, appliances, etc. These demands can be reduced by measures such as improved insulation and air tightness, and this is typified through approaches such as *Passivhaus* design, which aims to reduce fabric and ventilation losses to a minimum. Further reductions can be made through the use of efficient appliances and controls, but even with these measures residual electrical loads remain.

Wind energy is one of the most mature renewable technologies. The development of large scale wind farms both onshore and latterly offshore, provides a significant proportion of the UK renewable energy generation capacity. It is also one of the most visible, and thus in some quarters, contentious generators. However, the use of wind generation in urban environments has increased in scale in recent years and provides significant potential. This chapter discusses the policy drivers and approaches that are forming this market at present.

## 2. Policy

Despite an inability of the global community to reach an accord at the Copenhagen summit, many governments are committed to action to address these problems. Both the UK and Scottish Governments have identified targets to reduce both energy and carbon reduction and these are supported through both legislation and incentives. The targets identified with the UK Climate Change Act 2008 aim for an 80% reduction in carbon emissions by 2050, with interim target of 34% by 2020 (DECC 2009). The Scottish Government Climate Change (Scotland) Act 2009 has the same 2050 target, with an interim target of 42% by 2020 (Scottish Government 2009).

Many of these targets will be achieved through reductions in demand and the decarbonisation of energy supply through both carbon reducing energy generation technologies and large-scale renewable generation such as wind farms, tidal and nuclear. Nevertheless, there is considerable potential for energy production from localised, distributed, small scale systems, (generally referred to as micro generation), produced on or near buildings using a range of technologies such as photovoltaics, combined heat and power, micro-hydro and wind. An Energy Savings Trust micro generation study (Energy Saving Trust 2005) estimated that micro generation could produce up to 30-40% of electricity demand by 2050.

Small, distributed renewable generators are extremely well placed to help achieve Government targets (A.S. Bahaj, L. Myers, 2007). Early reports such as the DTI Microgeneration strategy (DTI 2005) and the Scottish Executive Energy Efficiency and Micro-Generation Bill proposal (Boyack 2005) highlighted the potential benefits of this approach, which is now included in the Climate Change legislation. The current UK coalition government have recently opened consultation on a new Micro-generation Strategy (DECC 2010), which aims to further develop this area.

The targets set in the Climate Change legislation and also associated instruments such as the UK Low Carbon Transition Plan and the UK Renewable Energy Strategy also impact on other departments, so for example, planning authorities are also required include policies in their development plans that require a percentage of the energy in new developments to come from on-site renewables (ODPM 2004)

In order to enable businesses and consumers to take steps to meet these targets, a number of schemes for assistance, in the form of advice and financial support have also been provided. These include support for advisory organisations such as the Energy Savings Trust, and the Carbon Trust and until 2010 these organisations also administered major financial incentives in the form of grants for energy saving and renewable measures, including wind turbines.

However on the 1st April 2010 Feed-in-Tariffs were introduced across the UK, which provides payments for the generation of electricity from small-scale renewables including Micro-Hydro turbines, Photovoltaics, Micro Combined Heat and Power, and Small Wind Turbines (UK Government 2010). The principle of FIT's is that the owner is paid a tariff per kWh of renewably generated energy that offsets demand on the grid. This significantly reduces the running costs and payback periods of systems, making them financially attractive to householders and building owners.

FITs cover use of Photovoltaics (PV), small scale combined heat and power (CHP), small-scale hydroelectricity and small scale wind (up to 15 kW). While all of these may be viable depending on the site location and building form, there are some key differences.

Photovoltaics are easily sited and integrated on buildings, but location, angle and orientation are very site specific, requiring good solar access and suitable weather

Technology	Scale	Tariff level p/kWh)	Tariff lifetime (years)
Solar electricity (PV)	≤4 kW (retro fit)	41.3	25
Solar electricity (PV)	≤4 kW (new build)	36.1	25
Wind	≤1.5 kW	34.5	20
Wind	>1.5 - 15 kW	26.7	20
Micro CHP	≤2kW	10.0	10
Hydroelectricity	≤15 kW	19.9	20

Table 1. Feed in Tarriffs

conditions. PV is a developing technology and although economies can be made through displacement of other building components costs such as cladding and roofing, they remain an expensive option. Although micro CHP makes efficient use of fuels, these are fossil fuels, such as gas or oil. At present systems using low carbon fuels such as biomass are either very expensive, or not available at a sufficiently small scale. Micro-hydro is very site specific and very uncommon in urban environments.

Of these wind is the most mature. However wind systems have tended to be in rural situations, and the emerging question is whether wind can be a viable and cost effective means of generating electricity on or near buildings. FIT's makes the economics of wind turbines more attractive in general, and provided turbines are well sited, they can give good power outputs and payback periods, but the potential confounding factors become more complex when considering turbines in urban environments.

### 3. Urban wind systems

Over the past 20 years there have been major advances in the technology and efficiency of large-scale wind turbines. The relatively recent use of small turbines in urban areas has remained peripheral to the mainstream wind energy industry and remains an under researched area.

However, use of this type of installation has increased in recent years, due to increasing interest in renewables amongst building owners, users and designers, combined with stimulus from grant aid. The introduction of FITs is likely to further increase demand.

There are some potential advantages to mounting turbines on buildings. The energy generated is renewable, zero carbon and localised, and can contribute to carbon reduction and micro generation strategies. It can be utilised directly by the building, and will be eligible for FIT's, making it a more economically attractive option. It also raises the profile of energy generation and use and there is some evidence that this can help to raise awareness of consumption among building users.

There are also possible benefits to be derived from the theoretical augmentation of wind flow around buildings, (Mertens, 2002 and 2003) and this research has been developed in relation to building forms (Taylor 2998) (Steemers et al 1996), (Lu and Ip 2007). This has also led to research into the use of ducted wind systems on buildings (Dannecker & Grant 2002), (Watson et al 2007).

As a result of these factors the small wind (>15kW) market has achieved major expansion over the past 5 years with generating capacity increasing from 2.47 GWh in 2005 to 35.8 GWh in 2009, resulting in carbon savings of 1558t in 2005 to 22,000t in 2009 (Renewable UK, 2010).

Several areas of growth within this are noted. Firstly, the majority of installed turbines are freestanding with a cumulative total of 11483 machines installed in 2009. However, the

number of building mounted turbines has increased from 2 in 2005, to a total of 2432 in 2009. The vast majority of turbine systems are Horizontal Axis (HAWT) turbines (97% in 2009), but in recent years there have been an increasing number of Vertical Axis (VAWT) turbines emerging on the market.

At present there are over 20 UK and many more overseas companies active in the UK market. In 2009 there were over 3280 different turbine types rising from only 1163 in 2005. Overall the picture of the small wind market is that is steadily increasing and all the indications are that the introduction of FITs will provide a significant boost. Indications are that the number of grid-connected systems will increase.

Although the indications are that the number of building mounted system may increase, the projected percentage increase is not great and it is apparent that this type of application is at something of a crossroads. Difficulties have been encountered with building mounted systems and the Warwick Wind Trials in 2009 (Encraft 2009) examined the operation of 26 building mounted wind turbines from five manufacturers across the UK during 2007-2008. These turbines were mounted on sites ranging from theoretically poor (single storey urban buildings) through to theoretically excellent (45m tall exposed flats in isolated settings on hilltops).

The study found wide discrepancies in performance and output from the varying turbines and sites, and only those system on tall buildings produced useful amounts of energy. Predictions of power generation, particularly on low-rise sites were very inaccurate, due in part to poor predictions of wind speeds, but also inaccurate power curves from some manufacturers. Despite attempts to improve this by tools such as  $\mu$ -Wind (Bahai et al 2007), subsequent research has shown that performance remains highly site-specific (Peacock et. Al 2008).

Thus while there is a potential market for building mounted machines there is increasing evidence that mounting turbines on to or near buildings has been detrimental to performance (Carbon Trust 2008) resulting in relatively poor cost-effectiveness (Mithraratne, 2009). The possible exception to this is turbines mounted on tall buildings, which have been demonstrated to have greater effectiveness (Phillips et al 2007).

#### **4. Technical barriers**

Mounting turbines onto buildings presents a number of technical and aesthetic challenges. The additional cost of installation is also proving to be a significant barrier to building mounted systems (Sharpe 2008). Most systems require a bespoke adaption to a generic ground fixing system and this requires additional design and fabrication as well as statutory permissions such as planning permission and building warrant. Furthermore, the costs of installation and later maintenance, for example crane hire, road closure and costs associated with working at height, particularly on high or exposed parts of buildings, compromise their cost-effectiveness.

As well as the principle issues of performance, several other issues arise when considering building integrated systems:

##### **4.1 Structure and construction**

The structure of the building needs to provide sufficient lateral stability due to increased wind loading, and be able to accommodate fixing points for the turbine itself. These will be

at the highest points of the building, typically at gable ends and eaves on smaller buildings and at roof level on multi-story buildings. While the additional lateral loads to the building as a whole are not likely to be large, the point loads produced by the fixings may be substantial, and this can be problematic for smaller buildings with weaker structures. Larger turbines may also require an additional bespoke fixing system, depending on the nature of the underlying construction, size of turbine and method of assembly and maintenance.

#### **4.2 Installation**

Free-standing turbines incorporate a simple base fixing system, generally a concrete pad and can be assembled at ground level. For building mounted systems, fixing has to be at height and this can require the use of machinery for lifting, increasing cost and complexity. This is particularly the case for tall buildings, which will require a crane.

#### **4.3 Maintenance**

There is need for safe access for maintenance of the turbines. This is typically an annual inspection. For smaller buildings this may be possible by ladder access, or cherry picker but for larger turbines on taller buildings, the roof space must enable access and some arrangement is required to access to the generator and blades. A common method is a hinged base to allow the turbines to be tilted flat. The orientation and mechanism for this requires further consideration in relation to the roof design. Flat roofs make this straightforward, but more detailed consideration would be required for sloping and curved roof forms.

#### **4.4 Service requirements**

In order to be effective the provision should make the best possible use of existing service provision. Minimal additional requirements would include an inverter and associated switchgear will require space within the building.

#### **4.5 Safety**

Safety is a primary concern with the use of turbines in urban, populated environments. There are four main identified concerns: failure of the turbine or fixings leading to collapse, proximity to people; blade shedding; ice formation and shedding. While there have been no recorded incidents of these problems, the installed base is small and the need to evaluate and undertake risk assessment contributes to the complexity and cost of the installation.

#### **4.6 Environmental Impact**

Noise and vibration are major concerns associated with turbines. Smaller turbines are quieter and generally do not require gearing mechanisms as the rotor is coupled directly to the generator, which is the main source of noise. In addition the ambient noise in urban contexts also provides some masking of turbine noise. In general noise has not been found to be a major issue, however there are some examples where complaints by residents have led to turbines being removed.

The risk of vibration may be present if transmitted directly to the structure and this may require the use of damped bearings. Other environmental concerns include visual flickering, radio, TV and telephone interference, aircraft safety, and bat and bird life.

## 5. Aesthetic barriers

When considering the use of turbines in the urban environment, their appearance becomes a key issue. Consideration would include the appearance from a distance, shadow casting (especially of moving blades), integration with building form and the actual turbine design. Whilst technical issues can be investigated and solved, the question of appearance and visual integration is harder to address. The majority of turbines are unmodified HAWT systems, designed from a cost and utilitarian standpoint and these have not been designed to be integrated visually with buildings. The majority of installations consist of a conventional turbine, mounted on a mast, which is fixed to the host building.

However there have been systems coming onto the market that have been developed specifically for the urban environment in which their appearance is an important factor. This has resulted in several commercially available turbines that are marketed for the built environment as evidenced in their product literature, for example, Swift "is the first quiet rooftop wind turbine" ([www.swiftwindturbine.com](http://www.swiftwindturbine.com)). Of particular interest is the development of VAWT systems for building integration such the Quiet Revolution produced by XCO2 "designed in response to increasing demand for wind turbines that work well in the urban environment" ([www.quietrevolution.co.uk](http://www.quietrevolution.co.uk)), and Turby "especially designed for use in the built-up environment (urban areas) on the rooftop of high buildings" ([www.turby.nl](http://www.turby.nl)). VAWT turbines have the advantage they do not need to rotate to face wind direction, and are visually more suited to being building mounted, but in general are not as efficient as HAWT installations.

A critical issue in regard to building integrated turbines is the impact that appearance and integration can have on planning consents. Until recently, the relative novelty of building integrated turbines meant that planning departments had difficulty dealing with such applications, and this led in many cases to delays, requests for further information, or problematic conditions, for example, mounting turbines below the roofline.

In England and Scotland, changes to permitted development rights for renewable technologies introduced on 6th April 2008 and 12th March 2009 respectively, have lifted the requirements for planning permission for most domestic microgeneration technologies, however this legislation does not yet extend to small wind.

Accordingly small wind energy installations still require planning permission and local consultation with relevant stakeholders, such as neighbours. Deciding factors include environmental considerations, access to the site, noise and visual effect. Overall, national planning policies support the development of small-scale wind energy, and the introduction of Planning Policy Statement 22 (PPS22), (ODPM 2004), sets out a clear national policy framework on renewable energy for planning authorities to ensure that the Government's renewable energy targets are met. Under PPS22 regional and Local Planning Authorities should recognise the full range of renewable energy sources, their differing characteristics, locational requirements and the potential for exploiting them subject to appropriate environmental safeguards. PPS22 introduces a new policy area for small systems by encouraging Local Planning Authorities to require that new developments should supply a percentage of their energy needs from onsite renewable energy sources.

Similar proposals exist in Scotland with the Planning Advice Note 45 'Planning for Micro Renewables' and at present there is a consultation on permitted development rights for microgeneration equipment on non-domestic properties. This consultation invites views on what the thresholds might be for microgeneration equipment on non-domestic properties.

Introducing the proposals would remove the need for a planning application to be submitted for the equipment falling within the thresholds.

Although this guidance may assist the planning process, the issue of visual integration remains a critical issue in respect of building owners and occupiers.

## **6. Architectural Integration**

It is a fundamental tenet of architectural design that the form and appearance of the building is critical. Issues of context, site and materials are used within the design process to determine an architectural approach to a particular building and place. The ability of renewable systems to be effective visually integrated within a design concept is therefore a critical concern. A distinction may be drawn here between installations on new and existing buildings, which can have very different approaches.

### **6.1 New buildings**

With new buildings, the ability to make the building energy efficient through its fabric performance, form, orientation and mechanical systems provides the greatest scope for energy and carbon reduction. However, in most cases residual energy demands, particularly electricity remain and this demand can potentially be met through building integrated renewable energy generation. With a new building design, the capacity to incorporate turbines into the overall building form is greater. An early demonstration of this concept was the ProjectWEB project (Campbell & Stankovic 2001), and whilst several building concepts incorporating integrated turbines have been publicised, for example Bill Dunsters Flower Tower (<http://www.zedhomes.com/html/about/options/skyzed/>) and more recently the Dynamic Revolutions project ([www.dynamicarchitecture.net](http://www.dynamicarchitecture.net)), It is only relatively recently that this approach has now been realised with high profile buildings such as the Bahrain World Trade Centre ([www.bahrainwtc.com](http://www.bahrainwtc.com)), and in the UK the Strata development ([www.stratalondon.com](http://www.stratalondon.com)).

The difficulty with this approach is that it requires a particular building form to concentrate air flow and accommodate the turbine system, both of which will compromise the plan and plot ratio of the building. These issues may not be critical for one-off, high specification landmark buildings, but it does limit their potential replicability. Approaches such as Strata in which the installation is at roof level minimise this, but nevertheless, such bespoke arrangements will necessarily be expensive.

The other key question is how efficient these turbines are in practice in terms of power output, and environmental impacts such as noise and vibration, but to date there is not sufficient results from these projects. This type of installation requires one-off turbine systems, which will be expensive, and accurate predictions of power curves and outputs will be difficult to calculate. Cost effectiveness will also be limited, although this is likely to be a secondary consideration for these types of development.

### **6.2 Existing buildings**

The use of wind turbines on existing buildings is perhaps a more important consideration. To return to the context for a moment, it is estimated that up to 87% of the homes that will exist in 2050 have already been built, (Boardman 2007) and 85% of this was built before 1985 (Gaterell & Mcevoy 2005).

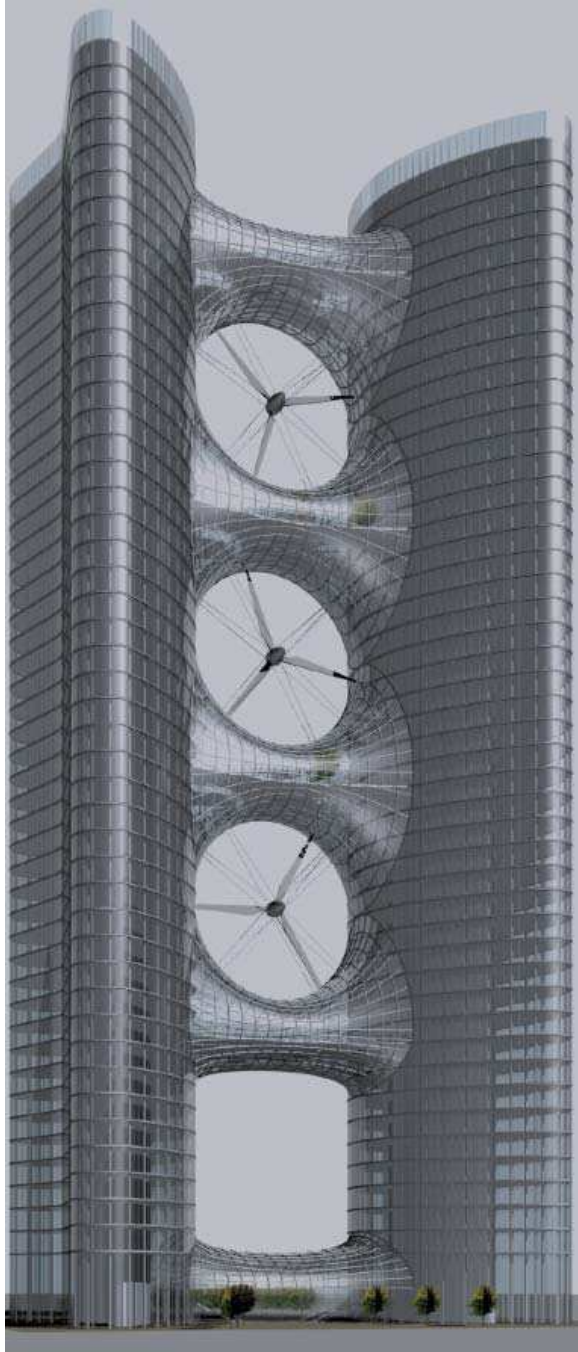

Fig. 1. Project Web: Wind Energy For The Built Environment proposal





Fig. 2. SkyZED proposal



Fig. 3. Dynamic Architecture



Fig. 4. The Strata Building, London.



Fig. 5. Bahrain World Trade Centre

As existing buildings were built to lower standards and are far less thermally efficient, their carbon production is far more problematic. At the same time, reductions in demand through refurbishment are technically harder to achieve due to existing construction and materials and accordingly are more expensive. Retrofit of insulation cannot generally meet the standards of new construction, and the existing layout will also tend to compromise other energy saving measures.

For existing buildings then, even with improvements in performance, residual electrical loads are likely to be higher. This can increase the attractiveness of renewable generation in terms of carbon reductions, but at the same time limitations through the building form,

orientation, exposure and construction compromises the type size, placement and utilisation of the systems.

In situations where turbines have been installed on existing buildings, the prevalent condition is the use of an existing turbine system, which has been mounted on the building, generally at roof level. The majority of monitored data has come from this type of installation, and as indicated in the Warwick Wind trials, the overall performance has been disappointing.



Fig. 6. Roof mounted turbine

Well-sited turbines can be effective, but the additional installation and maintenance costs undermine their overall economic viability. Although it can be demonstrated that there are economies of scale that can improve pay-back, the most effective technique for improving output - use of larger turbines - is not visually or technically feasible on buildings. There are four reasons for this.

1. Large turbines would generate significant loads on the host building. These are generally not problems of the lateral stability of the building itself, but more localised loads onto the connection points.
2. The ability to access the turbine for maintenance or repair would be difficult and expensive.
3. Potential environmental factors such as noise and vibration may become more apparent, especially when the generator becomes large enough to require a gearing mechanism.
4. The relationship of the size of the turbine to the building itself. Although larger buildings could accommodate larger turbines, the overall proportion would limit what was visually acceptable.

In the case of existing buildings, there is very little scope for the form of the building to be adapted to aid integration. Alterations to the building form will be technically difficult and therefore expensive. The primary mechanism therefore to improve appearance resides with the turbine design itself, and appears to be a viable tool in the marketing and implementation of urban turbines. It is interesting that promotion of these types of systems

has primarily been through their aesthetic performance, rather than any direct benefit of being building mounted.

Thus there exists a dichotomy with regards to visual appearance of turbines on buildings. On the one hand, improved appearance and integration can improve the attractiveness of this option, leading to a greater installed capacity. On the other hand, there is a danger that this type of installation may be used as a visual signifier of sustainability, and if these installations do not perform well, the market may become undermined.

The fact that the popularity of some turbine forms is not based solely on their generating capacity illustrates the value placed on the appearance of devices that will be visible to the public. While attractive appearance may be a useful driver to adoption of this technology, there is some inherent risk in this if the rationale is driven by public profile, rather than a realistic assessment of energy production. The term 'eco-bling' has been used to describe ostensible, but ineffectual devices by Professor Doug King, and this is evidenced to some extent by the developer of the Strata project: "The brief we gave to Hamilton's Architects was we wanted a statement, we wanted to create benchmarks for sustainability and urban living. We wanted something bold, we wanted remarkable." (Black 2010)

The evidence presented so far would lead to the conclusion that small wind is generally not viable in urban situations, but this may not be a true picture. Firstly, it is apparent that many turbines are not well sited, either in terms of geographical location, or placement on the building. This is hampered by difficulties in accurate prediction of performance, both through reliable manufacturers data, and predictions of wind at particular sites. Many efficient systems are not visually attractive and are difficult to visually integrate onto buildings.

However, in situations where efficient turbines have been well sited, marked improvements in performance are recorded (ENCRAFT 2009), and certain building forms, such as high-rise buildings can deliver good performance.

In summary, whilst there are policy and economic drivers leading to an increasing demand for urban turbines, the current state of the art has not produced an effective building integrated turbine. At present it seems unlikely that a solution will emerge from a conventional HAWT, which in general are designed for mast mounting in unobstructed areas. In considering the shortfalls of existing systems, the following desirable characteristics emerge:

- Building integrated for visual performance.
- Building integrated for augmented flow.
- Scalable and economic.
- Good power output in turbulent and gusting sites.
- Ease of installation.
- Applicable in a wide variety of locations.

## 7. Crossflex

To address these issues an concept originally developed by Proven Energy and further developed by MEARU, proposes an alternative turbine for use in the urban environment. 'Crossflex' is based on a Darrieus turbine, but includes a number of innovations to improve its performance and applicability in the built environment.

Crossflex takes the basic Darrieus form but mounts it within a frame with the shaft held at either end. The blades incorporate low solidity and low mass materials, which being flexible, can assume a natural troposkein shape at speed, Control of rotor speed and

overspeed protection is proposed by means of passive twisting of the blades. The design concept is a system that is modular rather than scalable. Based on a 1kW unit, increased capacity is derived from a greater number of units (Sharpe & Proven, 2010).



Fig. 7. Crossflex concept

The research to date has examined a number of issues related to the theoretical performance, particularly those relating to the blade design. Work has also been undertaken on the potential for building integration.

### 7.1 Technical innovations

The critical design issues include the variable twist aerofoil sections, the pitch control mechanism, aeroelastic stability issues and noise and vibration control. These have been examined using a theoretical model developed from the multiple streamtube momentum balance approach first developed by Strickland (Strickland 1975) and later improved by Paraschivoiu (Paraschivoiu 2002) for more specific purposes such as analysing self starting capabilities, assessing toe-in/ toe-out angles, factoring for downwind losses and crucially, investigating the potential for passive over speed control via blade pitch control. Analysis has been based on a turbine with the following specifications: Rotor height = 2.73 m, radius = 2.436 m, chord = 0.07 m, blade length = 3.55 m, blades = 3, swept area = 4.44 m<sup>2</sup>). The provisional power curve is shown in Fig. 8.

Several configurations of blade cross-section are under consideration. As very little bending is experienced, there is greater scope for use of anisotropic materials, or composites to provide the section shape, with various configurations of ropes or wires providing the principal tensile strength.

Small toe-in and toe-out angles are required to smooth the torque peaks of the upwind and downwind sections. However the variation of toe-in and toe-out angles with wind speed are roughly linear, so could be configured with a spring to gradually increase the magnitude of the negative pitch angle with increasing rpm (via centrifugal force).

Consideration of the rotational speed of the rotor is also required. Limiting the rotor rpm is important when considering the generator coupled to the rotor shaft, as most generators operate most effectively within a fairly narrow ratio of maximum to minimum rpm, usually about 4-to-1.

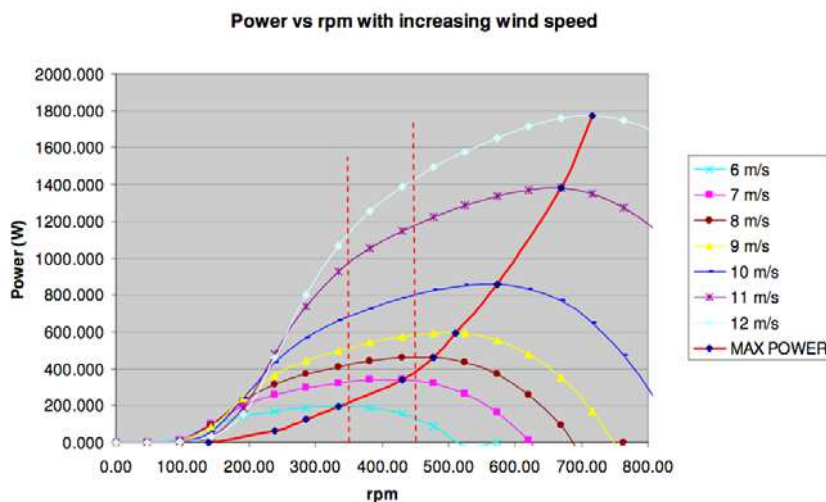

Fig. 8. Power vs rpm with increasing wind speed

Most turbines operate at fixed rotational speeds except when starting and stopping and this is beneficial when using synchronous generators in parallel with the utility grid. However, this means that the maximum coefficient of performance  $C_{pm}$  is available only at one particular wind speed. A lower coefficient of performance is observed for all other wind speeds, which reduces the energy output below that which might be expected from variable speed operation.

This indicates that if fixed speed operation is required, then 450 rpm is a good choice of operating rpm for sites with a high percentage of winds between 6 and 10 m/s since the turbine can deliver nearly the maximum possible shaft power over this wind speed range.

Analysis of the turbine torque versus the load torque indicates that a variable speed turbine is technically possible. There is a possibility of simplified construction and lower costs and also a possibility of greater energy production from a given rotor. Fixed speed systems will probably dominate where induction or synchronous generators are used to supply power to the grid, but variable speed systems may find a role in stand-alone situations.

Although a generator with a suitable load characteristic can limit the rotor speed, a further limiting device is required should the generator either fail or provide insufficient counter torque in gusty conditions. Ideally this other speed limiting device will take the form of a passive mechanism which induces a pitch change at a specific rpm and so drastically reduces the aerodynamic performance of the blades in order to limit the rotor torque above that rpm. Possible models being examined include twisting of the blade, either through feathering or stalling. This will depend on the blade material and construction, and also the nature of the fixing at the blade root. The use of dampers at these points, either at one end or both ends, seems the most promising approach.

The power density based on the streamtube analysis is promising, indicating a power output of up to 1kW and a power density 0.196 kW/m<sup>2</sup>. However this analysis does not take into account induced velocities. Allowing for this but also modifying the toe-out angle indicated a figure of 0.79kW, but work on ducted and augmented systems suggests that additional enhancements are possible through the form of the cowling.

### 7.2 Visual integration

This form has several advantages with regard to building integration and may help to overcome a number of the problems that existing systems have encountered. The shaft is supported at either end and therefore is in simple bending, as opposed to a cantilever in a conventional Darrieus system, and so the loads on the fixings, shaft and bearings are distributed significantly reduced and smaller, lighter elements can be used.

The cowling also provides a much greater range of potential fixing points to the host structure. Not only does this distribute the loads imposed onto the host structure, it also enables a degree of adaption to varying underlying forms. Thus fixing points can be positioned, within certain limits, to suit the structural system of the host structure. This is a critical aspect in relation to the application to existing buildings, in which the structure is varied, and generally cannot be altered. For example, a building with steel trusses at 2400mm centres section may only require four fixing points on two trusses, but one with weaker timber trusses at 600mm centres may accommodate up to ten fixings over five trusses.

The shape of the cowl has the potential to augment and concentrate airflow over the blades. One of the variable factors in the urban environment is the presence of turbulent airflows and vortex shedding around buildings. As buildings are not generally designed to accommodate this, some adaption is necessary to help smooth airflow into the turbine path, and the benefits of this have been identified in previous work (Aguilo et al 2004), (Wang et al 2008)

The cowl will also be the main visual element of the system and the choice of material, colour and texture can be varied to suit the host structure. This has the advantage that the host structure does not require any adaption to aid physical or visual integration.

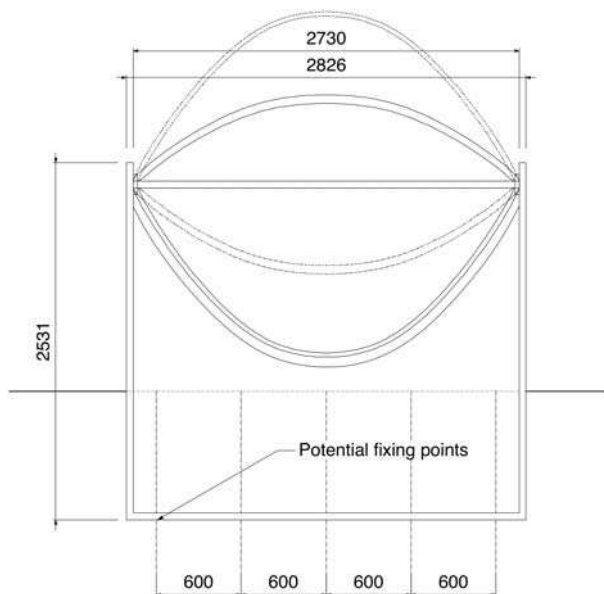

Fig. 9. Overall dimensions and fixing points



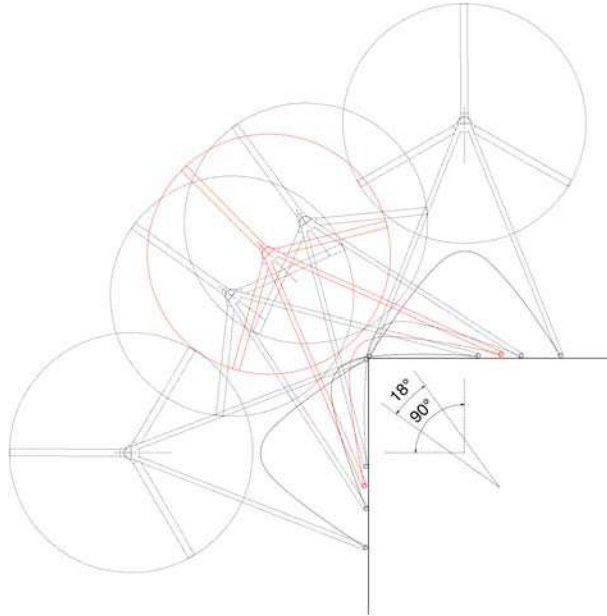

Fig. 10. Geometric arrangements for locations.



Fig. 11. Horizontal Arrangement





Fig. 12. Vertical Arrangement



Fig. 13. Pitched roof mounting.

There are a number of possible materials that may be used to form the cowl, the most obvious being composite materials such as glass or carbon reinforced plastics. This may provide the opportunity for the cowl to act as a monocoque structure. However, the localised loads at the shaft connection may be difficult to accommodate, and issues of vibration would need to be analysed.

The alternative strategy would be to provide a steel structural frame, with a very lightweight skin. The required shape of the cowl naturally produces an anticlastic form and this allows the use fabrics and films. As well as being very lightweight, these can also

potentially provide some degree of transparency to reduce its visual impact and aid visual integration, as well as being easily replaceable.

A key aspect of the proposal is that of modularity. As previously discussed, conventional turbine development has attempted to provide efficiency and capacity through increased scale. In the built environment market there are limitations to the size of turbine that can be accommodated both technically in terms of loads, and visually in terms of scale and integration.

The intention behind Crossflex is to produce a relatively small, but potentially modular device. Keeping the turbine small helps to minimise and distribute structural loads, reduces vibration to the host structure, and reduces the scale of plant required for installation.

A modular system can use a larger number of units to increase capacity. This is an especially important characteristic in relation to corner and edge mounting on tall buildings whereby installation capacity is significantly greater. This can be illustrated in Fig. 14, which shows a comparison of the visual impact of a 6kW VAWT turbine with 6 Crossflex turbines on the Newbery Tower, a campus building at GSA.

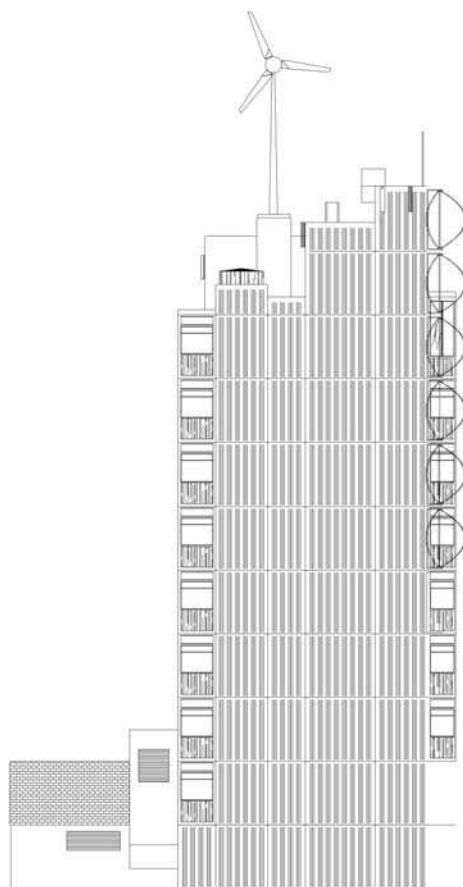

Fig. 14. 6kW Proven VAWT vs 6 No 1Kw Crossflex

The use of Crossflex provides a far more disbursed model and there are also fewer localised structural point loads. Although there are a larger number of fixings, these will be taking much smaller loads, so can more rapidly installed bolt or anchor systems. In this example, installed capacity could be between a factor of 4 or 6 times greater if all possible mounting locations where used.

Modularity also leads to economies of scale derived from reduced manufacturing costs and generic fixing and installation systems. It enables interchangeable components for maintenance or change in appearance (for example material or colour or the cowl). Conventional building mounted installations have significant installation costs and technical difficulties, for example structural loads, and installing a larger number of units need not necessarily increase these. Indeed modularity can also assist with the feasibility of installation if components can be kept small enough to be easily handled and assembled in-situ with the minimum of plant.

## 7. Conclusion

Although there is both an existing market and further potential for small wind generation in the built environment, experience to date has shown that there are considerable challenges in exploiting this potential.

Although well-sited, efficient and well-integrated turbines can make a valuable contribution, there has been a rush to market of conventional machines that are not designed for use in urban environments. This has led to situations where performance is poor.

The fact that turbines are a very visible manifestation of renewable technology on buildings presents some conflicting challenges. Conventional turbines can be unattractive and this can lead to problems of planning, and acceptability by building users and designers. However, addressing this issue can then lead to systems which are less efficient, or that are used inappropriately.

The built environment is more complex than rural installations, with a number of compound interactions involving clients, specifiers, designers, the public, legislative and statutory bodies, as well as technical issues such as turbulence, installation, safety and environmental impacts. It is therefore critical that devices for this market need to be designed with these factors in mind. Urban turbines do have the potential to contribute to carbon savings, provided they can utilise design features that make them economically viable.

Given the diversity of the urban environment, it is unlikely that a single form will become dominant. There are major differences in applications between bespoke turbines for new-build developments and manufactured systems for existing buildings. This suggests a number of niche markets are possible, but whether these are of sufficient scale to justify commercial development is unclear, but does indicate a role for further research.

## 8. Acknowledgements

Fig. 2. Kind permission of The Zedfactory Ltd

Fig. 3. Kind permission of Dynamic Architecture

Fig. 4 Kind permission Brookfield

Fig. 5 Kind permission Atkins

## 9. References

- Aguilo, A.; Taylor, D.; Quinn, A.; Wiltshire, R. (2004). Computational Fluid Dynamic Modelling of wind speed enhancement through a building augmented wind concentration system, European Wind Energy Conference 2004
- Bahaj, A.S.; Myers, L. (2007). Urban energy generation: Influence of micro-wind turbine output on electricity consumption in buildings, P.A.B. James, Energy and Buildings 39 2007 154–165
- BERR (2010). Microgeneration Strategy consultation  
[www.decc.gov.uk/en/content/cms/consultations/microgen\\_strat/microgen\\_strat.aspx](http://www.decc.gov.uk/en/content/cms/consultations/microgen_strat/microgen_strat.aspx)
- Black, (2010). London landmark building will generate 8% of its energy needs, The Guardian, Sunday 14 March 2010  
[www.guardian.co.uk/environment/2010/mar/14/razor-tower-wind-turbines?intcmp=239](http://www.guardian.co.uk/environment/2010/mar/14/razor-tower-wind-turbines?intcmp=239)
- Boardman, B. (2007). Home Truths: A low Carbon Strategy to reduce UK Housing emissions by 80% by 2050.  
<http://www.eci.ox.ac.uk/research/energy/downloads/boardman07-hometruths.pdf> University of Oxford ISBN 1 874370 43 5
- Boyack, (2005). The Energy Efficiency and Micro-Generation Bill Proposal (2005  
<http://www.scottish.parliament.uk/business/bills/pdfs/mbconsultations/microgeneration.pdf>
- Carbon Trust, (2008). Small scale wind energy - Policy insights and practical guidance (CTC738),  
<http://www.carbontrust.co.uk/Publications/pages/PublicationDetail.aspx?id=CTC738>
- Campbell, N.S.; Stankovic, S. (2001) Wind energy for the Built environment – Project WEB. A report for Joule III Contract No JOR3-CT98-01270 2001
- Dannecker, R.K.W.; Grant, A.D. (2002) Investigations of a building-integrated ducted wind turbine module, Wind Energy Vol 5 No 1 pp 53-71 2002
- DTI (2005). DTI, Potential for Microgeneration: Study and Analysis, Department of Trade and Industry, November 2005, <<http://www.berr.gov.uk/files/file27576.pdf>
- Encraft (2009). Warwick Wind Trials Project. <http://www.warwickwindtrials.org.uk/2.html>
- Energy Savings Trust (2007). Generating the Future: An analysis of policy interventions to achieve widespread micro generation penetration.  
<http://www.energysavingtrust.org.uk/>
- Gaterell,; McEvoy (2005), The impact of climate change uncertainties on the performance of energy efficiency measures applied to dwellings, Energy and Buildings Volume 37, Issue 9
- Lu, L.; Ip, K.Y. (2007). Investigation on the feasibility and enhancement methods of wind power utilization in high- rise buildings of Hong Kong, Renew Sustain Energy Rev (2008), doi:10.1016/j.rser.2007.11.01
- Mertens, S. (2002). Wind description for roof location of wind turbines; a design guideline or the required height of a wind turbine on a horizontal roof of a mid- to high-rise building, Global Windpower, Paris, France, Fig 5. 20

- Mertens, S. (2003). The wind conditions at flat roofs for small wind turbines, EWEC 2003, Madrid. Spain.
- Mithraratne, N. (2009). Roof-top wind turbines for microgeneration in urban houses in New Zealand, *Energy and Buildings*, Volume 41, Issue 10, October 2009, Pages 1013-1018, ISSN 0378-7788
- ODPM (2004). Planning Policy Statement 22: Renewable Energy, ISBN 978011739242  
<http://www.communities.gov.uk/documents/planningandbuilding/pdf/147444.pdf>
- Paraschivoiu, I. (2002). "Wind Turbine Design With Emphasis On Darrieus Concept", Polytechnic International Press
- Peacock, A.D. ; Jenkins, D. ; Ahadzi, M. ; Berry, A. ; Turan, S. (2008). Micro wind turbines in the UK domestic sector, *Energy and Buildings*, Volume 40, Issue 7, 2008, Pages 1324-1333, ISSN 0378-7788
- Phillips, R.; Blackmore, P.; Anderson, J.; Clift, M.; Aguilo-Rullan, A.; Pester, S. (2007). Micro-wind turbines in urban environments - an assessment Nov 30, 2007 ISBN 978-1-84806-021-0
- Renewable UK (2010) Small Wind Systems UK Market Report,  
<http://www.bwea.com/small/index.html>, April 2010
- Scottish Government (2009). The Climate Change (Scotland) Act 2009,  
[www.scotland.gov.uk/Topics/Environment/climatechange/scotlands-action/climatechangeact](http://www.scotland.gov.uk/Topics/Environment/climatechange/scotlands-action/climatechangeact)
- Sharpe, T. (2008). Building Mounted Wind Turbines on Existing Multi-Storey Housing, Open House International, September 2008, 0168-2601
- Sharpe, T. (2010) CROSSFLEX: Concept and early development of a true building integrated wind turbine *Energy and Buildings* Article in Press, Accepted Manuscript, Elsevier B.V.
- Solomon, S.; Qin, D; Manning, M.; Chen, Z.; Marquis, M.; Averyt, K.B.; Tignor, M. and Miller, H.L. (eds.) (2007). Contribution of Working Group I to the Fourth Assessment Report of the Intergovernmental Panel on Climate Change, 2007 Cambridge University Press.
- Steemers, K.; Baker, N.; Crowther, D.; Nikolopoulou, M; Clocquet, R. (1996), 'Project ZED, Modelling environmental characteristics of urban forms,' *Solar Energy in Architecture and Urban Planning*, H. S. Stephens, Bedford, pp. 4-7,
- Stern, N. (2007). The Economics of Climate Change, *The Stern Review*, Cabinet Office - HM Treasury ISBN-13: 9780521700801
- Strickland, H. (1975). "The Darrieus Turbine: A Performance Prediction Model Using Multiple Streamtubes", Sandia Laboratories Energy Report 1975
- Taylor, D. (1998), Using buildings to harvest wind energy, *Building Research and Information*, Volume 26, Number 3, 1 May 1998 , pp. 199-202
- UK Government (2009). The Climate Change Act (2008).  
[http://www.decc.gov.uk/en/content/cms/legislation/en/content/cms/legislation/cc\\_act\\_08/cc\\_act\\_08.aspx](http://www.decc.gov.uk/en/content/cms/legislation/en/content/cms/legislation/cc_act_08/cc_act_08.aspx)
- UK Government (2010). The Feed-in Tariffs (Specified Maximum Capacity and Functions) Order 2010, STATUTORY INSTRUMENTS 2010 No. 678, Electricity.

- Wang, F.; Bai, L.; Fletcher, J.; Whiteford, J.; Cullen, D. (2008). Development of small domestic wind turbine with scoop and prediction of its annual power output *Renewable Energy* Volume 33, Issue 7, July 2008, Pages 1637-1651
- Watson, S. J. ; Infield, D. G.; Barton, J. P. ; Wylie, S. J. (2007). Modelling of the Performance of a Building-Mounted Ducted Wind Turbine. *Journal of Physics: Conference Series* 75 (2007) 012001 doi:10.1088/1742-6596/75/1/012001



## **Paths to Sustainable Energy**

Edited by Dr Artie Ng

ISBN 978-953-307-401-6

Hard cover, 664 pages

**Publisher** InTech

**Published online** 30, November, 2010

**Published in print edition** November, 2010

The world's reliance on existing sources of energy and their associated detrimental impacts on the environment- whether related to poor air or water quality or scarcity, impacts on sensitive ecosystems and forests and land use - have been well documented and articulated over the last three decades. What is needed by the world is a set of credible energy solutions that would lead us to a balance between economic growth and a sustainable environment. This book provides an open platform to establish and share knowledge developed by scholars, scientists and engineers from all over the world about various viable paths to a future of sustainable energy. It has collected a number of intellectually stimulating articles that address issues ranging from public policy formulation to technological innovations for enhancing the development of sustainable energy systems. It will appeal to stakeholders seeking guidance to pursue the paths to sustainable energy.

### **How to reference**

In order to correctly reference this scholarly work, feel free to copy and paste the following:

Tim Sharpe (2010). The Role of Aesthetics, Visual and Physical Integration in Building Mounted Wind Turbines - an Alternative Approach, Paths to Sustainable Energy, Dr Artie Ng (Ed.), ISBN: 978-953-307-401-6, InTech, Available from: <http://www.intechopen.com/books/paths-to-sustainable-energy/the-role-of-aesthetics-visual-and-physical-integration-in-building-mounted-wind-turbines-an-alternat>

**INTECH**  
open science | open minds

### **InTech Europe**

University Campus STeP Ri  
Slavka Krautzeka 83/A  
51000 Rijeka, Croatia  
Phone: +385 (51) 770 447  
Fax: +385 (51) 686 166  
[www.intechopen.com](http://www.intechopen.com)

### **InTech China**

Unit 405, Office Block, Hotel Equatorial Shanghai  
No.65, Yan An Road (West), Shanghai, 200040, China  
中国上海市延安西路65号上海国际贵都大饭店办公楼405单元  
Phone: +86-21-62489820  
Fax: +86-21-62489821

© 2010 The Author(s). Licensee IntechOpen. This chapter is distributed under the terms of the [Creative Commons Attribution-NonCommercial-ShareAlike-3.0 License](#), which permits use, distribution and reproduction for non-commercial purposes, provided the original is properly cited and derivative works building on this content are distributed under the same license.