



9th International Conference on Applied Energy, ICAE2017, 21-24 August 2017, Cardiff, UK

## Indoor environmental quality (IEQ) analysis of a low energy wind catcher with horizontally-arranged heat transfer devices

John Calautit<sup>a</sup>, Angelo Aquino<sup>b\*</sup>, Dominic O'Connor<sup>b</sup>, Sheen Cabaneros<sup>b</sup>, Sally Shahzad<sup>c</sup>, Saeed Wazed<sup>b</sup>, Tom Garwood<sup>b</sup>, Katrina Calautit<sup>a</sup>, Ben Hughes<sup>b</sup>

<sup>a</sup>Department of Architecture and Built Environment, University of Nottingham, Nottingham NG7 2RD, UK

<sup>b</sup>Department of Mechanical Engineering, University of Sheffield, Sheffield S10 2TN, UK

<sup>c</sup>College of Engineering, University of Derby, Derby DE22 3AW, UK

---

### Abstract

Windcatchers are natural ventilation systems based on the design of traditional architecture, intended to provide ventilation by manipulating pressure differentials around buildings induced by wind movement and temperature difference. Though the movement of air caused by the wind catcher will lead to a cooling sensation for occupants, the high air temperature in hot climates will result in little cooling or thermal discomfort to occupants. In order to improve the cooling performance by wind catchers, heat transfer devices were incorporated into the design. This work will investigate the indoor environment quality performance of a roof-mounted cooling windcatcher integrated with horizontally-arranged heat transfer devices (HHTD) using Computational Fluid Dynamics (CFD) and field test analysis. The windcatcher model was incorporated to a 5mx5mx3m test room model. The study employed the CFD code FLUENT with the standard k- model to conduct the steady-state RANS simulation. For the indoor CO<sub>2</sub> concentration analysis, a simplified exhalation model was used and the room was filled with 12 occupants. The CO<sub>2</sub> concentration analysis showed that the system was capable of delivering fresh air inside the space and lowering the CO<sub>2</sub> levels. Thermal comfort analysis using the Predicted Mean Vote (PMV) was conducted whereby the measurements ranged from slightly-cool (-0.96) to slightly warm range (0.36 to 0.60). Field test measurements were carried out in the Ras-Al-Khaimah (RAK), UAE during the month of September. Numerical model was validated using experimental data and good agreement was observed between both methods of analysis.

© 2017 The Authors. Published by Elsevier Ltd.

Peer-review under responsibility of the scientific committee of the 9th International Conference on Applied Energy.

*Keywords:* Built environment; Computational Fluid Dynamics (CFD); heat transfer devices; natural ventilation; passive cooling

---

\* Corresponding author. E-mail address: [aaquino1@sheffield.ac.uk](mailto:aaquino1@sheffield.ac.uk)

## 1. Introduction and literature review

The way in which energy is generated and used has a direct impact on greenhouse gas (GHG) emissions and the economy. The built environment is one of the main end-user of energy; therefore, the use of new technologies to reduce the energy consumption of buildings is a key issue in the design and planning of more sustainable cities. The rapid growth of countries in the Middle East such as UAE and Qatar placed them at the top of the global carbon footprint. The extreme hot climate, the low cost in these regions and the demand for higher levels of comfort has led to the use of mechanical cooling units in both residential and commercial buildings, where most units are operated for 24 hours per day, all year round. Heating, Ventilation and Air-conditioning (HVAC) is responsible for up to 60% of the energy consumed by buildings and even higher during summer months [1, 2]. Reducing the substantial energy requirements of mechanical HVAC services has the potential to significantly lower the energy consumption of the built environment heavily reliant on such systems such as commercial buildings, schools and office spaces [3]. An example of a passive ventilation technology is a windcatcher which is an architectural component of traditional Middle Eastern buildings which captures the outdoor wind at high elevation and directs it to the interior [4, 5].

Windcatchers have been installed in buildings in temperate climates such as the UK, particularly in schools and offices [5]. Windcatcher ventilation is particularly effective for night time cooling as this is when there is the greatest differential between indoor and outdoor temperatures. However unlike mechanical cooling, windcatchers are ineffective at reducing the temperature of supply air [6]. It primarily relies on the outdoor temperature for cooling and in warm or hot climates, this could cause further discomfort to occupants during summer if the air is not pre-cooled before entering the occupied space. This places a limit on the application of windcatchers in warm or hot climates. Several works have attempted to address this by integrating evaporative cooling and heat transfer devices [6-8]. The windcatcher with evaporative cooling have shown promising results particularly in dry conditions, for example reductions up to 15°C were observed, depending on the local climatic conditions [7]. However, there are several drawbacks associated with evaporative cooling such as high operation and maintenance cost, ineffectiveness in warm, moderate to high humid conditions [8]. In addition, evaporative coolers use a substantial amount of water to run which could be considered wasteful in arid climates [8]. Several works [8,9] have incorporated heat transfer devices into the internal channel of the windcatcher to reduce the supply airflow temperature (Figure 1). Several researchers have attempted to improve the operation of the windcatcher in different climates; cold [10] and humid [11].



Fig. 1. (a) A roof mounted windcatcher with heat transfer devices (b) schematic diagram of the windcatcher operation.

In our previous works [2,8-9], a cooling system that combines passive ventilation and cooling was developed to the prototype stage. The system was designed to complement or replace energy-intensive mechanical HVAC in warm-hot climates and reduce energy usage and carbon emissions. The system is self-contained, compact and suitable for retrofitting to existing buildings. The device functions by capturing hot outdoor airflow at roof level and redirecting it through a series of cylindrical HTD [12]. The heat from the incoming hot air evaporates the working fluid in the sealed HTD. The vapor flows to the other end, when it condenses, giving up the heat to the fluid circulating inside the closed-loop cool sink. This will maintain the operating conditions and repeat the cyclic operation of the HTD. Dampers are mounted at the bottom of the unit to control the delivery rate of air, as fluctuations in external wind speed greatly affect the air movement rate. The cooled air is supplied to the room

below the channel via the ceiling diffusers.

Though the analysis of the simulation results indicated promising incoming air temperature reduction, there was little evidence relating to how the system would improve the indoor environment quality in the previous research. Therefore, the next step is to demonstrate the capabilities of the system to provide adequate thermal comfort and indoor air quality in buildings. In the present study, Computational Fluid Dynamics (CFD) simulations based on the 3D Reynolds-Averaged Navier-Stokes equations are employed to assess the indoor ventilation and cooling potential of the passive cooling windcatcher system employed in a hot climate. The thermal comfort analysis will be carried out using the Predicted Mean Vote (PMV) method. The simplified exhalation model (constant exhalation) will be used for the analysis of the impact of the windcatcher on the indoor CO<sub>2</sub> distribution. The simulation method will be validated using full scale field measurements.

## 2. Research methodology

### 2.1. CFD modelling

ANSYS FLUENT 15 software was used to conduct the steady-state Reynolds averaged Navier–Stokes equation (RANS simulation) which employed a control-volume-based technique for solving the flow equations. The standard  $k-\epsilon$  turbulence model was used, which is a well-established method in research on windcatcher natural ventilation [7]. Second-order upwind scheme was used to discretise all the transport equations. The numerical code used the semi-Implicit method for pressure-linked equations (SIMPLE) algorithm for the velocity-pressure coupling of the computation. The governing equations are not repeated here but available in the ANSYS FLUENT guide.

The windcatcher (Figure 1) was created using commercial CAD modeller. The CAD solid data was imported into ANSYS DesignModeller (pre-processor) to generate a fluid domain. The domain (Figure 2a) was separated into three parts: the windcatcher, indoor and outdoor environment. The windcatcher was incorporated to the indoor domain with the dimensions of 5m x 5m x 3m, representing a small room. It was assumed that the windcatcher was supplying airflow at 100% (fully open), therefore dampers were not modeled in the system. The dimension (20 mm outer diameter) and spacing (50mm horizontal and 20mm vertical) of the HTD located downstream of the windcatcher channel were based on earlier work [8-9]. The cool sink was not included in the modelling for simplification. Figure 2a shows the computational domain used for the analysis of the room with a windcatcher.

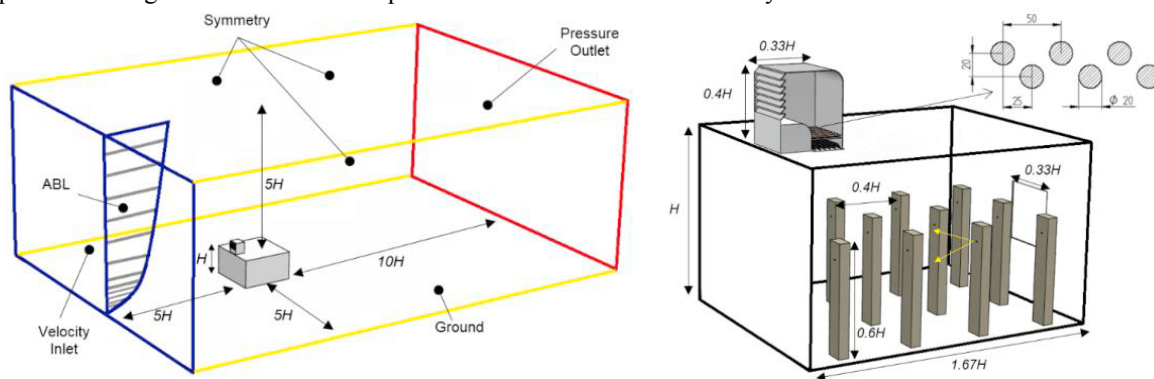

Fig. 2. (a) A roof mounted windcatcher with heat transfer devices (b) schematic diagram of the windcatcher operation.

The domain was sufficiently large to prevent artificial acceleration of the flow. The length of the up-stream domain was kept short, 5 times the height of the test room, to avoid the unintended existence of stream-wise gradients while satisfying the recommendations. The length of the down-stream domain was 15 times the height of test room, sufficiently long to allow the wake region development behind test room [13]. The windcatcher model was based on a typical 1m<sup>2</sup> roof-mounted device. Louvers angled at 45° were fixed at regular intervals in the windcatcher openings to allow air to pass through. Figure 2b shows a schematic of the windcatcher 3D model and also the spacing between the heat transfer devices (in mm).

Due to the complex geometry of the windcatcher model, an unstructured-grid technique was employed to discretise the domain [14]. The advanced size function in ANSYS Meshing was used to precisely capture the geometry while maintain a smooth growth rate between regions of curvature. In order to capture accurately the flow-

fields near the critical areas of interest (i.e. louvers and HTD) in the simulation, size functions were applied in those surfaces. The total number of the grid elements was 5.6 million. The selected resolution of the grid was based on the grid sensitivity analysis and convergence analysis on several grids (4.6 to 9.2 million).

The boundary conditions were set using the guidelines [15] for the simulation of flows in the urban environment. The mean velocity of the approach flow obeyed a power-law with  $\alpha=0.25$ , which corresponds to a sub-urban terrain. The top and side boundaries were defined as symmetry and the outlet surfaces of the domain was set as zero-static pressure [16]. The inlet temperature was set to 21-40°C and relative humidity was set to 34-67% which are typical average in Ras-Al-Khaimah (RAK). The wall temperature of the HTD was set to 20°C [8,9].

For the CO<sub>2</sub> distribution simulation, the room was filled with 12 occupants (equally distributed inside the room). A simplified exhalation (constant exhalation) model [17] was used for the analysis. The model of the occupant was simplified to a 1.80m x 0.30m x 0.17m cuboid shape. The area for the mouth opening is equal to 0.13m x 0.10m [17]. Average value of 6 l/min of exhaled air was assumed for the simulation [17].

## 2.2. Experimental testing an validation

Field testing measurements were carried out in the Jazira Hamra area of Ras-Al-Khaimah (RAK), United Arab Emirates (UAE). The test location (Figure 3a) is within an upscale residential area which includes several housing communities such as the Hamra Village. The climate of RAK can be characterised as a hot-desert climate with very hot summers and mild winters. High temperatures can be expected from June to August, with a mean temperature ranging between 37-40°C. The tests were carried out during the month of September (Sept. 17 – 18 of 2014) between 11AM to 4PM. The prevailing winds in RAK are from the northern direction (N-NNW-NW). Therefore, the opening of the windcatcher was positioned to face the predominant wind. The average wind speed in RAK is between 3.60m/s-4.60m/s but during the days of test wind speeds went up to about 5.70-6.00m/s. A 1x1m<sup>2</sup> prototype of the cooling windcatcher was manufactured (Figure 1a) and installed on top of an unoccupied 3x3x3m<sup>3</sup> test space as displayed in Figure 1a. The 20mm HTD were arranged inside the downstream of windcatcher channel as described in Section 2.1. The cool sink was fed by water at approximately 20°C. The walls and roof of the test room was built using insulated studwork. A small cut-out at the back of the room serves as an outlet. The temperature was measured using type-k thermocouple: outdoor, supply air (3 equally-spaced thermocouples downstream of windcatcher channel) and HTD wall (1 on surface). The thermocouples were connected to a data logger. The uncertainty associated with the measurement tool was  $\pm 0.6^\circ\text{C}$  at a temperature of 50°C and  $\pm 0.5^\circ\text{C}$  at 0°C.

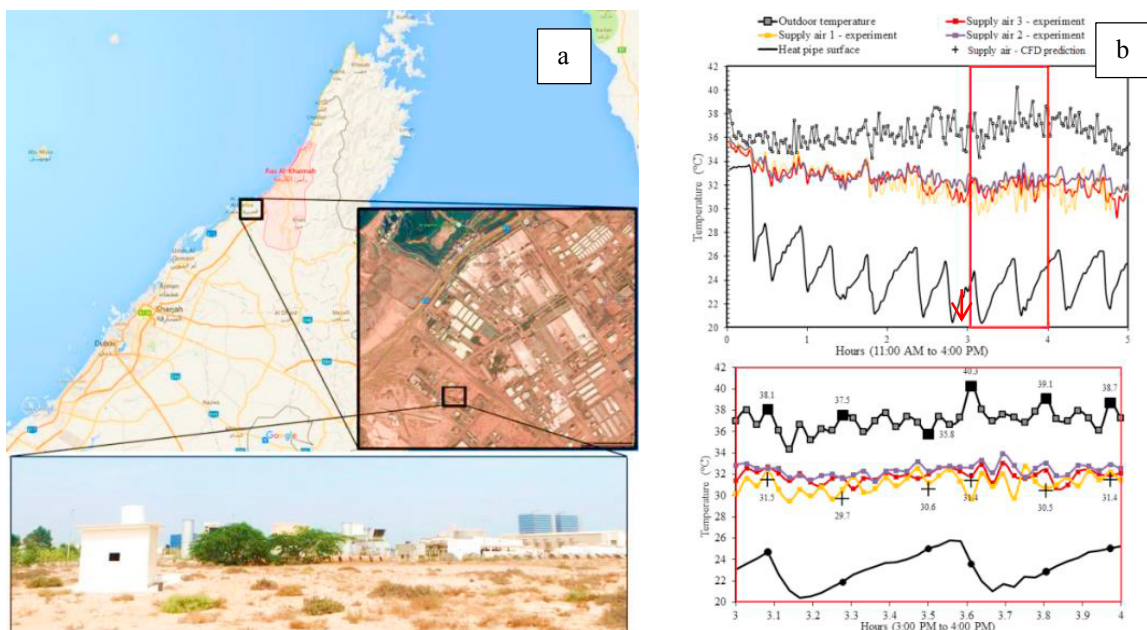

Fig. 3. (a) Experimental field test setup (b) experimental result and validation.

Figure 3b displays the measurements of outdoor air temperature, supply air temperature at the three positions downstream of the windcatcher and HTD surface temperature during the 5-hour testing on (09/18/14) from 11 AM to 4 PM. The windcatcher began to deliver airflow into the test room at 11:30 and the temperature drop ranged between 3°C–4°C during this period. When the wind started to blow consistently within the ±40° wind angle from 1 PM to 4PM and the temperature drop ranged between 3 °C–11.5°C during this period. A detailed view of the temperature measurements from 3 PM to 4 PM is shown at the bottom of Figure 3b. The temperature measurements taken during several periods (03:05, 03:16, 03:30, 03:37, 03:48 and 03:58) were used for the validation of the steady-numerical model. Predicted supply temperatures are added to the chart for comparison with the measured results. As observed, the numerical model in most cases under-predicted the supply temperature, however a similar trend between both methods was observed. The average error between the results was 3.15%.

**3. Results and Discussion**

The ventilation rate is a characteristic of the supply air velocity and the inlet opening subject to the external environment, therefore, it is important that the supply air velocity is maximised. The integration of the HHTD into the windcatcher presents a pressure drop to the air flow, thereby reducing the supply air velocity. This can clearly be seen in Figure 4a, where by the supply air decelerates from approximately 0.80m/s to 0.40m/s. The presence of the HTD slows the supply air, limiting the ventilation rate of the windcatcher. The system supplied between 79.5 to 445L/s at 1-5m/s outdoor wind (in comparison a standard 1x1m multidirectional windcatcher can supply between 135-722L/s [5]). Figure 4b shows the contours of carbon dioxide concentration around the test room with 12 occupants at a centre plane view. As the fresh air enters the test room, the external and internal air mix, diluting the concentration of CO<sub>2</sub> in the test room due to the occupant sources with the lower outdoor air concentration. This brings the average CO<sub>2</sub> concentration in the test room down below the suggested level (1000ppm) at  $U_H=2.2\text{m/s}$ .

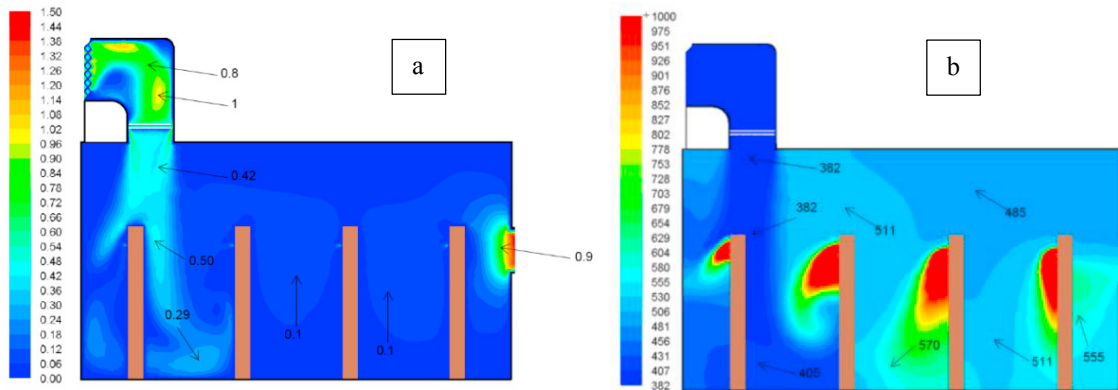

Fig. 4. Contours of (a) air velocity in the test room from a uni-direction windcatcher with HHTD (b) CO<sub>2</sub> distribution in the test room with nine occupants as CO<sub>2</sub> sources at outdoor wind velocity  $U_H=2.2\text{m/s}$ .

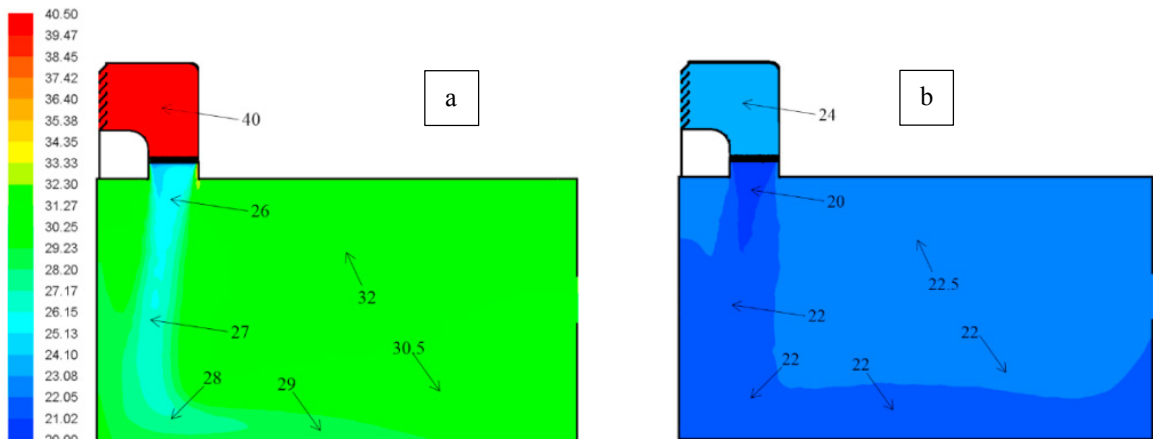

Fig. 5. Contours of air temperature in the test room during (a) summer month (Jul) and (b) winter month (Dec).

Using the weather data for the input values at the boundary conditions, the effect of the heat transfer devices on the incoming air temperature was determined. Figure 5a shows the contours for internal air temperature when the inlet air temperature was set to 40°C, taken as the average temperature in July. As observed, the heat transfer devices had a noticeable effect on the temperature of the incoming air. The column of air below the windcatcher shows that the air temperature drop to 25°C and the average air temperature in the test room was 28–32°C showing an 8–10°C decrease in incoming air temperature. Although this represents a significant reduction in air temperature using a low-energy cooling technology, thermal comfort analysis should be conducted to assess the impact of other environmental factors. The contours for the internal air temperature in the winter month of January is shown in Figure 5b, when the inlet air temperature was set to 21°C. Due to the low inlet air temperature, the temperature reduction due to the HTD was less substantial compared to summer. Figure 6 displays the Predicted Mean Vote (PMV) contours plotted on a horizontal cross-sectional plane in the room (0.5H) representing the thermal comfort levels in the room during the summer month of September, highlighting the impact of high humidity levels on comfort during the summer period. As observed, the PMV values in the left corner area were in the slightly-cool to neutral range (-0.96 to 0.12) while the other areas were in the slightly warm range (0.36 to 0.60). Figure 6b shows the indoor PMV contours during the winter month of December. A similar trend can be observed for the area directly below the windcatcher having a different thermal comfort level than the other zones. The PMV value below the windcatcher was -0.99 or 26% predicted percentage dissatisfied (slightly cool) while the other areas had a PMV value of 0.62-0.66 (12-14% PPD slightly warm).

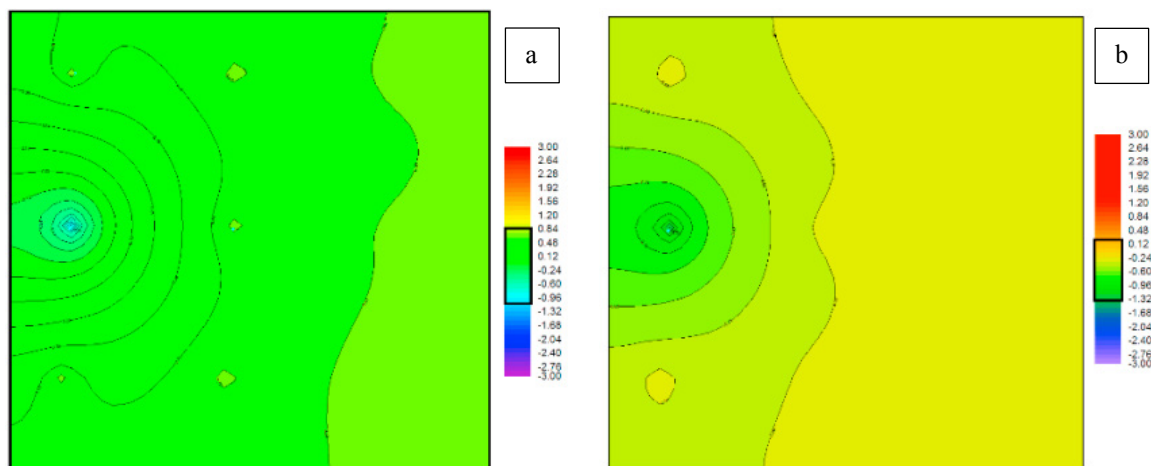

Fig. 6. Contours of Predicted Mean Vote (PMV) thermal comfort distribution in the room during (a) summer (Sep) and (b) winter (Dec).

#### 4. Conclusions

The indoor environmental quality of a building passively ventilated by a windcatcher integrated with low energy cooling technology was assessed through Computational Fluid Dynamics (CFD) analysis and far-field testing in Ras-Al Khaimah (RAK), UAE. Results from the far-field testing were used to validate the CFD analysis, showing a strong agreement between the two sets of results. Air temperature reduction between 8–10°C was achieved using the windcatcher and heat transfer device arrangement during summer months. Thermal comfort analysis using the Predicted Mean Vote (PMV) was conducted whereby the measurements ranged from slightly-cool (-0.96) to slightly warm range (0.36 to 0.60). Guideline levels below 1000ppm are given to ensure occupant health and wellbeing. A supply rate of 1m/s and higher is sufficient to reduce the pollutant concentration below the guideline value. Though the windcatcher integrated with low energy cooling technology was capable of maintaining good indoor air quality and thermal comfort by reducing the incoming air temperature, more testing and development is required.

#### Acknowledgements

The support by the University of Sheffield is gratefully acknowledged. The statements made herein are solely the responsibility of the authors. The technology presented here is subject to a UK patent (WO2015/087305).

## References

- [1] Akeiber H, Nejat P, Majid M, Wahid M, Jomehzadeh F, Famileh I, Calautit JK, Hughes BR, Zaki S, A review on phase change material (PCM) for sustainable passive cooling in building envelopes, *Renewable and Sustainable Energy Reviews* 2016;60:1470-1497.
- [2] Calautit JK, Hughes BR, Nasir DSNM, Climatic analysis of a passive cooling technology for the built environment in hot countries, *Applied Energy* 2017;186:321-335.
- [3] Calautit JK, Hughes BR, Integration and application of passive cooling within a wind tower for hot climates, *HVAC&R* 2014;20:722-730.
- [4] Nejat P, Calautit JK, Majid M, Hughes BR, Zeynali I, Jomehzadeh F, Evaluation of a two-sided windcatcher integrated with wing wall (as a new design) and comparison with a conventional windcatcher, *Energy and Buildings* 2016;126:287-300.
- [5] Calautit JK, Hughes BR, Wind tunnel and CFD study of the natural ventilation performance of a commercial multi-directional wind tower. *Building and Environment* 2014;80:71-83.
- [6] Calautit JK, O'Connor D, Sofotasiou P, Hughes BR, CFD Simulation and Optimisation of a Low Energy Ventilation and Cooling System. *Computation* 2015;3:128-149.
- [7] Hughes BR, Calautit JK, Ghani SA, The Development of Commercial Wind Towers for Natural Ventilation: a review. *Applied Energy* 2012;92:606-27.
- [8] Calautit JK, Chaudhry HN, Hughes BR, Ghani SA. Comparison between evaporative cooling and heat pipe assisted thermal loop for a commercial wind tower in hot and dry climatic conditions, *Applied Energy* 2013; 101:740-755.
- [9] Calautit JK, Hughes BR, Shahzad SS. CFD and wind tunnel study of the performance of a uni-directional wind catcher with heat transfer devices. *Renewable Energy* 2015;83:85-99.
- [10] O'Connor D, Calautit JK, Hughes BR, A Study of Passive Ventilation Integrated with Heat Recovery, *Energy Buildings* 2014;82:799-811.
- [11] O'Connor D, Calautit JK, Hughes BR, A novel design of a desiccant rotary wheel for passive ventilation applications, *Applied Energy* 2016;179:99-109.
- [12] Chaudhry HN, Calautit JK, Hughes BR, Optimisation and analysis of a heat pipe assisted low-energy passive cooling system, *Energy and Buildings*, Volume 143, 2017, Pages 220-233
- [13] Calautit JK, Hughes BR, O'Connor D, Shahzad SS, Numerical and experimental analysis of a multi-directional wind tower integrated with vertically-arranged heat transfer devices (VHTD), *Applied Energy* 2017;185:1120-1135.
- [14] Calautit JK, Hughes BR, A passive cooling wind catcher with heat pipe technology: CFD, wind tunnel and field-test analysis, *Applied Energy* 2016;162:460-471.
- [15] Chaudhry HN, Calautit JK, Hughes BR, Computational analysis of a wind tower assisted passive cooling technology for the built environment, *Journal of Building Engineering* 2015;1:63-71.
- [16] Hosseini SH, Shokry E, Hosseini AJ, Ahmadi G, Calautit JK, Evaluation of airflow and thermal comfort in buildings ventilated with wind catchers: Simulation of conditions in Yazd City, Iran, *Energy for Sustainable Development* 2016;35:7-24.
- [17] Nejat P, Calautit JK, Majid MZ, Hughes BR, Jomehzadeh F., Anti-short-circuit device: A new solution for short-circuiting in windcatcher and improvement of natural ventilation performance, *Building and Environment* 2016;105:24-39.