

WHY CAD TOOLS BENEFIT FROM A SKETCHING LANGUAGE

Borg Jonathan C., Farrugia Philip J., Camilleri Kenneth P., Giannini Franca, Yan X.T., and Scicluna Dawn

Abstract

Despite the fact that Computer-Aided Design (CAD) tools are used during the early design stages to aid external representation with the generation of 3-dimensional (3D) models, paper-based freehand sketching is still the most intuitive method used amongst practicing designers due to its efficiency in externalising conceptual design solutions. Sketch recognition systems are therefore being developed with the aim to bridge the gap between freehand sketching and CAD tools. However, given the intrinsic ambiguity and incompleteness of freehand sketches, it is almost impossible to achieve the complete automatic generation of a 3D model from any hand-made sketch. Thus, one of the key research tasks in the development of sketch recognition systems concerns the exploration of sketching methods which are able to handle the trade-off between the preservation of manual sketching freedom and the ease of computer recognition. Based on this approach and as a step towards integrating 'paper-based' freehand sketching with CAD tools, this paper discloses the development and evaluation of two preliminary 'sketching languages' that support the generation of a virtual component model for further processing by computational product development tools. Furthermore this paper reports the findings of a survey which reveal that future CAD tools benefit from a sketching language.

Keywords: early phases of design, sketching symbols, sketch recognition, user interface

1 Problem background

The design process can be considered to consist essentially of four stages, namely, task clarification, conceptual, embodiment and detail stages [1]. It is well known that the conceptual stage is the most important one as it influences *all* the other product life-phases in terms of performance measures such as *cost*, *time* and *quality* [2]. In spite of this, *most* of the commercially computational design tools are suitable for later design stages (see Figure 1).

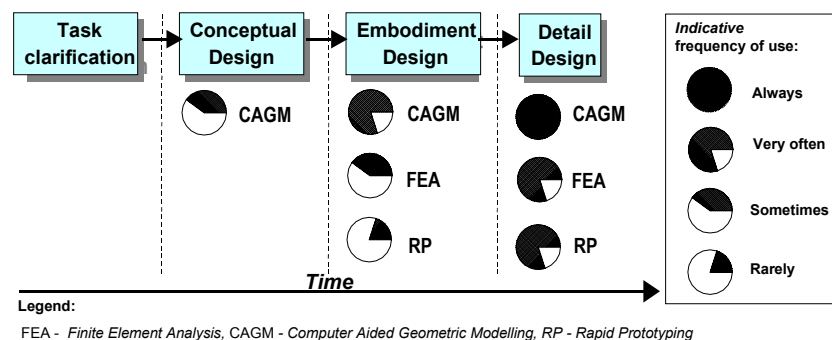

Figure 1. Frequency of use of design tools during the "form" design stages.

Although CAD tools, more specifically, Computer-Aided Geometric Modelling (CAGM) programs are also being used during the conceptual design stage [3], paper-based *freehand sketching* is still the most useful and intuitive approach used amongst designers for the rapid exploration of their early design concepts [4]. From a survey conducted by Romer et. al [3], it has been found that sketches are significantly more frequently used *before* rather than *during* CAD-work. This is mostly attributed to the fact that the user interfaces (UIs) of most commercial CAD tools follow the *WIMP* (Window, Icon, Menu, and Pointing device) paradigm [5], thereby, lacking the fluidity of freehand sketching and subsequently being of detriment to the creative flow of design ideas [6]. Furthermore, this type of user-interface puts an additional burden on designers since they have to transfer their paper-based sketches to CAD systems, which is a time-consuming process [7]. As argued in [3], the combined use of sketches and CAD tools highlights the need to investigate the interface of these media to avoid loss of time and information when changing between manual sketching and CAD tools.

Therefore, the efficient transfer of paper-based sketches into CAD representation would be beneficial for designers [8] for various reasons. For instance, as argued in [4], the generation of *imprecise* virtual models is very useful during early design since the component model is constructed after analysis and not vice versa. In addition, the rapid generation of 3D CAD models from freehand sketches would allow designers to obtain 3D physical models of their conceptual form solutions, given that *physical modelling* is used by designers during early design [9].

With the aim to exploit such benefits and to integrate freehand sketching with CAGM tools, various sketch recognition systems have been developed. However as argued in [8], the development of such systems is difficult mainly due to the fact that sketches often involve vague information and the understanding of sketches differ from each designer. To compound these problems further, although many drawing standards (such as *ANSI*, *DIN*, *BS*, *JIS*) have been established for detail design drawings, no standards are available for sketches. This makes computer sketch recognition more difficult. Collectively these issues suggest that the research problem domain that needs to be explored concerns the development of a sketching approach which exploits of a compromise between preserving the natural way of freehand sketching and the formality required for computer recognition [7] (see Figure 2). Although many sketch recognition systems adopted a sketching approach [6], the sketching medium used in these systems consists of a graphics tablet and stylus, which is not as portable and available as paper. Hence there is the need to develop a sketching approach that links '*paper-based*' sketching with CAGM tools.

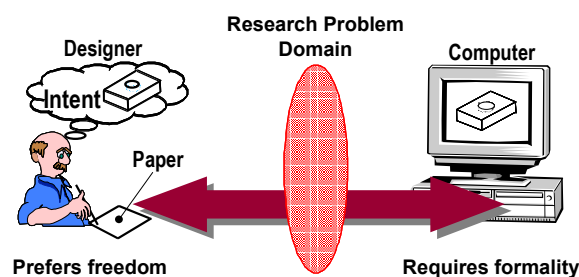

Figure 2. Trade-off between paper-based sketching freedom and computer formality.

2 Research goal

Based on the trade-off illustrated in Figure 2, the on-going research goal reported in this paper concerns the development and evaluation of alternative '*paper-based*' '*sketching languages*'

that support the generation of a virtual component model for further processing by computational product development tools. A related research goal explored in this paper concerns the investigation into 'why CAD tools benefit from a sketching language.'

Since this research is in its infancy, research efforts are currently being focused only on a limited domain of *prismatic* components constituted of a rectangular base having face-based features (such as bosses, pockets, holes, threads, counterbores and countersunks).

3 Concept of proposed alternative Sketching Languages

Sketching can be considered as a *natural language*, the latter defined as the infinite set of strings (with *phonology*, *syntax* and *semantics*) governed by a *grammar* [10]. In the case of this research, phonology is irrelevant since the developed sketching languages are intended for written communication. The first sketching language developed has been *SKL1*. However, due to the difficulties encountered by users in using this language, namely, to insert numbers (as described in section 3.1) in confined spaces between sketching entities, an alternative sketching language (*SKL2*) is concurrently developed. In the next two sub-sections, the grammar of these preliminary sketching languages is explained.

3.1 Grammar of Sketching Language 1 (*SKL1*)

SKL1 utilises a single 2-dimensional (2D) view representation, more specifically a plan, to represent the designer's intended component. To avoid any misinterpretation that may result when using only one 2D view, *SKL1* uses a two-digit number system [11], which constitutes part of the *syntax* of the language. Another syntactical rule employed in *SKL1* concerns the setting of the datum at the bottom of the component as indicated in Figure 3. The *alphabet* of *SKL1* consists essentially of a pair of numbers (Z_1, Z_2) which is placed on top of each sketching entity to present depth information. The first number (Z_1) indicates the starting Z value of an entity above the Z -datum, while the second number (Z_2) represents the absolute ending Z value of the same entity. Figure 3, illustrates simple components represented by *SKL1* to explain the concept of depth representation employed in this language. A library of sketching symbols representing the plan of face-based features (and resembling to some extent standard symbols used in detail drawings) has been established to enable designers to quickly learn *SKL1*, whilst at the same time simplifying sketch recognition.

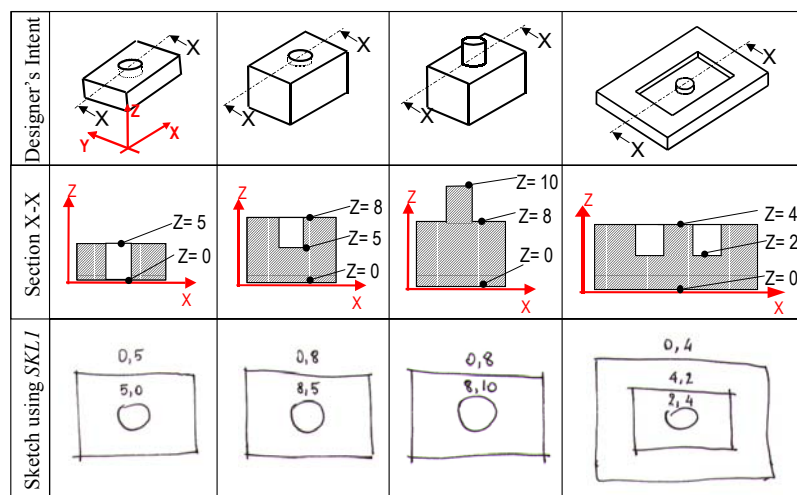
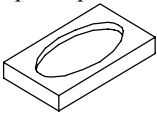
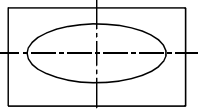
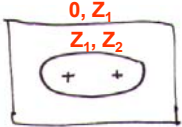
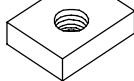
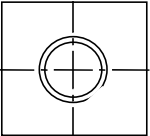
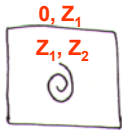
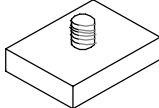
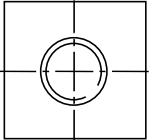
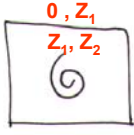

Figure 3. Examples of how components are sketched using *SKL1*.

As a result, the *semantics* of this sketching language (i.e. the geometric meaning of features conveyed by *SKL1*) is made up of two elements: (i) the sketching symbols representing the plan of face-based features (such as those illustrated in Table 1) and (ii) the pair of numbers associated with each sketching entity.

Table 1. Sketching symbols employed in *SKL1*.

| Intended feature | Standard drawing convention of plan | Symbol used in <i>SKL1</i> |
|---|---|---|
|  |  |  |
|  |  |  |
|  |  |  |

With the objective of eliminating the numbers present in *SKL1*, another alternative sketching language (*SKL2*) has been developed whose concept is explained next.

3.2 Grammar of Sketching Language 2 (*SKL2*)

In this sketching language, the geometric meaning of face-based features (i.e. the semantics of *SKL2*) is represented by means of a 2D plan (using the same symbols of *SKL1*) and also a 2D cross-sectional view passing through *all* the features constituting the intended component. Figure 4 depicts the components that were previously considered in *SKL1*, as sketched by *SKL2*. It may be noted that the sectional views are composed of *sectional sketching symbols* (see Figure 4). More examples of such symbols are illustrated in Table 2.











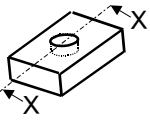
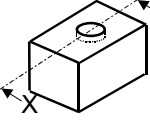
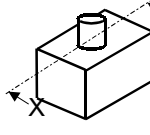
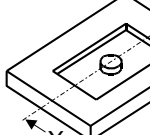

| | | | | | |
|--------------------------------------|-------------------|---|---|---|---|
| Component sketched using <i>SKL2</i> | Designer's Intent |  |  |  |  |
| | Plan |  |  |  |  |
| | Section X-X |  |  |  |  |

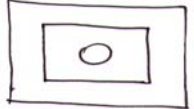
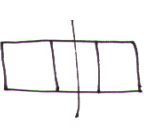
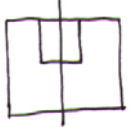
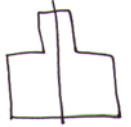
Figure 4. Examples of components sketched with *SKL2*.

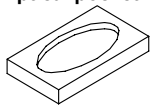
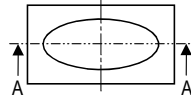
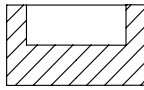
As syntactical rules, it has been established that the sectional line is omitted in the plan and no hatching is present in the sectional view. Since numbers are not utilised in this case, the grammar of *SKL2* governs the semantics and syntax only. Of more importance, it is worth noting that when using this sketching language it is assumed that one sectional view is sufficient to represent all the face-based features. To eliminate this problem, additional sectional views need to be sketched depending on the complexity of the component.

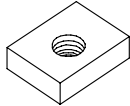
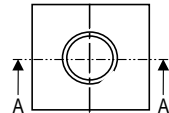
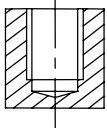
Table 2. Plan and sectional sketching symbols employed in *SKL2*.

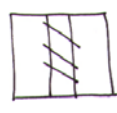
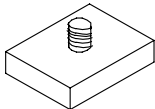
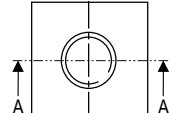
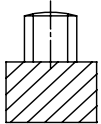
| Intended feature | Standard drawing conventions | | Symbols used in <i>SKL2</i> | |
|---|---|--|--|--|
| | Plan | Section A-A | Plan | Section A-A |
| Elliptical pocket  |  |  |  |  |
| Internal thread  |  |  |  |  |
| External thread  |  |  |  |  |

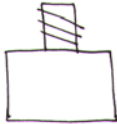
4 Evaluation approach

This section discloses the evaluation approach adopted to first investigate whether or not CAD tools benefit from a sketching language and secondly to critically assess the ease or otherwise of using *SKL1* and *SKL2*. The evaluation has been carried out in three countries, namely, Malta, UK and Italy. Structured interviews were carried out with 43 evaluators purposely having a different background; 21 practicing industrial designers, 10 final year mechanical engineering degree students and 12 postgraduate students in engineering design. The evaluators were first verbally briefed about the objective of the survey and were then asked to fill in a questionnaire related to the use of a sketching language, based on whether participants:

1. still use sketching for thought externalization during conceptual design;
2. prefer to use a 'stylus and graphics tablet' for freehand sketching instead of the traditional pencil and paper;
3. ever had to verbally explain a sketch which was not readily understood by their colleagues;
4. are willing to accept a standard sketching language, provided a virtual CAD or physical model can be rapidly and automatically generated from the sketch;
5. consider the generation of such models useful.

The evaluators were then given a written explanation of the underlying concept of *SKL1*. Afterwards they were asked to manually sketch a given component, namely, a mould cavity insert (see Figure 5a) by using the first proposed sketching language (as illustrated in Figure 5b) and then to answer a few questions to reveal their impressions of using *SKL1*. Finally, in

a similar task, the participants had to sketch the same component but using *SKL2* (see Figure 5c), and then had to answer a set of questions. The two set of questions were aimed at:

1. assessing two attributes of the sketching languages, namely, (i) the *easiness* or not exhibited by the participants in understanding the languages' underlying concept and (ii) the language's *user-friendliness*;
2. investigating if the participants would accept to use sketching symbols;
3. investigating if the participants are willing to *learn* and *adopt* either *SKL1* or *SKL2*;
4. determining which sketching language (if any) is currently preferred by the participants.

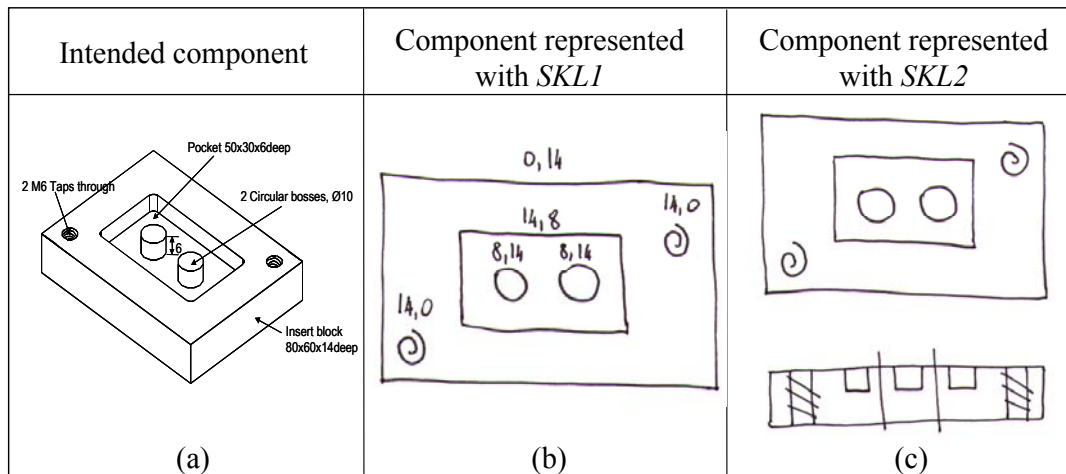

Figure 5. Component sketched by evaluators using the two sketching languages.

5 Evaluation results

Section 5.1 below presents *global* results related to the use of a sketching language, while section 5.2 presents the global results associated with the critical evaluation of *SKL1* and *SKL2*. Results by evaluator category (e.g. postgraduate students vs. industrial designers) are available in [12].

5.1 Results relating to the use of a sketching language

The results reveal that 93% of the participants still use freehand sketching to externalise their solution concepts during early design. With regards to the sketching medium, it should be noted that the results obtained are based on the evaluators' perceptions of a graphics tablet and stylus and not actually on their impressions based on hands-on experience in using such device. In fact, Table 3 shows that 42% of the evaluators were not sure which medium to use. Since this test was flawed, deeper investigation is necessary to determine which sketching medium the participants prefer. 98% the participants reported that they had to explain their sketch to their colleagues sometime or another, since it was not readily understood. Two major reasons attributed to this were (i) that due to the spontaneity of sketching, the participants sometimes lacked details in their sketch, and (ii) the participants' drawing skills were limited, especially when drawing 3D objects.

As shown in Table 3, 42% of the evaluators were willing to accept a standard sketching language, provided that a virtual CAD or physical model could be automatically generated

from the sketch. The most common reason for this was that the eventual development of such a system would contribute towards a reduction in the product’s time-to-market. The other 49% reported that they were not sure, mostly because they still have to experience the advantages of a sketching language in practice. Only 9% said that they still prefer to sketch in their usual style mainly because they feel that a sketching language would hinder the spontaneity inherent in sketching. Referring to Table 3, the majority of the evaluators (86%) agree that the generation of virtual or physical models from sketches would be useful. The most common reasons reported were that a model (i) would assist designers to detect any weakness in the concept that may not be easily detected by a simple sketch, and (ii) would allow designers to discuss better the concept with other design team members.

Table 3. Results relating to the use of a sketching language.

| Question | Frequency (expressed as %) | | |
|--|----------------------------|----------|----|
| | Yes | Not sure | No |
| Would you prefer to use a stylus and graphics tablet to carry out your sketching activity, instead of pencil and paper? | 35 | 42 | 23 |
| Instead of your usual manner of sketching, would you accept a standard sketching language, provided that a virtual CAD or physical model can be generated from the sketch? | 42 | 49 | 9 |
| Do you think that the generation of such models would be useful during early design? | 86 | 7 | 7 |

Collectively, the results obtained indicate that a sketching language would be beneficial for CAD tools, for two major reasons: (i) freehand sketching is still widely used and (ii) a virtual CAD or physical model is very useful for designers during early design.

5.2 Evaluators' preference between SKL1 and SKL2

The results in Table 4 indicate that the participants found it relatively easy to understand the concept of both sketching languages. On the other hand, SKL2 was found to be user-friendlier when compared to SKL1 (see Table 5).

Table 6 reveals that the majority of the evaluators would accept to use a library of sketching symbols such as those proposed both in SKL1 and SKL2 to represent features in their sketch. The results in Table 6 also indicate that the evaluators prefer to learn SKL2 rather than SKL1.

However, independent of the language, many participants reported that a standard sketching language would contribute to enhance the understanding between designers of the intended sketch. Less than 20% of the participants reported that they are *not* likely to learn either SKL1 or SKL2. Furthermore, the results in Table 6 indicate that the participants were more likely to learn the proposed sketching languages rather than to adopt them, although a good percentage were still willing to do so (60% for SKL1 and 63% for SKL2). This may be largely devoted to the fact that currently the two sketching languages support a limited range of components to be practically useful.

Table 4. Comparison of results of *SKL1* and *SKL2* in terms of their ease of understanding.

| Question | | Frequency (expressed as %) | | | | |
|--|--------------|----------------------------|------|---------|-----------|----------------|
| | | Very easy | Easy | Average | Difficult | Very difficult |
| How easy it was for you to understand the concept of | <i>SKL1?</i> | 14 | 49 | 28 | 7 | 2 |
| | <i>SKL2?</i> | 19 | 49 | 23 | 9 | 0 |

Table 5. Comparison of results of *SKL1* and *SKL2* in terms of their user-friendliness.

| Question | | Frequency (expressed as %) | | | | |
|--|--------------|----------------------------|------|---------|------|-----------|
| | | Very good | Good | Average | Poor | Very poor |
| How do you rate the user-friendliness of | <i>SKL1?</i> | 9 | 44 | 37 | 5 | 5 |
| | <i>SKL2?</i> | 19 | 48 | 26 | 7 | 0 |

Table 6. Comparison of other results obtained for *SKL1* and *SKL2*.

| Question | | Frequency (expressed as %) | | | | |
|---|--------------|----------------------------|--------------|--------------|----------------|------------|
| | | Definitely yes | Probably yes | Probably not | Definitely not | Don't know |
| Would you accept to use a library of sketching symbols to represent features in your sketch such as those proposed in | <i>SKL1?</i> | 14 | 58 | 19 | 7 | 2 |
| | <i>SKL2?</i> | 12 | 68 | 16 | 2 | 2 |
| Would you consider to learn | <i>SKL1?</i> | 19 | 62 | 14 | 5 | 0 |
| | <i>SKL2?</i> | 23 | 63 | 12 | 2 | 0 |
| Would you consider to adopt | <i>SKL1?</i> | 7 | 60 | 21 | 7 | 5 |
| | <i>SKL2?</i> | 5 | 63 | 16 | 7 | 9 |

Table 7 clearly shows that for the given component the participants prefer to use *SKL2* rather than *SKL1* (58% compared to 26%). The most common reason reported was attributed to the fact that *SKL2* is visually more indicative and intuitive when compared to *SKL1*. In addition from the analysis of sample sketches, it was observed that participants encountered some difficulties with *SKL1* in inserting numbers to denote depth information due to lack of space between sketching entities. 7% of the evaluators reported that they would use both languages – one industrial designer stated that both languages prove to be easy to learn and to use once understood. Finally 9% of the participants do not like any of the proposed sketching languages. One industrial designer remarked that he prefers to ‘transfer’ his sketch by using line commands in 2D or 3D CAD systems instead of using any particular sketching symbols.

Table 7. Preference of participants to use either *SKL1*, *SKL2*, both or none.

| Question | Frequency (expressed as %) | | | |
|---|----------------------------|------|------|------|
| | SKL1 | SKL2 | Both | None |
| Which sketching language do you prefer to use (if any)? | 26 | 58 | 7 | 9 |

6 Discussion and Conclusions

The research reported in this paper focused on the left side of Figure 2, i.e. on what designers want from a language, rather than on its relevance to automated processing. For instance, although the evaluators preferred *SKL2*, this language is far more complex to parse compared to *SKL1*, due to additional sectional symbols. However, as a proof-of-concept, *SKL1* has been already implemented in two prototype systems; one which generates 3D virtual models for processing on a Rapid Prototyping system [11] and another which proactively guides designers in generating right-first time form solution concepts [13] from paper-based sketches.

As future research work, both *SKL1* and *SKL2* need to be evaluated on a range of components, as the evaluation results presented in this paper are only indicative since they are based on just one component. Deeper investigation is also necessary to explore a suitable sketching medium for interfacing freehand sketching with CAD tools [3]. Related to this, it would be worth investigating whether designers only sketch in their design office or anywhere else to externalise their design concepts. A portable paper-based user-interface, which is based on a sketching language, would allow designers outside the design office to exchange design ideas between remote locations.

Although the sample of evaluators involved in this survey was not extensive, from the results obtained, it can be concluded that paper-based freehand sketching is still widely used during early design. The results also revealed that 42% of the participants were willing to accept a standard sketching language, provided that as a benefit a virtual 3D CAD model is automatically generated from a sketch. 49% replied "*not sure*", since they still have evaluate this approach concept in practice, rather to what they think of such an approach. However, independent of this, it was clear that for the majority of the evaluators the generation of a virtual CAD or a physical model from freehand sketches would be very useful during early design. Furthermore, as indicated by some participants, with a suitable sketching language, designers or indeed other users, would not need to be knowledgeable in using sophisticated 3D CAD systems to be able to generate virtual models. Thus the difficulty in capturing the paper representation of a design intent due to its ambiguity and hence the results obtained, collectively justify *why future CAD tools benefit from a sketching language* if they are to provide proactive support as from early design.

Acknowledgements

The authors are grateful for the contribution offered by all the evaluators who were involved in this survey. This research work has been funded by the University of Malta Research Grant entitled '*Knowledge Intensive Support*' (73374) and partially supported by the Italian National Council of Research under the '*Sportello del Mediterraneo*' initiative.

References

- [1] Pahl, Beitz, "Engineering Design", 2nd edition, Springer Verlag, 1996.
- [2] Borg, J. and MacCallum K. J., "A Life-Cycle Consequences Model Approach To The Design For Multi-X Of Components", Proceedings of ICED'97, Vol. 2, Tampere, Finland, 1997, pp. 647-652.
- [3] Roemer, A., Weibhahn G., Hacker W, Pache, M. and Lindemann U., "Effort-Saving product representations in design - results of a questionnaire survey", Design studies, Vol. 22, Issue 6, 2001, pp.473-491.
- [4] Lipson, H., "Computer-Aided 3D Sketching for Conceptual Design", Ph.D. Thesis, Israel Institute of Technology, Haifa, 1998.
- [5] Contero, M., Naya, F., Gomis J.M. and Conesa J., "Calligraphic Interfaces and Geometric Reconstruction", 12th ADM International Conference on Design Tools and Methods in Industrial Engineering, Rimini, Italia, 2001, pp. 110-117.
- [6] Pereira, J., Jorge, J., Branco V. and Nunes F., "Towards calligraphic interfaces: sketching 3D scenes with gestures and context icons", Proceedings of WSCG'2000 Conference, Plzen, Czech Republic, 2000.
- [7] Alvarado, C., Oltmans M., and Davis R., "A Framework for Multi-Domain Sketch Recognition", Technical Report of the AAAI Spring Symposium on Sketch Understanding, Stanford, California, 2002, pp. 1-8.
- [8] Lim, S., Duffy A. H. B. and Lim B.S., "Intelligent Computational Sketching Support for Conceptual Design", Proceedings of ICED '01, Glasgow, 2001, pp.453-460.
- [9] Andreasen, M.M., "Modelling - The Language of the Designer". Journal of Engineering Design, 1994. 5(2): pp. 103-115.
- [10] Mortensen, N.H. "Design Characteristics as Basis for Design Languages", Proceedings of ICED'97, Tampere, Finland, 1997, Vol. 2., pp.23-30.
- [11] Borg, J. C., Camilleri K.P., Farrugia P., Giannini F. and Muscat J., "'Sketch 3D Prototyping' For Aiding Conceptual Form Design", Proceedings of ICED'01 Conference, Glasgow, UK, 2001, Norway, 2002, pp.445-452.
- [12] Farrugia, P.J., "A sketching language based on survey results", Internal Report, Concurrent Engineering Research Unit, Department of Manufacturing Engineering, University of Malta, 2003.
- [13] Borg, J. C., P. J. Farrugia, Sciculna D. and Yan X.T., "'Paper Sketch' based 'Design for Multi-X'", Proceedings of NordDesign 2002 Conference, Trondheim, Norway, 2002, pp.17-24.

Corresponding author:

Dr. Ing. Jonathan C. Borg
Department of Manufacturing Engineering
Faculty of Engineering
University of Malta
Msida, MSD06
Malta
Tel:+356 2340-2366
Fax: +356 21 343577
E-mail: jjborg@eng.um.edu.mt