

Performance assessment of domestic photovoltaic power plant with a storage system

Ferdinando Chiacchio*, Diego D'Urso*, Jose Ignazio Aizpurua**, Lucio Compagno*

*Dipartimento di Elettrica, Elettronica ed Informatica, Università degli Studi di Catania, Italy

** Department of Electronic and Electrical Engineering, University of Strathclyde, Scotland

Abstract: Grid-connected low voltage photovoltaic power plants cover the majority of the power capacity installed in Italy. They offer an important contribution to the power demand of the utilities connected but, due to the nature of the solar resource, the night time consumption can be satisfied only withdrawing the energy by the national grid, at the price of the energy distributor. Thanks to the improvement of storage technologies and the decreasing of costs, the installation of a system of battery looks a promising solution. In this paper, a model-based approach to analyze and discuss the performance of a domestic photovoltaic power plant with a storage system is presented.

Keywords: Dynamic Reliability, Monte Carlo Simulation, Service Availability, Retrofit Photovoltaic Power Plant,

1. INTRODUCTION

In the last decades, the renewable energy industry has grown unceasingly. Nowadays, small, decentralized, photovoltaic power plants play a key role in the sustainable development of distributed generation as a major alternative of energy provision in remote locations where the electrical grid cannot be reached. Whereas the feasibility analysis of medium and high voltage photovoltaic power plants can be very complex, low voltage systems are characterized by a great simplicity of design, installation and operation. For these reasons, their diffusion has strongly increased in these last years, supported also by government incentive policies (GSE, 2011). To give an idea in numbers, between the 2010 and the 2016, in Italy the number of low voltage (LV) photovoltaic power plants with a capacity comprised in the range 1~20kW has grown from 140k to 700k units, that sum up to 3.1GW of PV capacity (GSE, 2016).

The majority of the LV photovoltaic power plants are made up by fixed arrays of solar panels. For instance, in domestic applications it became common the installation of retrofit systems: photovoltaic power plants mounted on the roof of buildings that, connected to the electrical grid, follow a simple production schema as shown in Figure 1.

The DC/AC inverter (2) converts the direct current power $P_{DC}(t)$ into an alternate current power $P_{AC}(t)$ that is measured by a production meter (3). The bidirectional meter (4) counts the power exchanged by the power plant and the electrical grid (5) so that it is possible to identify an outgoing (to the electrical grid) $P_{OUT}(t)$ and an ingoing (to the utilities) $P_{IN}(t)$ power. The former case is when the instantaneous power demand required by the utilities of the building $P_B(t)$ is lower than the power $P_{AC}(t)$ provided by the power plant, so that the difference $P_{OUT}(t) = P_{AC}(t) - P_B(t)$ is transferred to the national electrical grid (5). The latter case is when the $P_B(t)$ is

greater than $P_{AC}(t)$, so that the missing power to allow a proper functioning of the utilities is provided by the national electrical grid, $P_{IN}(t) = P_B(t) - P_{AC}(t)$.

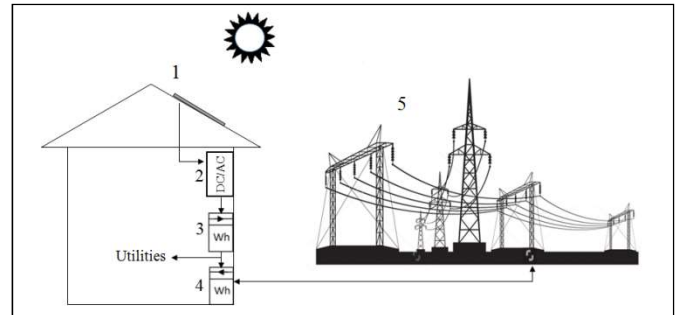

Fig. 1. Production schema of a domestic photovoltaic power plant

As already mentioned, several independent power plants (700k units in 2016) are currently connected to the electrical grid. Therefore, it is possible to consider the national electrical grid as a huge battery with an infinite capacity able to collect the exceeding energy not instantaneously used by the utilities and to supply the required energy to the utilities when the power plant production cannot cover the instantaneous power demand. Nevertheless, two main issues have arisen in these last years: the instability of the electrical power grid, unable to manage the power fluctuations of this increasing number of photovoltaic power plants connected; and the incapability of these systems to store the energy not instantaneously consumed. To tackle the previous issues, a possible solution is the integration of a storage systems: large power plants can use the batteries so as to control the fluctuations of the power output, whereas small power plants can benefit of the storage capacity in order to compensate the shortage of energy when the utilities demand exceeds the one

instantaneously produced by the power plant. In this paper, the focus is targeted on small power plants and this study aims to evaluate how the installation of a battery can affect the performance of the system in terms of plant and service availability. The main motivation for targeting the study to the small power plants is that this class of systems is the most diffused (i.e., in Italy it covers the 88% of the total capacity installed). In particular, for domestic retrofit power plants, the integration of the battery has an important impact in terms of installation costs that can be justified when the increasing of service availability is relevant. For this reason, an ad-hoc study addressing the benefits and drawbacks of such solution can be of great interest. The methodology adopted in this paper makes use of a model-based approach with a dynamic reliability analysis. To this end, the model of a retrofit photovoltaic power plant is designed using the Stochastic Hybrid Fault Tree Automaton (SHyFTA) formalism (Chiacchio et al, 2016), a novel technique of dynamic reliability that allows a modular definition of the system model in terms of its characteristic physical and stochastic processes.

The rest of this paper is organized as follows. Section 2 describes the basic concepts of the SHyFTA modelling including a brief overview of the state-of-the-art approaches currently available. Section 3 describes the case study and the SHyFTA model, whereas Section 4 presents the results of the simulation. Finally, Section 5 summarizes conclusions and discusses future works.

2. DYNAMIC RELIABILITY MODELLING WITH STOCHASTIC HYBRID FAULT TREE AUTOMATON

Dynamic reliability defines a mathematical framework able to combine deterministic (e.g., process of energy transformation) and stochastic (e.g., process of failure of a system) models. In this way, it leads to a more accurate reliability modelling able to account for environmental and operational changes of the working conditions.

Literature presents several contributions that address the modelling of the deterministic and the stochastic processes characterizing an engineering system. For instance, the design and the study of renewable power plants with deterministic approaches are object of several academic courses and handbooks (Patel, 2014). Iversen et al., (2014) proposed an analytical model to forecast the solar irradiance, whereas Iqbal et al. (2014) and Mellit et al. (2014) present data-driven statistical learning methods to predict the effects of the renewable resources onto the power plants operations. In a previous work, Chiacchio et al. (2018) analyzed the performance of photovoltaic power plant using a SHyFTA model, but they did not use this modelling technique to evaluate the service availability of the system.

Availability is the one of the main attribute of reliability engineering study and it can be evaluated by the mean of a stochastic model, like Fault Tree and others. But, the only availability cannot be used to achieve an accurate modelling of the system performance because these techniques do not account for the dynamic variations of the physics of a system.

Dynamic reliability studies the behavior of a complex system by adopting a model-based approach. This implies dealing

with the thermodynamic equations to specify physical processes that have an influence on the health of system components: on the one hand, it requires the definition of the stochastic differential equations of the process and, on the other hand, it enables forecasting performances and failures while boundaries conditions and independent variables can vary. Among the possible modelling techniques of dynamic reliability, SHyFTA is one of the most interesting as it allows an extensible modelling and a simple definition of reward functions (Trivedi et al., 1994) for the performance evaluation and feasibility assessment of a system. In this way it is possible to compute several dependability attributes like reliability or availability as well as important design-related key performance indexes, such as the service availability and the productivity of a system. Moreover, a SHyFTA model can be coded and simulated with a general-purpose programming language (like python, Java, C, etc.) or implemented with a high-level programming language like Matlab. The mathematical formulation of SHyFTA is presented in (Chiacchio et al, 2016), therefore interested readers can refer to that paper for more information.

To develop a SHyFTA model for an engineering system, a methodology based on six steps can be followed, as shown in Figure 2.

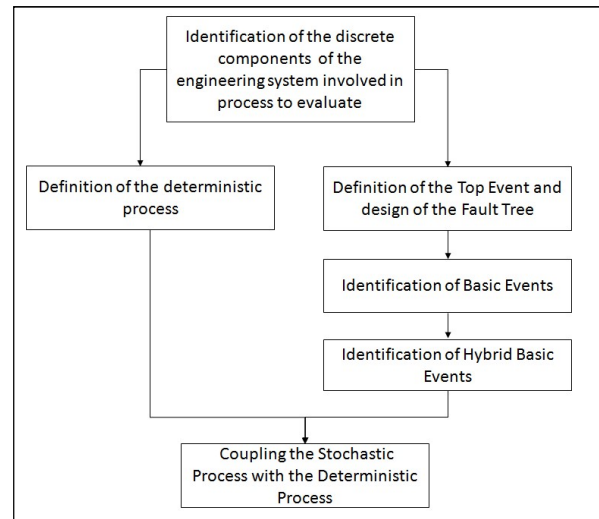

Fig. 2. Steps to build up a SHyFTA model

The first step consists in the identification of the discrete components of the engineering system involved in the process under analysis. These components take part in both the deterministic and the stochastic processes of the SHyFTA model. As for the former (see the left branch of the flow chart in Figure 2), the mathematical equations that describe the physical process performed by the system components must be defined. As for the latter (see the right branch of the flow chart in Figure 2), the SHyFTA requires the definition of the fault tree model having as Top Event the failure of the process under analysis. The Basic Events (BEs) of the Fault Tree represent the failure behaviour of the components of the engineering system. The BEs are characterized by a static probability distribution of the time to fail (pdf), generally provided by the component manufacturer that specify the mean time to fail (MTTF) when the system operates within

its nominal working conditions. But, in a SHyFTA model it is possible to define a more powerful type of basic events, called Hybrid Basic Events (HBE) characterized by a variable probability distribution function. The HBEs can be used for those components for which the relationships between the failure behaviour and the system conditions are known. In these cases, the HBE must be defined with a set of different probability distribution functions on the basis of the different operating conditions in which a system can operate; or with a functional $F(\cdot, t)$ variable in its parameters. In this latter case, the parameters of the functional F vary with a change of the working conditions.

The formulation of the SHyFTA is completed when the stochastic and the deterministic models are coupled through shared variables. Namely, the physical variables that affect the operating conditions of a component (modifying the pdf of a HBE) are synchronized in the fault tree model. On the other hand, the events occurring in the stochastic model, like the failure of a component are transferred to the deterministic model. In this way, the contribution of the failed component is nullified in the physical process of the deterministic model (e.g., an inverter that fails will no longer output AC power).

An important feature of dynamic reliability models is the aging (Manno et al., 2013). Aging characterizes the wearing-out of complex electro-mechanical equipment, whose performance degrades in time during the lifetime. In a SHyFTA model, the aging effect can be modelled using a functional described with a Weibull pdf, characterized by a shape factor $\beta > 1$ (i.e., the failure rate is increasing with respect to time) and a scale parameter γ defining the non-constant failure rate $\lambda(t)$ as follows:

$$\lambda(t) = \beta/\gamma \times (t/\gamma)^{\beta-1} \quad (1)$$

The variable t is not linear but it can be described by a piecewise deterministic Markov process (Manno et al., 2013), using the following ordinary differential equation:

$$\frac{dL}{dt} = i_{on} \quad (2)$$

$$i_{on} = \begin{cases} 1, & \text{component ON} \\ 0, & \text{component OFF} \end{cases}$$

3. CASE STUDY: A PHOTOVOLTAIC POWER PLANT UNDER THE NET METERING REGIME

Starting from January 2009, the Italian Government has emanated a regulation, called *Scambio sul Posto* (Net Metering), which disciplines the rules for the connection of a photovoltaic power plant with the national electrical grid (GSE, 2011). Together with the incentive decree of the Conto Energia, this regulation has favoured the diffusion of small (<20 kW) power plants since it simplified the process of installation and management of the energy produced and dispatched to the electrical grid. With this mechanism, the *Gestore dei Servizi Energetici* (GSE), the Italian authority for the regulation and supervision of the renewable energy market in Italy, can manage and track the flows of energy produced by the photovoltaic power plants. Adhering to the Net Metering, the owner of a power plant allows the GSE to sell the energy not instantaneously consumed by its utilities

to the energy market; the income is then accounted to obtain a reduction of the electric bill for all the duration of the plant life. Recently, the regulation of Net Metering has been modified to rule the installation of storage systems for those power plants that are already connected to the electrical grid. This innovation changes drastically the benefits of the plant owners because by storing the energy during the day when the plant produces, this energy becomes available in the evening and in the night, when the plant does not produce and there are highest domestic electricity consumptions. Therefore, it is important to determine the overall benefit that can be achieved with the installation of a storage system.

Figure 3 shows a schematic decomposition of a photovoltaic power plant with a single inverter and a battery, a very common case for small domestic power plants. It is possible to identify the system blocks of the PV Generator and of Grid Connection Coupling. The former is constituted by all the active elements of the photovoltaic power plants that realize the energy conversion, whereas the latter allows the connection with the electrical grid realizing a parallel coupling with the power plant generator in the differential circuit breaker component (DCB).

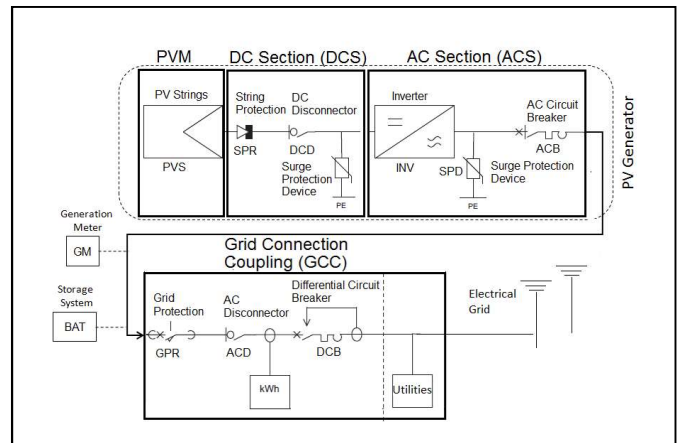

Fig. 3. Schematic decomposition of the PV system

3.1 Energetic consumption

It can be assumed that the average yearly energetic consumption for a domestic contract with a connection capacity of 4.5 kW is resumed in Table 1.

Table 1. Average yearly consumption (4.5 kW contract)

Source of Consumption	Average (kWh)
Lighting	430
Electrical Kitchen	530
Refrigerator with Freezer	1000
Washing Machine	250
Dryer	370
Dishwasher	350
Television, Audio/Video Equipment	320
Other electrical devices	440
Air Conditioning systems	500

With these values, it is possible to model the generic power demand during an ordinary day of summer and an ordinary

day of winter and spring, assuming that the energetic consumption in summer time is greater due to the use of the Air Conditioning systems, as shown in Figure 4 and Figure 5.

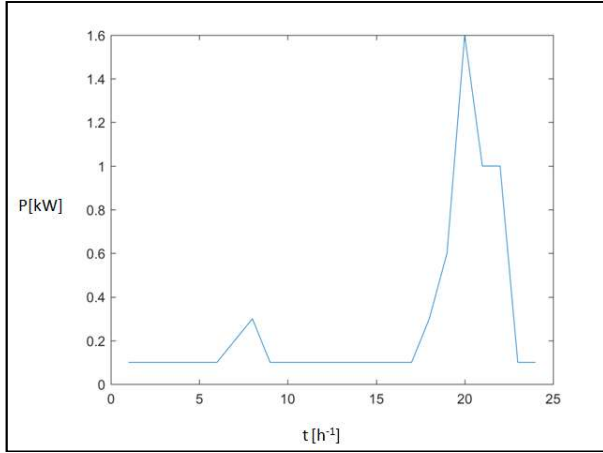

Fig. 4. Mean energetic consumption in winter and autumn

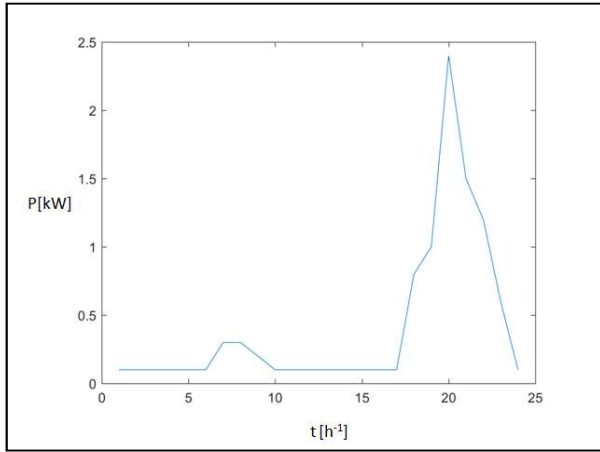

Fig. 5. Mean energetic consumption in spring and summer

3.2 Characteristics of a retrofit small power plant

For this case study, it is assumed that the power plant is installed in the roof of a house located nearby Catania at the following coordinates: 37.555728 N, 15.135651 E.

Table 2-4 show respectively the main characteristics of the power plant object of this case study.

Table 2. PV system characteristics.

P_{peak}	4.32 kW
N. Inverters	1
N. Panels	18
N. Strings	2
Azimuth Angle	180°
Tilt Angle	24° (Fixed on the roof)
P_{peak}	240 W (Monocrystalline)
Panel efficiency	19%

The power plant is characterized by a peak power, $P_{peak} = 4.32kW_p$ and by a DC/AC inverter of nominal power of 4.2 kW. There are 2 strings composed by 9 photovoltaic modules

connected to the two independent MPPT input of the inverter. The battery can be coupled to the power plant at the end of the AC Section. The charge/discharge power supported is of 5kW and the maximum amount of energy storable is 13.2 kWh.

Next the steps discussed in Figure 2 are applied to build up the SHyFTA model of the power plant of Figure 3.

Table 3. PV inverter main characteristics.

P_{NOM}	4.2 kW
P_{ACMax}	4.6 kW
Voltage Range (MPPT)	140-530 V
N. Independent MPPT	2
Warranty	5 years

Table 4. Storage system characteristics.

AC_{Energy}	13.2 kWh
AC Voltage	120/240 V
$P_{ACMax}(\text{charge/discharge})$	5 kW
Depth of Discharge	100%
Round Trip Efficiency	89%
Warranty	10 years

3.3 Definition of the Deterministic Process

In Chiacchio et al. (2018), the mathematical formulation of the deterministic process is presented, therefore in this section the main equations used in the SHyFTA model are recalled.

The photovoltaic conversion starts at the PVM stage where PV modules capture the solar irradiance that is converted into a DC power. The electrical power generated with the configuration of panels installed in the roof, having a fixed tilt and orientation (Azimuth), can be defined as follows:

$$P = \eta I_o \sin(\alpha) S \quad (3)$$

where I_o is the orthogonal solar irradiance to the direction of solar radiation [W/m^2]; α is the angle of the module/string with respect to the incident solar radiation; S is the area of the module [m^2]; and η is the system efficiency (always less than 1). At the PVM stage, meteorological factors (e.g., wind speed, cloud transients in PV units, incident irradiance or ambient temperature) or yearly deterioration can reduce the efficiency of the photovoltaic modules that can be computed considering the variation of the temperature:

$$\eta_m = \eta_{std} [1 - \rho (T_c - T_{c,std})] \quad (4)$$

where η_{std} and $T_{c,std}$ are respectively the efficiency and the module temperature at standard conditions, ρ is the power coefficient (percentage variation of power for 1°C) and T_c is the module temperature. In this deterministic process, the input variables to the model must be the module temperature T_c and the sun irradiation I_o .

The performance degradation occurring in the PVM stage reduces the DC power, but does not stop the power production unless the DC breakers and disconnectors of the DCS stage interrupt the circuit or the cables fail. In fact, with reference to Figure 3, a single PV generator can contribute to the power generation of the system if the circuit path from the

PVM stage to the GCC is closed. Before connecting to the grid, the DC current is converted into alternating current. The DC/AC inverter of the AC section performs this transformation with an efficiency that depends on the input load:

$$\eta_{\text{inverter}} = \frac{P(t)_{\text{AC}}}{P(t)_{\text{DC}}} = 1 - \frac{P_{\text{loss}}}{P(t)_{\text{DC}}} \quad (5)$$

To compute the energy produced and measured by the generation meter (GM) before the GCC stage it is possible to integrate the P_{AC} in the time interval $[t_2, t_1]$:

$$E_{\text{PROD}}(t) = \int_{t_1}^{t_2} P_{\text{AC}}(t) dt \quad (6)$$

The battery is charged if the power produced is not instantaneously consumed by the utilities connected to the power plant. Therefore, it is possible to write the equation:

$$P_{\text{BAT}}(t) = P_{\text{AC}}(t) - P_{\text{CONS}}(t) \quad (7)$$

When P_{BAT} is negative, it means that the power plant is not able to satisfy the demand of power for the utilities connected, therefore if the battery has charge it contributes to the domestic power supply. Conversely, when P_{BAT} is positive the power produced by the power plant is used to charge the battery as long the storage capability is reached; otherwise it is injected to the national electrical grid.

The other components involved in a photovoltaic system are protection, cables, breakers, disconnectors and transformers. All these components play an important role in the energy production because if one of them interrupts the circuit path to the GCC, the PV generator in the open path cannot contribute to the power generation. This is a very critical aspect of the production process, in particular when considering the elements of the GCC stage. In fact, if one of the components of the GCC stage interrupts the circuit path, all the power plant stops the production because it gets disconnected from the national grid, causing the complete system unavailability. To determine the impact of these circumstances to all the production process the stochastic fault tree model has to be designed and linked to the deterministic model.

3.4 Definition of the Stochastic Process

The fault tree model in Figure 6 describes the failure behavior of the plant.

Table 5. PV inverter main characteristics.

Component	λ : Failure Rate [h^{-1}]	μ : Repair Rate [h^{-1}]
ACB	5.71×10^{-6}	8.3×10^{-4}
ACD	0.034×10^{-6}	8.3×10^{-4}
DCB	5.71×10^{-6}	8.3×10^{-4}
GPR	5.71×10^{-6}	8.3×10^{-4}
PVP	2.43×10^{-5}	8.3×10^{-4}
SPR	0.313×10^{-6}	8.3×10^{-4}
SPD/SDP	0.313×10^{-6}	8.3×10^{-4}
INV	Aging Weibull	1.9×10^{-4}
BAT	Aging Weibull	1.9×10^{-4}

The failure/repair rates (Chiacchio et al., 2018) of the components are shown in Table 5. It is assumed that components can be only in two possible statuses. Therefore, it is possible to set the binary representation of the components health as follows:

$$S_{BEi} = \begin{cases} 1, & i^{\text{th}} \text{ component is working} \\ 0, & i^{\text{th}} \text{ component is failed} \end{cases} \quad (8)$$

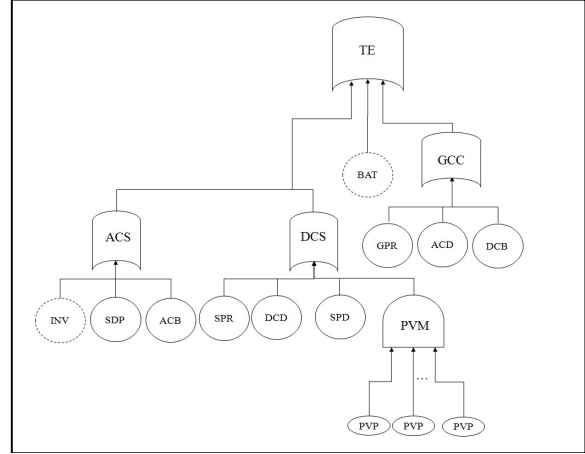

Fig. 6. Fault Tree of the retrofit PV system with the battery

Note that the inverter and the battery have been modelled as a hybrid basic event using a Weibull pdf that depends on the aging variable. For the inverter, the failure rate is bounded to the solar radiation input because an inverter stops working when the solar irradiation is low or absent (e.g. during the night time). For the battery, the aging increases during the charging and discharging phase. As for repair rates, it was assumed that electrical components like breakers, disconnectors, string box and protection can be restored to as-good-as-new within a working week after a fault. For the battery and the inverters it was assumed a longer period of restoration considering that these components should be sent to the assistance and take around three weeks to be restored.

4. SIMULATIONS AND RESULTS

The SHyFTA was simulated for a mission time of 8760 hours corresponding to a year of activity. The sun irradiation and the temperatures measured at the site location for the year 2016 have been used as inputs of the deterministic process of the SHyFTA model. It was set a confidence level of 0.95 on the estimator of the energy E_{AC} , output of the power plant. Figure 7 shows the energy E_{AC} produced by the power plant and measured at the generation meter. It sums up to 6350 kWh that is close to the expected power computed with a simple deterministic calculation, considering the average irradiation I_{avg} for the location (1500 kWh/kWp) and the peak power P_p of the power plant (4.32 kW), $E_{\text{AC}/\text{det}} = P_p \times I_{\text{avg}} = 6480$ kWh. More interesting are the results of the service availability computed before and after the installation of the storage system. The service availability (SA) is defined as the ratio between the sum of the time intervals in which the power supply of the system (power plant and battery) is able to cover the power demand of the domestic utilities over the total time in which the utilities are under consumption:

$$SA = \frac{\sum_i T_{\text{system supply}}}{\sum_i T_{\text{system supply}} + \sum_j T_{\text{external supply}}} \quad (9)$$

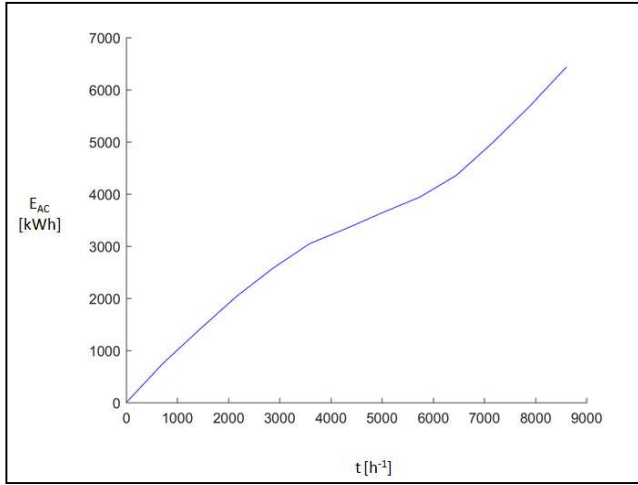

Fig. 7. Fault Tree of the retrofit PV system with the battery

To evaluate this performance index, it is possible to use the daily trends shown in Figure 4 and Figure 5 to model the energetic consumption throughout the 8760 hours of the year. The results of the simulation show that without the storage system, the service availability is 38%. This means that the 62% of the energy consumed by the plant owner has to be purchased from the electricity distributor. Conversely, with the integration of a battery, the service availability increases up to the 98%. It is possible to compute the yearly energy consumption E_{cons} as the sum of each entry of Table 1 and evaluate the cost of the yearly bill, $\text{Bill}_{\text{year}}$, assuming an average price, C_{kWh} , of 0.2€/kWh with the formula:

$$\text{Bill}_{\text{year}} = (1 - SA) \times E_{\text{cons}} \times C_{\text{kWh}} \quad (10)$$

The total economic benefit must consider also the income realized with the sale of the energy not consumed by the GSE that can be subtracted from the yearly bill. Considering an average selling price, S_{kWh} , of 0.07€/kWh and using the following formula, the yearly income can be computed:

$$\text{Income}_{\text{year}} = [E_{\text{AC}} - (SA \times E_{\text{cons}})] \times S_{\text{kWh}} \quad (11)$$

Table 6 shows the comparisons between the two systems. It is possible to notice that the storage system brings an overall income for the owner plant of about 140€/year, while the power plant without storage ends up with a yearly cost of about 186 € that can be subjected to the increase applied by the distributor. Finally, the power plant availability can be computed solving the fault tree model of Figure 4. Results show that the power plant without storage system has an availability of 99.9% that decreases to 98.5% when the storage system is installed.

5. CONCLUSIONS

In this paper, an application of the SHyFTA modelling was designed to evaluate the performance of a retrofit domestic

power plant with a battery. The interest for this type of application relies on the recent regulation emitted by the Italian Government that allows the integration of the storage systems for these type of renewable power plants. The SHyFTA model has been used to compute the energy production of the power plant object of the case of study and the service and the plant availability with and without the storage system. It was interesting to notice that the service availability increases substantially with the integration of the battery, although this decreases the plant availability. Moreover, the battery can profit an extra-income to the plant owner due to the savings achieved on the yearly bill.

Table 6. PV inverter main characteristics.

Storage	SA	Bill _{year}	Income _{year}
No	38%	520 €	334€
Yes	98%	17€	157 €

REFERENCES

- Chiacchio, F., D'Urso, D., Compagno, L., Pennisi, M., Pappalardo, F. and Manno, G. (2016a). SHyFTA, a Stochastic Hybrid Fault Tree Automaton for the modelling and simulation of dynamic reliability problems. *Expert Systems with Applications*, 47: 42–57.
- Chiacchio F., Famoso F., D'Urso D., Brusca S., Aizpurua JI and Cedola L. (2018). Dynamic Performance Evaluation of Photovoltaic Power Plant by Stochastic Hybrid Fault Tree Automaton Model. *Energies*, 11(2), 306; doi:10.3390/en11020306
- GSE (2011). Il Terzo Conto Energia, Guida alla richiesta degli incentivi per gli impianti fotovoltaici.
- GSE (2016). Rapporto Statistico sul Solare Fotovoltaico.
- Iqbal, M., Azam, M., Naeem, M., Khwaja, A.S. and Anpalagan, A. (2014). Optimization classification, algorithms and tools for renewable energy: A review. *Renewable and Sustainable Energy Reviews*, Volume 39: 640–654.
- Iversen, E.B., Morales J.M., Møller J.K. and Madsen, H. (2014). Probabilistic forecasts of solar irradiance using stochastic differential equations. *Environmetrics*, Volume 25, Issue 3, pp: 152–164.
- Manno, G., Zymaris A., Kakalis, NPM, Chiacchio, F., Cipollone FE, Compagno L., D'Urso D. and Trapani N. (2013). Dynamic reliability analysis of three nonlinear aging components with different failure modes characteristics. *Safety, Reliability and Risk Analysis: Beyond the Horizon - Proceedings of the European Safety and Reliability Conference, ESREL 2013*.
- Mellit, A., Sağlam, S. and Kalogirou, S.A. (2013). Artificial neural network-based model for estimating the produced power of a photovoltaic module. *Renewable Energy*, Volume 60:71–78.
- Patel, M.R. (2015). *Wind and Solar Power Systems: Design, Analysis, and Operation*, CRC Press, Taylor & Francis, ISBN 978-0849315701.
- Trivedi, K.S., Malhotra, M. and Fricks, R.M. (1994). Markov reward approach to performability and reliability analysis, *Proceedings of the Second International Workshop on Modeling, Analysis, and Simulation of Computer and Telecommunication Systems*.