

1           **TIME TO SURFACE CRACKING AND CRACK WIDTH OF REINFORCED**  
2           **CONCRETE STRUCTURES UNDER CORROSION OF MULTIPLE REBARS**

3  
4                                   Xun Xi<sup>1,2</sup> and Shangtong Yang<sup>2\*</sup>

5           <sup>1</sup> *School of Civil and Resource Engineering, University of Science and Technology Beijing, Beijing,*  
6           *100083, China.*

7           <sup>2</sup> *Department of Civil and Environmental Engineering, University of Strathclyde, Glasgow, G1 1XJ,*  
8           *United Kingdom.*

9  
10           **ABSTRACT**

11           Concrete cover cracking caused by corrosion of reinforcement is one of major deterioration  
12           mechanisms for reinforced concrete structures. In practice, time to surface cracking and crack  
13           width evolution are of significance in regards to the assessment of serviceability of reinforced  
14           concrete structures. Literature review suggests that, although considerable research has been  
15           undertaken on corrosion-induced concrete cracking, little has been focused on corrosion of  
16           multiple reinforcing bars, especially by considering the non-uniform corrosion process. In this  
17           paper, a time-dependent non-uniform corrosion model is established. A cohesive crack model  
18           is then formulated to simulate arbitrary cracking in the whole cover of concrete structures.  
19           Two typical cover failure modes (i.e., “delamination” and “combined delamination and corner  
20           spalling”) have been simulated under the non-uniform corrosion of multiple reinforcing bars  
21           and found dependent on spacing of reinforcement and fracture energy of concrete. The effects  
22           of corrosion, geometric and mechanical parameters on the time to surface cracking after  
23           corrosion initiation and the crack width evolution are also investigated and discussed. The  
24           developed model is partially verified by comparing the results with those from experimental  
25           tests on uniform corrosion of multiple reinforcing bars.

26           **Keywords:** corrosion initiation, surface cracking, non-uniform corrosion, multiple reinforcing  
27           bars, cohesive crack model, reinforced concrete, finite element modelling.

28           \* Corresponding author. Tel: +44 141 548 3273. Email: shangtong.yang@strath.ac.uk.

## 29 1 INTRODUCTION

30 Corrosion of reinforcement is a significant problem affecting the durability of reinforced  
31 concrete (RC) structures, e.g., bridge decks, retaining walls, piers, tunnels. Practical  
32 experience and observations suggest that corrosion-affected RC structures are more prone to  
33 cracking than other forms of structural deterioration. Consequently, the corrosion induced  
34 cracks destroys the integrity of the concrete cover, deteriorate the bonding strength of the  
35 interface between reinforcement and concrete, and lead to premature failure of RC structures.  
36 Moreover, the reinstatement cost of corrosion-affected RC structures is significantly high;  
37 worldwide, the maintenance and repair costs for corrosion-affected concrete infrastructure are  
38 estimated around \$100 billion per annum [1].

39

40 Considerable research has been carried out in concrete cover cracking induced by corrosion of  
41 reinforcement [1-8]. Liu and Weyers [2] were amongst the first to model the surface cracking  
42 time of concrete cover due to corrosion of reinforcement, based on a series of experimental  
43 tests. Their formula for the critical amount of corrosion products has been widely cited in the  
44 research literature. Pantazopoulou and Papoulia [4] established a relationship between the  
45 amount of corrosion products and internal pressure from which the cracking time of the  
46 concrete cover can be obtained. Li *et al.* [9] developed an analytical model to calculate the  
47 crack width of concrete cover caused by corrosion of reinforcement. Amongst these existing  
48 studies, most are focused on uniform corrosion of a single reinforcing bar.

49

50 However, due to the fact that chlorides, as well as moisture and oxygen, penetrates into  
51 surface of steel at different rates on different sides of the concrete, it is rare to have a uniform  
52 corrosion on the reinforcing bar. Recently, some researchers have started to model the  
53 cracking of concrete cover induced by non-uniform corrosion. According to geometry and

54 diffusion properties of concrete, non-uniform corrosion model can be built by considering  
55 chloride concentration via Fick's second law of diffusion [10-12]. However, the actual  
56 environmental conditions of concrete may differ significantly from the hypothesis under  
57 Fick's law [13]. Meanwhile, experimental tests or field surveys have been carried out to  
58 determine the distribution of corrosion rust which is found not uniform along the  
59 circumference of the reinforcement [14-16]. Almost all the experimental results in literature  
60 have shown that only the part of reinforcement facing concrete cover is corroded and the  
61 further towards the concrete surface the location is, the more corrosion products that are  
62 produced at this location. Some studies introduced a factor defining the ratio of the depth of  
63 non-uniform corrosion to that of uniform corrosion, and found that its value ranges about 4-8  
64 in natural conditions [17-19]. Yuan and Ji [16] conducted corrosion tests on reinforced  
65 concrete samples in an artificial environmental chamber and found that, only a half of the  
66 reinforcement, facing concrete cover, was corroded and the expansion was in a semi-elliptical  
67 shape. Similar corrosion distributions were also found in other experiments [20].

68  
69 Moreover, corrosion rate is the most important single parameter controlling the corrosion  
70 development [2, 9, 21, 22]. Previous work on predicting of corrosion-induced cover cracking  
71 mainly assumes a constant mean annual value of corrosion rate for the whole life-cycle of RC  
72 structures after corrosion initiation [18, 19, 23]. However, the corrosion process of steel  
73 reinforcing bar is an electrochemical reaction process influenced by three factors, i.e.,  
74 chloride concentration, oxygen content and resistivity of concrete [24]. In natural  
75 environment, the actual corrosion rate should change throughout the year and the full life-  
76 cycle of RC structures. A number of researches have been made to analytically establish the  
77 corrosion rate model for the entire lifetime of RC structures based on the electrochemical  
78 theory and/or to conduct experiments under artificial and nature climate environment  
79 conditions for verifications [25-28].

80

81 Under the expansive force caused by non-uniform corrosion of reinforcement, concrete cover  
82 can be cracked which leads to delamination of the cover. To investigate the structural effects  
83 of corrosion on the concrete cover, most previous work is focused on a single reinforcing bar,  
84 e.g., in [11, 18, 29]. It has been proved that the location of rebar (i.e., corner and middle  
85 rebars, respectively) and boundary conditions have significant effect on cover cracking  
86 induced by reinforcement corrosion [11, 29]. Moreover, spacing between the reinforcement,  
87 in case of multiple reinforcing bars, can influence the stress fields and thus the time to surface  
88 cracking and the cracking patterns. Very few of the existing models can well explain the  
89 effect of corrosion of multiple rebars on cracking of the whole concrete cover, including those  
90 of uniform corrosion [30]. Amongst the limited studies on corrosion of multiple rebars, Chen  
91 et.al [19] simulated the crack patterns of concrete cover induced by uniform corrosion of two  
92 reinforcing bars via lattice model. Further, Zhang et.al [31] modelled the cover cracking of  
93 RC structures with two reinforcing (middle) bars under non-uniform corrosion via damage  
94 plastic model. Literature review suggest that very little work has been carried out on cover  
95 cracking induced by non-uniform corrosion of multiple reinforcing bars of RC structures and;  
96 the relationship between the cover cracking and the time-dependent corrosion rate of the  
97 whole life-cycle under corrosion of multiple reinforcing bars has not been established.

98

99 This paper attempts to develop a combined analytical and numerical method to predict the  
100 time to cover cracking after corrosion initiation and the crack width under time-dependent  
101 non-uniform corrosion of multiple reinforcing bars of RC structures. A non-uniform corrosion  
102 model is first formulated based on available experiment results. The time-dependent corrosion  
103 rate in the whole life-cycle of RC structures is introduced. Under the expansion caused by  
104 corrosion of multiple reinforcing bars, arbitrary discrete cracks are modelled in cover concrete  
105 by cohesive elements with finite element method. Time to concrete cracking, crack width and

106 crack patterns of the whole cover are obtained. The developed model is partially verified by  
107 comparing the results of uniform corrosion from the developed method and experiments, due  
108 to the lack of experimental data on non-uniform corrosion. Moreover, a parametric study is  
109 carried out to investigate the effects of some key parameters, e.g., fracture energy of concrete,  
110 spacing between the reinforcing bars and corrosion rate, on the time to surface cracking and  
111 crack width, under non-uniform corrosion of multiple reinforcing bars.

112

## 113 **2 RESEARCH SIGNIFICANCE**

114 Considerable research has been conducted in the last few decades in modelling corrosion of  
115 reinforcement in concrete and its effects on concrete cover cracking. However, most of  
116 existing studies are focused on corrosion of a single reinforcing bar and model the cover  
117 cracking as a thick-wall cylinder (mainly analytical) or other geometries (mainly numerical).  
118 Very few models could address the interactive behaviour of corrosion of multiple reinforcing  
119 bars of RC structures, e.g., beams with 4 tensile rebars. In fact, the cover cracking patterns,  
120 time to surface cracking and crack width development could be significantly affected by the  
121 combined stress fields generated from corrosion of multiple steel bars. Therefore, a rational  
122 model for predicting concrete cover cracking should employ a system approach, by  
123 considering all corrosion-affected reinforcing bars, rather than a simplified approach by  
124 simulating a single bar only. Moreover, corrosion is actually a time-dependent process and  
125 non-uniform along the circumference of reinforcing bars. It would be ideal to derive a time-  
126 dependent non-uniform corrosion model for failure prediction of the whole cover of RC  
127 structures with multiple reinforcing bars. It is in this regard this paper is presented.

## 128 **3 TIME-DEPENDENT NON-UNIFORM CORROSION**

129 Chloride-induced corrosion of reinforcing bar in concrete produces rusts (mainly ferrous and  
130 ferric hydroxides,  $Fe(OH)_2$  and  $Fe(OH)_3$ ) which accumulate and result in cracking, spalling

131 and delamination of RC structures. The corrosion rusts first fill in the annular porous layer in  
 132 concrete around the reinforcing bar, often referred to “diffusion zone” or “porous zone”. This  
 133 initial stage normally does not produce stresses in concrete. As schematically shown in Figure  
 134 1,  $D$  is the diameter of the bar and  $d_0$  is thickness of the “porous zone”. The thickness  $d_0$   
 135 varies from 10 to 20  $\mu\text{m}$  according to the porosity of concrete and compaction degree, which  
 136 is constant once concrete has hardened [23]. Depending on the level of corrosion, the products  
 137 of corrosion may occupy up to a few times more volume than the original steel. As corrosion  
 138 of the reinforcement propagate further, a band of corrosion products forms, as shown in  
 139 Figure 1. If corrosion process is assumed uniform, the band becomes a circular ring which  
 140 causes uniform stresses in the concrete. However, due to the fact that the chlorides, as well as  
 141 moisture and oxygen, reach the reinforcement surface at different rates through top side of the  
 142 concrete structure, it is rare to have uniform corrosion around the reinforcement. Experiments  
 143 results suggest that the front of corrosion products for the half of rebar facing concrete cover  
 144 is in a semi-elliptical shape, while corrosion of the opposite half of rebar is negligibly small  
 145 [16].

146  
 147  
 148 As illustrated in Figure 1(b), the total amount of corrosion products  $W_{rust}$  can be assumed to  
 149 occupy three bands: the semi-elliptical band of corroded steel with maximum thickness  $d_{co-st}$ ,  
 150 the porous circular band  $d_0$  and the semi-elliptical rust band with maximum thickness  $d_m$ .  
 151 The semi-major axis and semi-minor axis for the semi-ellipse of corrosion front are  
 152  $D/2 + d_0 + d_m$  and  $D/2 + d_0$ , respectively.

153  
 154 Based on the geometry, the total amount of corrosion products  $W_{rust}$  can be shown as follows:

$$155 \quad \frac{2W_{rust}}{\pi} \left( \frac{1}{\rho_{rust}} - \frac{\alpha_{rust}}{\rho_{st}} \right) = Dd_0 + d_0^2 + \frac{D}{2}d_m + d_0d_m \quad (1)$$

156  
 157 where  $\alpha_{rust}$  is the molecular weight of steel divided by the molecular weight of corrosion  
 158 products. It varies from 0.523 to 0.622 according to different types of corrosion products [2].  
 159  $\rho_{rust}$  is the density of corrosion products and  $\rho_{st}$  is the density of steel.

160

161 By neglecting the second order of small quantities, i.e.,  $d_0 d_m$  and  $d_0^2$ ,  $d_m$  can be derived as  
 162 follows:

163

$$164 \quad d_m = \frac{4W_{rust}}{\pi D} \left( \frac{1}{\rho_{rust}} - \frac{\alpha_{rust}}{\rho_{st}} \right) - 2d_0 \quad (2)$$

165 To determine the displacement boundary condition caused by the rust expansion of the rebar,  
 166 the function of the semi-ellipse of the corrosion front in rectangular coordinate system can be  
 167 expressed as follows:

$$168 \quad \frac{y^2}{\left( \frac{D}{2} + d_0 + d_m \right)^2} + \frac{x^2}{\left( \frac{D}{2} + d_0 \right)^2} = 1 \quad (3)$$

169 Equation (3) can be transformed in a polar coordinate system. By considering the original  
 170 location of inner boundary of the concrete, i.e.,  $D/2 + d_0$ , the displacement boundary  
 171 condition can be derived as follows,

172

$$173 \quad r = \frac{(D + 2d_0 + 2d_m)(D + 2d_0)}{\sqrt{(2D + 4d_0)^2 + 16d_m(D + 2d_0 + d_m)\cos^2 \theta}} - \frac{D}{2} - d_0 \quad (4)$$

174 where  $0 \leq \theta \leq \pi$ .

175

176 By substituting Equations (2) in to Equations (4), the displacement boundary condition of  
 177 concrete  $\delta(\theta, t)$  can be derived as follows:

$$178 \quad \delta(\theta, t) = \frac{\left[ D + 2d_0 + \frac{8W_{rust}(t)}{\pi D} \left( \frac{1}{\rho_{rust}} - \frac{\alpha_{rust}}{\rho_{st}} \right) - 4d_0 \right] (D + 2d_0)}{\sqrt{(2D + 4d_0)^2 + 32 \left[ \frac{2W_{rust}(t)}{\pi D} \left( \frac{1}{\rho_{rust}} - \frac{\alpha_{rust}}{\rho_{st}} \right) - d_0 \right] \left[ D + 2d_0 + \frac{4W_{rust}(t)}{\pi D} \left( \frac{1}{\rho_{rust}} - \frac{\alpha_{rust}}{\rho_{st}} \right) - 2d_0 \right] \cos^2 \theta}} - \frac{D}{2} - d_0 \quad (5)$$

179 where  $0 \leq \theta \leq \pi$ .

180

181 In Equations (5),  $W_{rust}(t)$  is related to the corrosion rate of the steel bar and can be expressed

182 as follows [2]:

$$183 \quad W_{rust}(t) = \sqrt{2 \int_0^t 0.105(1/\alpha_{rust}) \pi D i_{corr}(t) dt} \quad (6)$$

184  $W_{rust}(t)$  is the total amount of rust products at time  $t$ .  $i_{corr}$  is the corrosion current density and

185  $t$  is time after corrosion initiation. The units of these variables are presented in Tables.

186

187 As described in Equations 5 and 6, the corrosion rate  $i_{corr}$  can be the most important single

188 factor controlling the amount of corrosion products which determines the displacement

189 boundary condition of concrete. Based on previous studies on experiments and simulations in

190 terms of corrosion initiation, corrosion propagation and cover cracking [13, 24, 26, 32-34],

191 etc., the corrosion process of steel bar in concrete for the whole life-cycle could be divided

192 into six stages: (1) no corrosion—chloride ions penetrate the concrete cover and reach to the

193 threshold value; (2) corrosion initiation—gradual depassivation process of the steel bar; (3)

194 corrosion products free expansion—the oxygen and moisture supply in the “porous zone”

195 gradually reduce while the rust occupies the “porous zone”; (4) steady corrosion—the

196 equilibrium between consuming and transporting oxygen and moisture is maintained; (5)

197 accelerated corrosion—caused by significant cracking which leads to faster transport of

198 oxygen and moisture; and (6) final steady corrosion—the reinforcing bar exposes to chloride

199 and atmosphere directly. The development of corrosion rate in the whole life-cycle of RC  
 200 structures can be schematically shown in Figure 2.

201

202 This paper mainly focuses on the time from corrosion initiation to surface cracking (crack  
 203 width smaller than 0.3-0.6mm). The time needed for chlorides to penetrate the concrete to the  
 204 depth of the reinforcement (i.e., Stage 1) is excluded. Since stage 2 is usually very short and  
 205 stages (5) and (6) are normally beyond the serviceability of RC structures, the corrosion rate  
 206 for the stages (3) and (4) in the whole life-cycle of RC structures can be expressed as follows  
 207 [27]:

208

$$209 \quad i_{corr} = \frac{1}{2} \delta \left\{ 3 \times 10^{-2} \exp\left[9500\left(\frac{1}{298} - \frac{1}{T}\right)\right] \right\}^{0.5} \left\{ \left[ 1 \times 10^{-3} \exp\left[2612\left(\frac{1}{T} - \frac{1}{298}\right)\right] \right] \right\}^{0.5} \exp\left[\frac{522+1.44T}{\beta(t, R_{con})}\right] \quad (7)$$

$$210 \quad \beta(t, R_{con}) = \begin{cases} [143.78 - 54 \times (w/c) + 0.018R_{1,con}] + [0.78 - 0.92 \times (w/c) - 1.2 \times 10^{-4} R_{con}] \times t, (t_1 \leq t < t_2) \\ [143.78 - 54 \times (w/c) + 0.018R_{1,con}] + [0.78 - 0.92 \times (w/c) - 1.2 \times 10^{-4} R_{con}] \times t_2, (t_2 \leq t < t_3) \end{cases}$$

211

212 where  $\delta$  is the ratio of activation area to the total surface area, which is 0.5 in the non-  
 213 uniform corrosion model;  $T$  is the absolute temperature of concrete, which can be considered  
 214 as the same as the ambient temperature due of the lack of true temperature data of the internal  
 215 concrete;  $\beta(t, R_{con})$  is the natural logarithm Tafel slopes of the polarization curve.  $w/c$  is the  
 216 water cement ratio;  $t_1$ ,  $t_2$  and  $t_3$  are times illustrated in Figure 2. At  $t_2$ , the amount of  
 217 corrosion products  $W_{rust}(t_2)$  fully fills in the “porous zone”, with the thickness  $d_0$ ; therefore,  
 218 Equation (1) can be re-written as follows,

$$219 \quad \frac{2W_{rust}(t_2)}{\pi D} \left( \frac{1}{\rho_{rust}} - \frac{\alpha_{rust}}{\rho_{st}} \right) = d_0 \quad (8)$$

220

221  $t_2$  can be determine by combining the Equations (6) and (8). In Equation (7),  $R_{con}$  is the  
222 resistivity of concrete, which is related to water cement ratio  $w/c$ , chloride content  $Cl^-$ ,  
223 temperature  $T$  and pore water saturation  $P$ , with the expression presented as follows [27]:

224

$$225 \quad R_{con} = [750,605 \times (w/c) - 106,228] \times \exp[-44.17 \times Cl^- - 7.7213 \times P + 2889(\frac{1}{T} - \frac{1}{303})] \quad (9)$$

226  $R_{1,con}$  is the resistivity of concrete at time  $t_1$ .

227

228 It has been found that surface chloride concentration does not change significantly with time  
229 for most RC structures in coastal zone [13]. Moreover, numerical simulations on chloride  
230 diffusion indicated that after corrosion initiation, the chloride content in concrete will not  
231 increase significantly given constant value of surface chloride concentration under natural  
232 environment [35]. The pore water saturation  $P$  is related to internal relative humidity and  
233 temperature. Although the relative humidity and temperature in nature climate changes  
234 considerably, pore water saturation  $P$  does not change much because of the response  
235 hysteresis of concrete to external climate [28]. Therefore, temperature could be the most  
236 significant factor that affects the corrosion rate after corrosion initiation in concrete under an  
237 atmospheric environment. Similar statements have been found in previous literatures, e.g. [28,  
238 35].

239

#### 240 **4 COVER CRACKING MODEL**

241 Concrete is modelled as a quasi-brittle material, with its constitutive tensile stress-  
242 displacement relation ( $\sigma - \delta$ ) illustrated in Figure 3. To model the arbitrary cracking in  
243 concrete, cohesive elements are embedded in the mesh which is sufficiently fine. The  
244 insertion process of cohesive elements is shown in Figure 4. First, all individual nodes are  
245 replaced by certain number of new nodes at the same location. The number of newly created

246 nodes depends on the number of the elements connecting to the original node. Second, the  
247 newly created nodes at the interface between two triangle elements are identified and linked  
248 to form a cohesive element. The cohesive elements are shown in red in Figure 4. This  
249 insertion process was conducted by a script written in Python. Moreover, it should be  
250 mentioned that the cohesive elements generated are of zero thickness in geometry. The two  
251 nodes of a cohesive element, in the thickness direction, share the same coordinates before  
252 loading. The constitutive/calculation thickness of the cohesive elements, however, is 1.0 for  
253 the convenience of transformation between strain and displacement.

254

255 Figure 5 shows a RC beam with four tensile reinforcing bars and two compressive reinforcing  
256 bars. In light of reducing the computing time, only half of the structure is modelled due to the  
257 symmetry of the structure and the loading, as illustrated in Figure 5. The beam is modelled in  
258 2D since it is a plane strain problem. Two elements are employed in this study, i.e., 4-node  
259 cohesive elements at all interfaces between the triangle solid elements, and 3-node plane  
260 strain element for the bulk intact concrete. The size of solid elements in the region close to the  
261 corrosion products varies from 0.6 mm to 1.5 mm while the size in other region varies from  
262 1.5 mm to 15 mm. Very fine mesh is generated before inserting sufficient number of cohesive  
263 elements. The meshed structure is shown in Figure 6. There are 12,040 solid triangle elements  
264 and 17,865 cohesive elements inserted, for half of the structure with clear spacing between  
265 tensile rebars of 30 mm. The expansive behaviour of non-uniform corrosion is modelled by  
266 applying radial expansive displacement to the concrete structure.

267

## 268 **5 RESULTS AND VALIDATION**

### 269 **5.1 Worked example**

270 To demonstrate the application of the derived method, the time-dependent corrosion rate is  
271 first calculated. The average monthly temperature in England from 1996-2016 is used which

272 is listed in Table 1 [36]. According to the data in Table 1, the temperature can be analytically  
273 formulated and expressed as a function of time:

$$274 \quad T = -5.98 \times \cos((t - 0.5) \times (2\pi)) + 10.39 \quad (10)$$

275 where  $T$  is in Centigrade and should be transformed to absolute temperature to calculate the  
276 corrosion rate in Equation 7.  $t$  is the time in year.

277

278 With the values for input parameters shown in Table 2 the corrosion rate for the whole life-  
279 cycle from corrosion initiation to surface crack width up to 0.3-0.6 mm can be obtained and  
280 shown in Figure 7. It should be noted that the initial increase of corrosion rate, i.e., stage 2 in  
281 Figure 2, is neglected in the whole life-cycle analysis in this study since the period is  
282 negligibly small. It can be seen that, in the free expansion stage, the corrosion rate  $i_{corr}$   
283 decreases from 1.69 to 1.07  $\mu\text{A}/\text{cm}^2$ , and the “porous zone” is fully filled with the corrosion  
284 products. This process takes about 0.07 year. As discussed, the reason for the drop of  
285 corrosion rate is because the consumption of oxygen in the “porous zone”. In the steady  
286 corrosion stage, the fluctuation of corrosion rate is caused by the seasonal variation of  
287 temperature. The lowest corrosion rate is 0.63  $\mu\text{A}/\text{cm}^2$  and the highest is 1.1  $\mu\text{A}/\text{cm}^2$ .

288

289 After calculating the time-dependent corrosion rate, the maximum non-uniform corrosion  
290 induced expansive displacement  $d_m(t)$ , as illustrated in Figure 1, can be shown as a function  
291 of time after corrosion initiation in Figure 8. For better evaluating the time-dependent  
292 corrosion rate, developments of corrosion expansion  $d_m(t)$  under three constant corrosion  
293 rates ( $i_{corr} = 0.5, 1.0$  and  $2.0 \mu\text{A}/\text{cm}^2$ ) are plotted. First, it has been found that the growth  
294 curves of  $d_m(t)$  over time for constant corrosion rates are rather smooth while that for the  
295 time-dependent corrosion is slightly fluctuating. This is because the model proposed in this

296 paper for corrosion rate is a function of temperature which changes during a year. The  $d_m(t)$   
297 curve for the time-dependent corrosion rate initially falls in between the curves for  $i_{corr} = 1.0$   
298  $\mu\text{A}/\text{cm}^2$  and  $2.0 \mu\text{A}/\text{cm}^2$ , respectively; after about 0.4 year, however, the time-dependent  
299 curve progresses below the curve for  $i_{corr} = 1.0 \mu\text{A}/\text{cm}^2$ . Therefore, it would be hard to find  
300 any constant corrosion rate to represent the time-dependent corrosion rate in terms of the  
301 development of corrosion induced expansion over time. This also justifies the use of time-  
302 dependent corrosion rate rather than constant corrosion rate. For the time-dependent corrosion  
303 rate, corrosion starts to cause stress/displacement onto concrete at 0.07 year.

304

## 305 **5.2 Cover failure modes**

306 A number of combinations of reinforcement clear spacing ( $S$ ) and fracture energy of concrete  
307 ( $G_f$ ) are modelled in this study to investigate the cover failure patterns caused by corrosion of  
308 multiple reinforcements. Three values of the reinforcement spacing ( $S$ ), i.e., 30 mm, 45 mm  
309 and 60 mm, and three fracture energy of concrete ( $G_f$ ) 60 N/m, 90 N/m and 120 N/m, are used.  
310 The geometric and mechanical parameters of the RC structures are shown in Table 3. There  
311 are two typical failure patterns of the cover structure which have been found. The cracking  
312 patterns and time to cracking for different combinations of reinforcement spacing ( $S$ ) and  
313 fracture energy of concrete ( $G_f$ ) are presented in Table 4. As shown in Figure 9, the first  
314 pattern has a through crack between reinforcing bars and a side crack whilst no top crack is  
315 visible. Such a pattern is considered as a delamination failure of the cover. For the other  
316 pattern, however, there is a top crack above the side reinforcing bar, other than the through  
317 crack and the side crack. This pattern tends to cause spalling of the corner concrete cover and  
318 hence it is regarded as a combined delamination and corner spalling failure of the cover. In  
319 general, relative small values of reinforcement spacing and fracture energy of concrete tend to  
320 cause typical delamination failure of concrete cover while high values of these two parameters

321 tend to lead to spalling failure of concrete corner. Discussions on the effects of reinforcement  
322 spacing and fracture energy of concrete on the cover failure will be presented in Section 6.

323

### 324 **5.3 Verification**

325 The derived model is verified by comparing the time to surface cracking with experiments  
326 from literature [37]. According to the literature searched, almost all the test data regarding to  
327 the time to cracking for multiple reinforcement corrosion are based on uniform corrosion  
328 development by electric current method for accelerated corrosion [32, 37, 38]. As such, a  
329 special numerical case on uniform corrosion is conducted and the results are compared with  
330 those from experiments [37]. The same inputs from the tests are used in the numerical  
331 simulation, which are presented in Table 5. The correlation between the time and uniform  
332 corrosion expansion is achieved by the corrosion model presented in Li and Yang [1]. The  
333 comparisons of crack width for the side reinforcing bar between the developed model and the  
334 experimental results are illustrated in Figure 10. It can be found that the progress of crack  
335 width simulated is in reasonably good agreement with the experimental results. The time to  
336 surface cracking in the experiment is 72 hours, which is very close to the time when crack  
337 width reaches 0.02mm from the simulation. It should be mentioned that, in the experiment,  
338 the measured time to crack initiation and propagation is calibrated as it was for corrosion rate  
339  $100 \mu\text{A}/\text{cm}^2$  and the surface crack initiation is obtained by a crack detection microscope with  
340 an accuracy of 0.02mm.

341

### 342 **5.4 Justification of top crack**

343 It is very interesting to find that, in the combined delamination and corner spalling failure  
344 mode, the top crack always starts from the outer surface and propagates inwards to the  
345 reinforcing bar. This is different from the common perspective on corrosion-induced cracking  
346 which is usually considered to be initiated from inside to outside of the concrete cover.

347 Similar results have been found in experimental tests from S. Caré *et al.* [39] and damage  
348 simulations from Du *et al.* [29] which indicated that a vertical crack was generated at surface  
349 of concrete and propagated towards the rebar. To thoroughly investigate this problem, the  
350 stress distributions (maximum principal stress) of the corner rebar region under uniform  
351 corrosion and non-uniform corrosion respectively are plotted in Figure 11. It can be found  
352 that, for uniform corrosion, the maximum principal stress concentrates around the  
353 reinforcement in a relative uniform manner. By sign convention, the maximum principal  
354 stress is tensile stress. The maximum principal stresses for all elements in this region are  
355 tensile stresses while largest stress occurs at the inner boundary, according to Figure 11 (a).  
356 This is why the uniform corrosion-induced crack is always initiated at the inner boundary.  
357 For the non-uniform corrosion developed from this study, the stress concentrates around two  
358 sides of the inner boundary — roughly at 10 degrees above the horizontal direction, as  
359 illustrated in Figure 11 (b). This is where the side crack is initiated; after that, the side crack  
360 propagates towards the side surface. A closer look is shown in Figure 12 (a) in which a tensile  
361 stress concentration is clearly demonstrated. However, for the potential top crack, the inner  
362 boundary region is in bi-axial compression, as illustrated in Figure 12 (b). It is therefore  
363 impossible to have a crack initiated here. However, at the top surface, the region is in tension  
364 in the x-direction where the top crack should start. The different stress distributions for  
365 uniform and non-uniform corrosion models determine the cracking patterns of the concrete  
366 cover and explain why the non-uniform corrosion induced top crack is initiated from the top  
367 surface, rather than from the inner boundary of concrete cover.

368

## 369 **6 ANALYSIS AND DISCUSSION**

### 370 **6.1 Corrosion parameters**

371 Corrosion rate has been considered as one of the key factors affecting the durability of  
372 reinforced concrete structures. The effect of constant corrosion rates on time to surface  
373 cracking for the model (spacing of reinforcement 45 mm and fracture energy 90 N/m) is  
374 investigated and shown in Figure 13. It can be found that the increase of corrosion rate  
375 reduces the time to surface cracking. For relatively low corrosion rate, e.g.,  $i_{corr}$  is smaller  
376 than  $1.0 \mu\text{A}/\text{cm}^2$ , the time to surface cracking decreases sharply from 7.5 years to 0.75 year.  
377 However, for moderate or high rate of corrosion, e.g.,  $i_{corr}$  is larger than  $1.0 \mu\text{A}/\text{cm}^2$ , the time  
378 to surface cracking does not change dramatically.

379

380 One of the advantages of the corrosion model developed in this paper is that the corrosion rate  
381 is directly related to ambient temperature and chloride content in concrete cover. To  
382 investigate the effect of temperature on the time to surface cracking, values of temperature in  
383 range of 5-35°C are used to calculate the constant corrosion rates. The time to surface  
384 cracking for the model (spacing of reinforcement 45mm, fracture energy 90N/m and chloride-  
385 ion content 3.034%) as a function of temperature is shown as Figure 14. It can be seen that,  
386 the concrete cover surface cracking is advanced from about 1.5 years to 0.2 year, as the  
387 temperature changes from 5°C to 35°C. This proves that the time to surface cracking is very  
388 sensitive to temperature. However, it has also been found the surface cracking is more  
389 sensitive to changes of temperature lower than 25°C, than that of temperature higher than  
390 25°C.

391

392 The effects of chloride content in concrete on the cracking of concrete cover have also been  
393 investigated which is shown in Figure 15. As expected, the time to surface cracking is  
394 reduced as the content of chloride ions increases. When chloride ions content is increased  
395 from 1% to 4%, the time to surface cracking is advanced from 2.17 years to 0.84 year. After

396 4% chloride concentration up to 7% investigated, the decrease in time to surface cracking is  
397 only 0.23 year down to 0.61 year. Therefore, it can be postulated that the cracking of concrete  
398 cover is very sensitive to the change of low chloride concentrations up to 4%.

399

## 400 **6.2 Crack width**

401 To investigate the effect of corrosion rate on evolution of surface crack width, the model for  
402 spacing of reinforcement 30 mm and fracture energy 60 N/m is taken as an example based on  
403 time-dependent corrosion rate and three constant low/moderate corrosion rates, i.e.,  $i_{corr} = 0.5$   
404  $\mu\text{A}/\text{cm}^2$ ,  $i_{corr} = 1.0 \mu\text{A}/\text{cm}^2$  and  $i_{corr} = 2.0 \mu\text{A}/\text{cm}^2$ . The crack width is obtained by measuring  
405 the distance between the nodes of the cohesive element at surface of concrete cover. It should  
406 be noted that, before the surface cracking, i.e., cohesive element being deleted, the cohesive  
407 element already has a deformation according to the constitutive definition of the cohesive  
408 elements. This displacement should be disregarded from the crack width calculation. As  
409 illustrated in Figure 16, the increase of corrosion rate can cause significant reduce in time to  
410 surface cracking. The initial sudden increases in the surface crack width for different  
411 corrosion rate are almost the same since the geometry and mechanical parameters in these  
412 models are the same. Further, higher corrosion rate can result in considerably larger surface  
413 crack width than lower corrosion rate, for long-term crack width growth. It should be  
414 mentioned that since the corrosion mechanism will change significantly after the crack width  
415 larger than 0.3 mm [26] which is not considered in the developed model, only 10-year service  
416 life is investigated in which the crack widths for most cases are smaller than 0.25 mm.

417

418 The effects of the fracture energy on development of side and top surface cracks are shown as  
419 Figures 17 and 18. In Figure 17, it can be seen that larger fracture energy of concrete will  
420 delay the time to side surface cracking and cause larger initial sudden increase in the crack

421 width. However, the differences in time to surface cracking and initial crack width  
422 development are both very small. Moreover, the long-term developments of the crack width  
423 for these two cases investigated are almost identical. Figure 18 illustrates the effect of the  
424 fracture energy of concrete on the development of top surface crack width. Similarly, larger  
425 fracture energy of concrete will result in larger initial increase of crack width and longer  
426 cracking time. The fracture energy of concrete has little effect on the long-term development  
427 of top surface crack width. It is interesting to find that, when the through crack completely  
428 forms, there is a sudden drop in top surface crack width. Such an effect of formation of  
429 through crack on the surface crack growth has not been found in previous literatures.

430

431 The effect of spacing between reinforcing bars  $S$  on the top surface crack width is shown in  
432 Figure 19. Fracture energy 120 N/m is used in this analysis. It can be found that the initial  
433 crack width growth is significantly affected by the spacing between reinforcements while the  
434 long-term developments of crack width are almost the same. Further, there is a sudden drop of  
435 crack width for  $S = 60$  mm which is caused by the complete formation of the through crack.  
436 As explained, when the through crack is formed, there will be a sudden energy release which  
437 leads to unloading of the other cracks. There is no drop for  $S = 30$  and 45mm because the  
438 through crack forms ahead of the initiation of the top crack.

439

### 440 **6.3 Cracking time**

441 Although the through crack is an internal crack which can be less important in terms of the  
442 durability, it has significant effects on the development of surface cracks, i.e., the side and top  
443 cracks. Figure 20 (a) shows the effects of fracture energy of concrete and spacing between  
444 reinforcing bars on time to complete formation of through crack. It can be seen that the larger  
445 the fracture energy of concrete or the spacing between reinforcements is, the longer the time  
446 to formation of through crack is. Moreover, the effects of fracture energy of concrete and

447 spacing between reinforcing bars on time to initiation of top crack are shown in Figure 20 (b).  
448 Only results of  $S = 45$  and  $60$  mm are plotted because there is no top crack for most cases of  $S$   
449  $= 30$  mm, i.e., delamination mechanism in Figure 9. Again, it has been found that the increase  
450 of fracture energy of concrete can delay the time to initiation of top crack. In addition, the  
451 effect of spacing is very sensitive, for larger fracture energy of concrete. For fracture energy  
452  $60$  and  $90$  N/m, there are almost no differences between cases of  $S = 45$  and  $60$  mm, whilst the  
453 time to initiation of top crack is nearly doubled for fracture energy  $120$  N/m. This finding  
454 should be very helpful for structural engineers in regards to their consideration of durability  
455 design of RC structures. Nevertheless, more simulations will be ideal in the future for some  
456 extra clarification; for example, more values of spacing between reinforcements.

457

#### 458 **6.4 Crack path**

459 To investigate the change of normal stress (crack driving force) of the cohesive elements  
460 along the cracks over time, Figures 21 and 22 are plotted for the side crack and the top crack  
461 respectively. The spacing between reinforcements is taken  $30$  mm and the fracture energy is  
462  $120$  N/m. The normal stress distributions of cohesive elements along the side crack are shown  
463 for  $0.12$  year,  $1.13$  years and  $10$  years in Figure 21. There are  $19$  elements in the path of side  
464 crack and the elements are ordered from the surface of concrete to the inner boundary. At  $0.12$   
465 year, the first element (no.  $19$ ) from the inner boundary approaches the tensile strength. As the  
466 load increases, the side crack is initiated and the peak stress moves along the crack path  
467 towards the surface. At  $1.13$  year, the peak stress moves to the location of element no.  $4$  while  
468 the normal stresses for all previously cracked cohesive elements soften/degrade to certain  
469 values, according to its constitutive stress-displacement ration defined in Figure 3. For this  
470 example, because of the existence of top crack, the surface region of the side crack is always  
471 in compression as shown in Figure 12. Even at  $10$  years, the side crack tip can only reach the  
472 cohesive element no.  $2$  whilst the first cohesive element from the surface is in significant

473 compression, more than 10 MPa. This reflects complex nature of the problem for non-uniform  
474 corrosion of multiple reinforcing bars.

475

476 Figure 22 shows the normal stress distributions of cohesive elements along the top crack  
477 under the case of reinforcement spacing 30 mm and fracture energy 120 N/m. It can be seen  
478 that the peak tensile stress moves from the cohesive element no. 21 (at the top surface) to the  
479 cohesive element no. 2 (close to the inner boundary), as time increases. At 0.12 year, the  
480 concrete near reinforcing bar is in compression while the concrete near the surface of concrete  
481 is in tension. As explained earlier, this is why the top crack is initiated at the top, rather than  
482 at the inner boundary. From 0.12 to 1.43 years, the top crack propagates fast, i.e., the peak  
483 tensile stress moves from cohesive element no. 21 to no. 6; the location of peak tensile stress  
484 is usually referred to as the start of fracture process zone or the fictitious crack front,  
485 according to definition of cohesive crack model [40].

486

## 487 **7 CONCLUSIONS**

488 A combined analytical and numerical method has been presented to predict the time to cover  
489 cracking and the crack width under non-uniform corrosion of multiple reinforcing bars of RC  
490 structures. The non-uniform corrosion model was derived based on experimental results and  
491 formulated as a function of time. Under the non-uniform corrosion-induced expansion, a  
492 fracture model was established to simulate arbitrary cracking of the cover of RC structures  
493 with multiple reinforcing bars. The times to cracking and failure modes of concrete cover  
494 affected by fracture energy of concrete and spacing between reinforcing bars were obtained  
495 and discussed. To validate the developed model, comparisons with experimental results from  
496 literature were carried out. It has been found that the time to surface cracking is significantly  
497 affected by ambient temperature, chloride content and corrosion rate. It has also been found

498 that two cover failure modes exist, depending on the spacing of reinforcing bars and fracture  
499 energy of concrete. It can be concluded that the developed combined analytical and numerical  
500 model can be used to accurately simulate the time to cover cracking and the crack width  
501 evolution of RC structures caused by non-uniform corrosion of multiple reinforcing bars.

502

### 503 **ACKNOWLEDGEMENT**

504 Financial support from National Key R&D Plan of China (Grant No: 2016YFC0600801) is  
505 gratefully acknowledged. The first author is also funded by China Scholarship Council for his  
506 PhD research at University of Strathclyde, UK.

507

### 508 **REFERENCES**

- 509 [1] C. Q. Li, and S. T. Yang, "Prediction of concrete crack width under combined  
510 reinforcement corrosion and applied load," *Journal of Engineering Mechanics-ASCE*,  
511 vol. 137, no. 11, pp. 722-731, 2011.
- 512 [2] Y. Liu, and R. E. Weyers, "Modelling the time-to-corrosion cracking in chloride  
513 contaminated reinforced concrete structures," *ACI Materials Journal*, vol. 95, no. 6,  
514 pp. 675-681, 1998.
- 515 [3] K. Bhargava, A. K. Ghosh, Y. Mori *et al.*, "Model for cover cracking due to rebar  
516 corrosion in RC structures," *Engineering Structures*, vol. 28, no. 8, pp. 1093-1109,  
517 2006.
- 518 [4] S. J. Pantazopoulou, and K. D. Papoulia, "Modeling cover cracking due to  
519 reinforcement corrosion in RC structures," *Journal of Engineering Mechanics-ASCE*,  
520 vol. 127, no. 4, pp. 342-351, 2001.
- 521 [5] M. Elices, C. Rocco, and C. Roselló, "Cohesive crack modelling of a simple concrete:  
522 Experimental and numerical results," *Engineering Fracture Mechanics*, vol. 76, no.  
523 10, pp. 1398-1410, 2009.
- 524 [6] C. Andrade, C. Alonso, and F. J. Molina, "Cover cracking as a function of bar  
525 corrosion: Part I-Experimental test," *Materials and Structures*, vol. 26, no. 8, pp. 453-  
526 464, 1993.
- 527 [7] C. Q. Li, "Time Dependent Reliability Analysis of the Serviceability of Corrosion  
528 Affected Concrete Structures," *International Journal of Materials and Structural  
529 Reliability*, vol. 3, no. 2, pp. 105-116, 2005.
- 530 [8] L. Chernin, and D. V. Val, "Prediction of corrosion-induced cover cracking in  
531 reinforced concrete structures," *Construction and Building Materials*, vol. 25, no. 4,  
532 pp. 1854-1869, 2011.
- 533 [9] C. Q. Li, R. E. Melchers, and J. J. Zheng, "Analytical model for corrosion-induced  
534 crack width in reinforced concrete structures," *ACI Structural Journal*, vol. 103, no. 4,  
535 pp. 479-487, 2006.

- 536 [10] L. Jin, R. Zhang, X. Du *et al.*, "Investigation on the cracking behavior of concrete  
537 cover induced by corner located rebar corrosion," *Engineering Failure Analysis*, vol.  
538 52, pp. 129-143, 2015.
- 539 [11] E. Chen, and C. K. Y. Leung, "Finite element modeling of concrete cover cracking  
540 due to non-uniform steel corrosion," *Engineering Fracture Mechanics*, vol. 134, pp.  
541 61-78, 2015.
- 542 [12] C. Cao, and M. M. S. Cheung, "Non-uniform rust expansion for chloride-induced  
543 pitting corrosion in RC structures," *Construction and Building Materials*, vol. 51, pp.  
544 75-81, 2014.
- 545 [13] K. A. T. Vu, and M. G. Stewart, "Structural reliability of concrete bridges including  
546 improved chloride-induced corrosion models," *Structural Safety*, vol. 22, no. 4, pp.  
547 313-333, 2000.
- 548 [14] M. G. Stewart, "Spatial variability of pitting corrosion and its influence on structural  
549 fragility and reliability of RC beams in flexure," *Structural Safety*, vol. 26, no. 4, pp.  
550 453-470, 2004.
- 551 [15] J. A. González, C. Andrade, C. Alonso *et al.*, "Comparison of rates of general  
552 corrosion and maximum pitting penetration on concrete embedded steel  
553 reinforcement," *Cement and Concrete Research*, vol. 25, no. 2, pp. 257-264, 1995.
- 554 [16] Y. Yuan, and Y. Ji, "Modeling corroded section configuration of steel bar in concrete  
555 structure," *Construction and Building Materials*, vol. 23, no. 6, pp. 2461-2466, 2009.
- 556 [17] B. S. Jang, and B. H. Oh, "Effects of non-uniform corrosion on the cracking and  
557 service life of reinforced concrete structures," *Cement and Concrete Research*, vol.  
558 40, no. 9, pp. 1441-1450, 2010.
- 559 [18] B. Šavija, M. Luković, J. Pacheco *et al.*, "Cracking of the concrete cover due to  
560 reinforcement corrosion: A two-dimensional lattice model study," *Construction and  
561 Building Materials*, vol. 44, pp. 626-638, 2013.
- 562 [19] A. Chen, Z. Pan, and R. Ma, "Mesoscopic simulation of steel rebar corrosion process  
563 in concrete and its damage to concrete cover," *Structure and Infrastructure  
564 Engineering*, vol. 13, no. 4, pp. 478-493, 2016.
- 565 [20] Y. Zhao, A. R. Karimi, H. S. Wong *et al.*, "Comparison of uniform and non-uniform  
566 corrosion induced damage in reinforced concrete based on a Gaussian description of  
567 the corrosion layer," *Corrosion Science*, vol. 53, no. 9, pp. 2803-2814, 2011.
- 568 [21] Z. P. Bazant, "Physical model for steel corrosion in concrete sea structures - theory,"  
569 *Journal of the Structural Division-ASCE*, vol. 105, no. 6, pp. 1137-1153, 1979.
- 570 [22] C. Andrade, F. J. Molina, and C. Alonso, "Cover cracking as a function of rebar  
571 corrosion: Part 1-experiment test," *Materials and Structures*, vol. 26, pp. 453-454,  
572 1993.
- 573 [23] C. Lu, W. Jin, and R. Liu, "Reinforcement corrosion-induced cover cracking and its  
574 time prediction for reinforced concrete structures," *Corrosion Science*, vol. 53, no. 4,  
575 pp. 1337-1347, 2011.
- 576 [24] C. Cao, M. M. S. Cheung, and B. Y. B. Chan, "Modelling of interaction between  
577 corrosion-induced concrete cover crack and steel corrosion rate," *Corrosion Science*,  
578 vol. 69, pp. 97-109, 2013.
- 579 [25] Y. Yuan, Y. Ji, and J. Jiang, "Effect of corrosion layer of steel bar in concrete on time-  
580 variant corrosion rate," *Materials and Structures*, vol. 42, no. 10, pp. 1443-1450,  
581 2009.
- 582 [26] Y. Yuan, J. Jiang, and T. Peng, "Corrosion process of steel bar in concrete in full  
583 lifetime," *ACI Materials Journal*, vol. 107, no. 6, pp. 562-568, 2010.
- 584 [27] J. Jiang, and Y. Yuan, "Prediction model for the time-varying corrosion rate of rebar  
585 based on micro-environment in concrete," *Construction and Building Materials*, vol.  
586 35, pp. 625-632, 2012.

- 587 [28] J. Jiang, and Y. Yuan, "Development and prediction strategy of steel corrosion rate in  
588 concrete under natural climate," *Construction and Building Materials*, vol. 44, pp.  
589 287-292, 2013.
- 590 [29] X. Du, L. Jin, and R. Zhang, "Modeling the cracking of cover concrete due to non-  
591 uniform corrosion of reinforcement," *Corrosion Science*, vol. 89, pp. 189-202, 2014.
- 592 [30] A. Jamali, U. Angst, B. Adey *et al.*, "Modeling of corrosion-induced concrete cover  
593 cracking: A critical analysis," *Construction and Building Materials*, vol. 42, pp. 225-  
594 237, 2013.
- 595 [31] J. Zhang, X. Ling, and Z. Guan, "Finite element modeling of concrete cover crack  
596 propagation due to non-uniform corrosion of reinforcement," *Construction and  
597 Building Materials*, vol. 132, pp. 487-499, 2017.
- 598 [32] K. Vu, M. G. Stewart, and J. Mullard, "Corrosion-induced cracking: Experimental  
599 data and predictive models," *ACI Structural Journal*, vol. 102, no. 5, pp. 719-726,  
600 2005.
- 601 [33] W. Jung, "Predicting the remaining service life of land concrete by steel corrosion,"  
602 *Cement and Concrete Research*, vol. 33, no. 5, pp. 663-677, 2003.
- 603 [34] R. Zhang, A. Castel, and R. François, "The corrosion pattern of reinforcement and its  
604 influence on serviceability of reinforced concrete members in chloride environment,"  
605 *Cement and Concrete Research*, vol. 39, no. 11, pp. 1077-1086, 2009.
- 606 [35] D. Chen, and S. Mahadevan, "Chloride-induced reinforcement corrosion and concrete  
607 cracking simulation," *Cement and Concrete Composites*, vol. 30, no. 3, pp. 227-238,  
608 2008.
- 609 [36] Metoffice.uk, "UK temperature, rainfall and sunshine anomaly graphs,"  
610 <http://www.metoffice.gov.uk/climate/uk/summaries/datasets>, 2017.
- 611 [37] A. S. Al-Harthy, M. G. Stewart, and J. Mullard, "Concrete cover cracking caused by  
612 steel reinforcement corrosion," *Magazine of Concrete Research*, vol. 63, no. 9, pp.  
613 655-667, 2011.
- 614 [38] J. A. Mullard, and M. G. Stewart, "Corrosion-induced cover cracking: new test data  
615 and predictive models," *ACI Structural Journal*, vol. 108, no. 1, pp. 71-79, 2011.
- 616 [39] S. Caré, Q. T. Nguyen, K. Beddiar *et al.*, "Times to cracking in reinforced mortar  
617 beams subjected to accelerated corrosion tests," *Materials and Structures*, vol. 43, no.  
618 1-2, pp. 107-124, 2009.
- 619 [40] A. Hillerborg, M. Modeer, and P. E. Petersson, "Analysis of crack formation and  
620 crack growth in concrete by means of fracture mechanics and finite elements," *Cement  
621 and Concrete Research*, vol. 6, no. 6, pp. 773-781, 1976.
- 622 [41] C. Q. Li, "Life-cycle modelling of corrosion-affected concrete structures:  
623 Propagation," *Journal of Structural Engineering-ASCE* vol. 129, no. 6, pp. 753-761,  
624 2003.
- 625 [42] S. P. Timoshenko, and J. N. Goodier, *Theory of Elasticity*, 3rd ed., Singapore, 1970.
- 626 [43] X. Shilang, *Determination of parameters in the bilinear, Reinhardt's nonlinear and  
627 exponentially non-linear softening curves and their physical meanings*, University of  
628 Stuttgart, Stuttgart, 1999.
- 629 [44] S. Xu, and X. Zhang, "Determination of fracture parameters for crack propagation in  
630 concrete using an energy approach," *Engineering Fracture Mechanics*, vol. 75, no. 15,  
631 pp. 4292-4308, 2008.
- 632

633 **LIST OF TABLES**

- 634 1. The average monthly temperature in England from 1996-2016 (°C)
- 635 2. Values of basic variables used in the time-dependent non-uniform corrosion model
- 636 3. Values for geometric and mechanical parameters in the examples
- 637 4. Crack patterns and time to cracking for different combinations of fracture energy and  
638 reinforcement clear spacing
- 639 5. Values for basic variables used for validation

640 Table 1 The average monthly temperature in England from 1996-2016 (°C) [36]

Jan.	Feb.	Mar.	Apr.	May.	Jun.	Jul.	Aug.	Sept.	Oct.	Nov.	Dec.
4.41	4.70	6.32	8.66	11.57	14.38	16.37	16.34	14.21	10.90	7.18	4.75

641

642  
643  
644

Table 2 Values of basic variables used in the time-dependent non-uniform corrosion model

<b>Symbol</b>	<b>Values</b>	<b>Sources</b>
$D$	12 mm	Li [41]
$d_0$	0.0125 mm	Liu and Weyers [2]
$\alpha_{rust}$	0.57	Liu and Weyers [2]
$\rho_{rust}$	3.60 mg/mm <sup>3</sup>	Liu and Weyers [2]
$\rho_{st}$	7.85 mg/mm <sup>3</sup>	Liu and Weyers [2]
$W_{rust}$	mg	Liu and Weyers [2]
$w/c$	0.54	Jiang [27]
$Cl^-$	3.034%	Jiang [27]
$P$	0.68	Jiang [27]
$T_{t_1}$	289.36 K	Metoffice.uk[36]

645

Table 3 Values for geometric and mechanical parameters in cracking simulation

<b>Description</b>	<b>Symbol</b>	<b>Values</b>
Cover thickness	$C$	20 mm
Clear space of steel bars	$S$	30 mm
		45 mm
		60 mm
Diameter of steel bars	$D$	12 mm
Length of RC	$L$	178 mm
Height of RC	$H$	400 mm
Effective modulus of elasticity	$E_{ef}$	18.82 GPa [41]
Poisson's ratio	$\nu_c$	0.18 [41]
Shear modulus	$G$	$E/[2(1+\nu)]$ [42]
Tensile strength	$f_t'$	5.725 MPa [41]
Fracture energy	$G_f$	60 N/m [43, 44]
		90 N/m [43, 44]
		120 N/m [43, 44]

Table 4 Crack patterns and time to cracking for different values of fracture energy and reinforcement clear spacing

	$G_{f1}$							$G_{f2}$							$G_{f3}$						
	$P$	$t_{th1}$	$t_{th2}$	$t_{to1}$	$t_{to2}$	$t_{si1}$	$t_{si2}$	$P$	$t_{th1}$	$t_{th2}$	$t_{to1}$	$t_{to2}$	$t_{si1}$	$t_{si2}$	$P$	$t_{th1}$	$t_{th2}$	$t_{to1}$	$t_{to2}$	$t_{si1}$	$t_{si2}$
$S_1$	$De$	0.41	0.44	N/A	N/A	0.60	0.85	$De$	0.62	0.70	N/A	N/A	0.91	1.05	$Sp$	0.86	0.92	1.43	N/A	1.13	N/A
$S_2$	$Sp$	0.62	0.79	0.70	N/A	0.62	N/A	$Sp$	0.89	0.93	0.89	N/A	1.01	N/A	$Sp$	1.04	1.11	1.64	N/A	1.33	N/A
$S_3$	$Sp$	0.67	1.3	0.70	N/A	0.67	N/A	$Sp$	0.88	1.59	0.84	N/A	1.00	N/A	$Sp$	1.13	1.88	1.04	N/A	1.46	N/A
Parameter											Description or value										
$G_{f1}$											Fracture energy 60 N/m										
$G_{f2}$											Fracture energy 90 N/m										
$G_{f3}$											Fracture energy 120 N/m										
$S_1$											Spacing between rebars 30 mm										
$S_2$											Spacing between rebars 45 mm										
$S_3$											Spacing between rebars 60 mm										
$P$											Crack pattern										
$De$											Delamination										
$Sp$											Combined delamination and corner spalling										
$t_{th1}$											Time to initiation of through crack										
$t_{th2}$											Time to complete formation of through crack										
$t_{to1}$											Time to initiation of top crack										
$t_{to2}$											Time to complete formation of top crack										
$t_{si1}$											Time to initiation of side crack										
$t_{si2}$											Time to complete formation of side crack										
Time unit											year										

Table 5 Values for basic variables used for validation

<b>Description</b>	<b>Symbol</b>	<b>Values</b>
Top cover thickness	$C_T$	20 mm
Edge cover thickness	$C_E$	75 mm
Space of steel bars	$S$	150 mm
Diameter of steel bars	$D$	12 mm
Length of RC	$L$	648 mm
Height of RC	$H$	400 mm
Effective modulus of elasticity	$E_{ef}$	18.82 GPa
Poisson's ratio	$\nu_c$	0.18
Tension strength	$f_t'$	2.4 MPa
Fracture energy	$G_f$	65 N/m
Corrosion rate	$i_{corr}$	100 $\mu\text{A}/\text{cm}^2$

653

## LIST OF FIGURES

- 654 1. Non-uniform corrosion model
- 655 2. Time-dependent corrosion rate in the whole life-cycle of RC structures
- 656 3. Constitutive relationship of concrete in tension for Mode-I fracture
- 657 4. Insertion process of cohesive elements: (a) initial mesh; (b) inserted cohesive element  
658 based on newly created nodes; and (c) mesh after insertion of cohesive elements
- 659 5. Configuration of the RC beam with multiple tension bars
- 660 6. Typical meshing for half of the cover structure modelled
- 661 7. Time-dependent corrosion rate from corrosion initiation by considering seasoned effect
- 662 8. Development of  $d_m(t)$  as a function of time under various corrosion rates
- 663 9. Two typical cracking patterns for half of RC structures
- 664 10. Experimental verification of the crack width
- 665 11. The maximum principal stress distributions around the corner rebar under (a) uniform  
666 corrosion and (b) non-uniform corrosion
- 667 12. Normal (driving) stress distributions of (a) side crack and (b) top crack prior to cracking  
668 initiation
- 669 13. Time to surface cracking (top crack) as a function of corrosion rate
- 670 14. Time to surface cracking (top crack) as a function of ambient temperature
- 671 15. Time to surface cracking (top crack) as a function of chloride-ion content
- 672 16. Surface crack width (top crack) as a function of time under various corrosion rates
- 673 17. Surface crack width (side crack) as a function of time for different fracture energies of  
674 concrete
- 675 18. Surface crack width (top crack) as a function of time for different fracture energies of  
676 concrete
- 677 19. Surface crack width (top crack) as a function of time for different reinforcement spacing
- 678 20. Effect of fracture energy and spacing on time to cracking

679 21. Normal stress distributions along the side crack

680 22. Normal stress distributions along the top crack

681

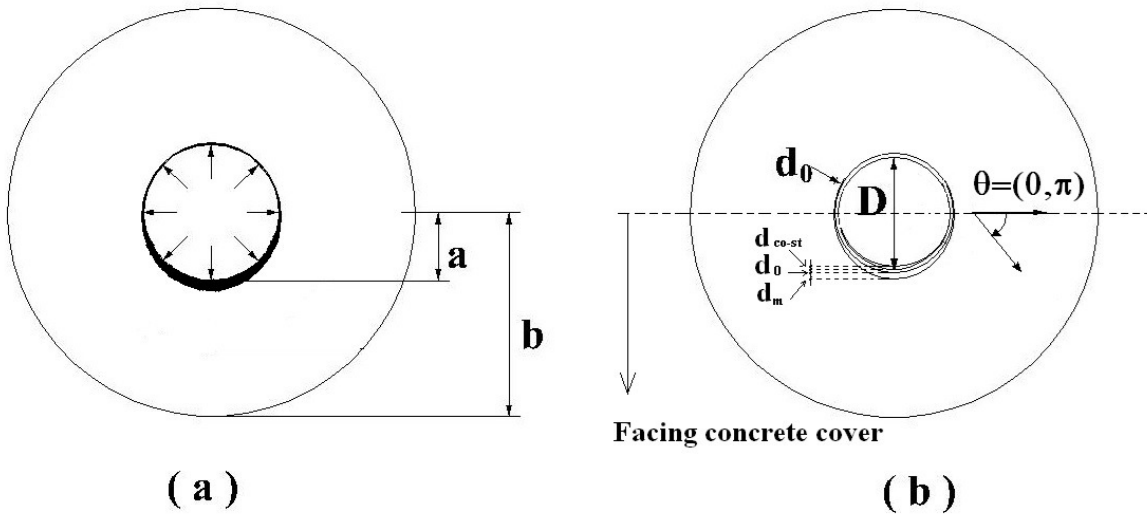

682

683

Figure 1 Non-uniform corrosion model

684

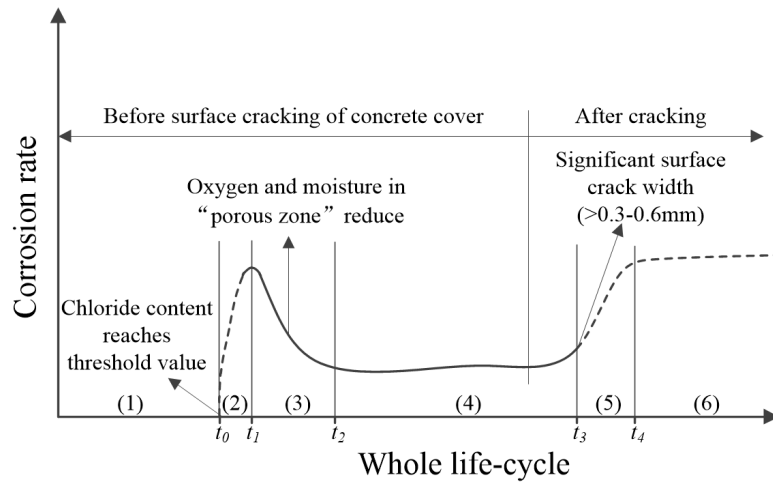

685

686

Figure 2 Time-dependent corrosion rate in the whole life-cycle of RC structures

687

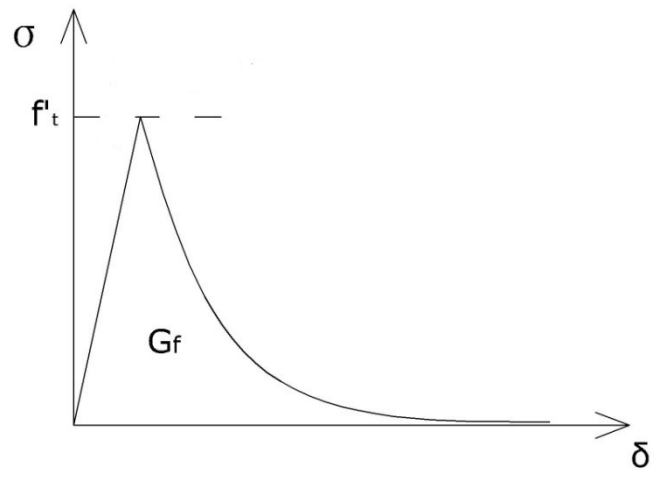

688

689

Figure 3 Constitutive relationship of concrete in tension for Mode-I fracture

690

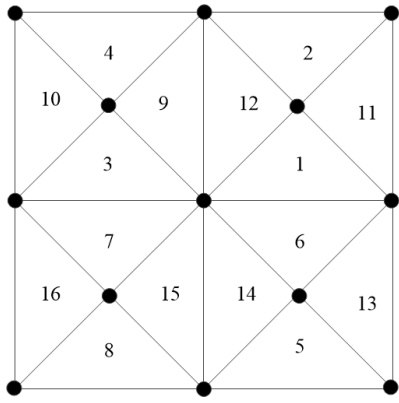

(a)

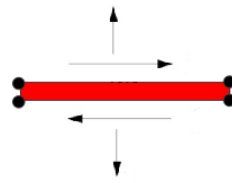

(b)

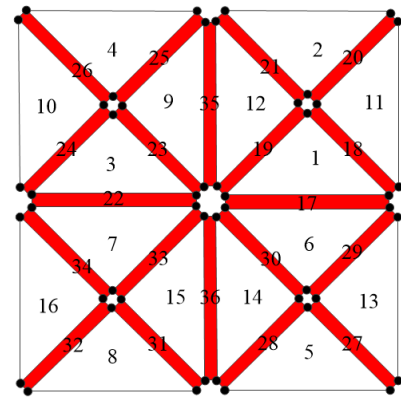

(c)

691

692

693

694

Figure 4 Insertion process of cohesive elements: (a) initial mesh; (b) inserted cohesive

695

element based on newly created nodes; and (c) mesh after insertion of cohesive elements

696

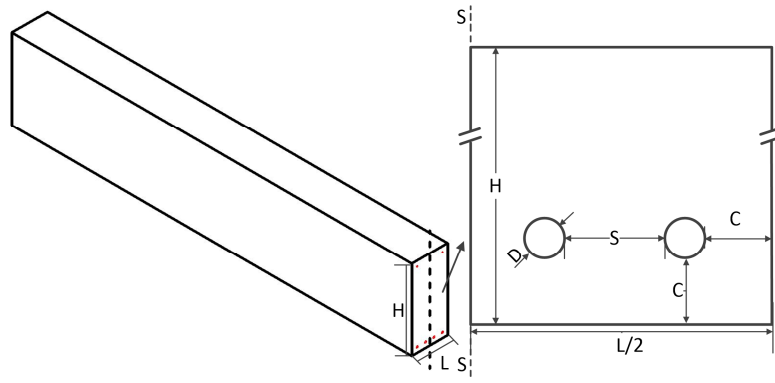

697

698

Figure 5 Configuration of the RC beam with multiple tension bars

699

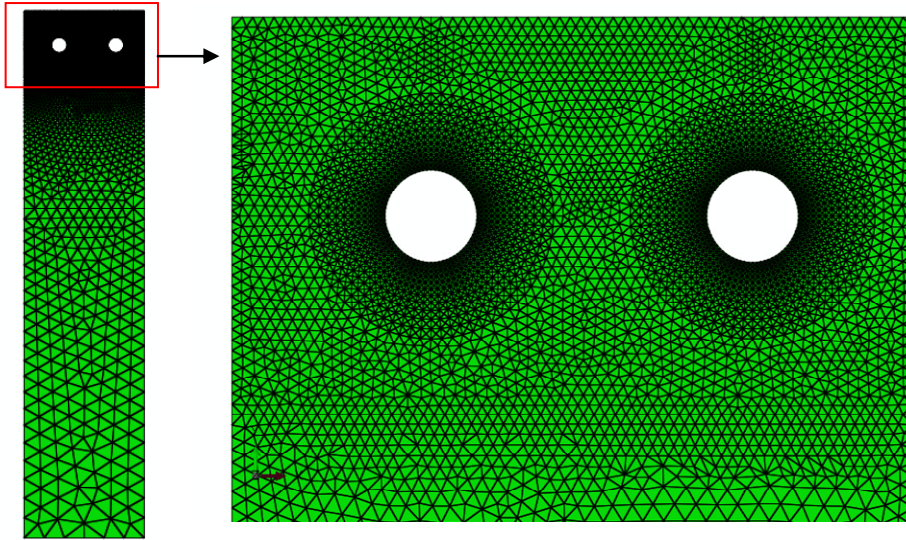

700

701

Figure 6 Typical meshing for half of the cover structure modelled

702

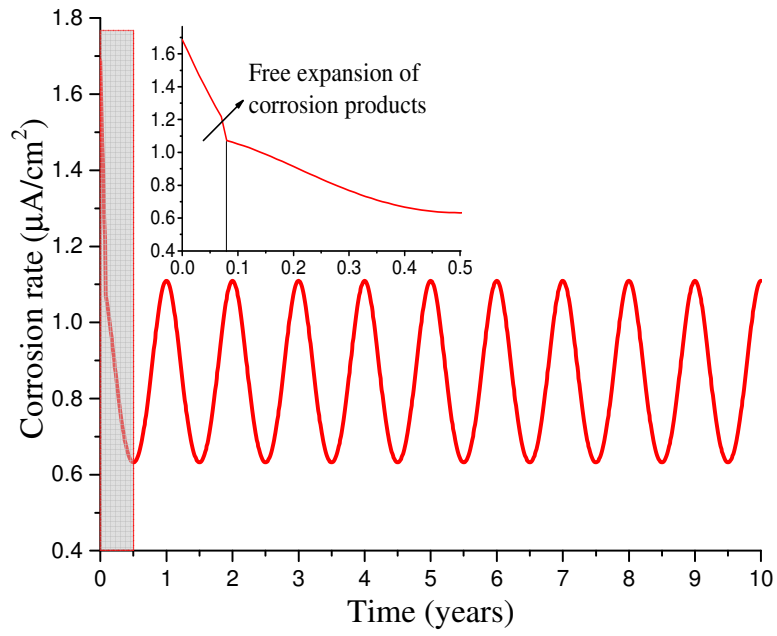

703

704 Figure 7 Time-dependent corrosion rate from corrosion initiation by considering seasoned

705 effect

706

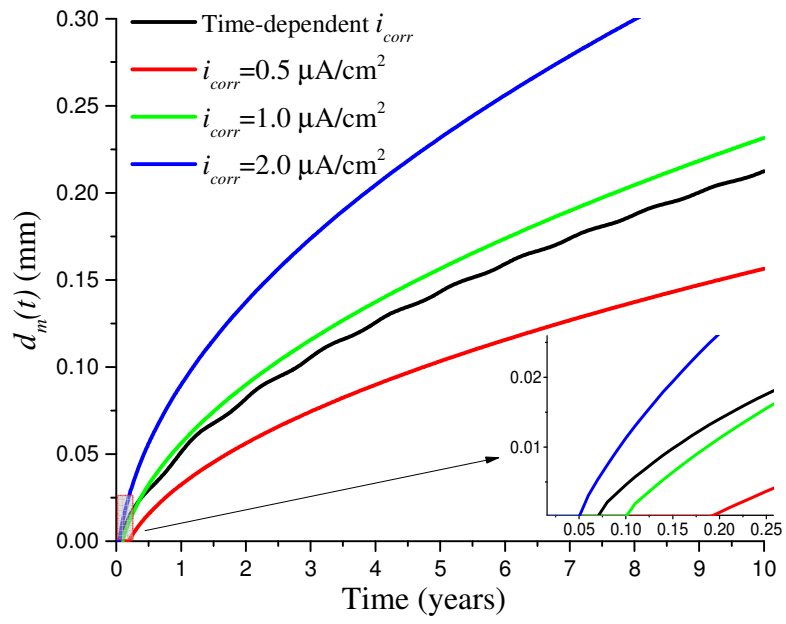

707

708

Figure 8 Development of  $d_m(t)$  as a function of time under various corrosion rates

709

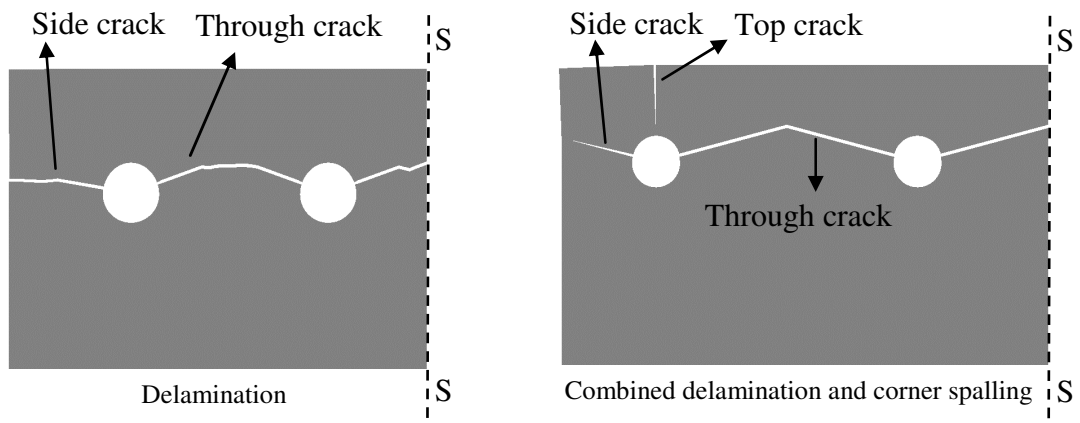

710

711

Figure 9 Two typical cracking patterns for half of RC structures

712

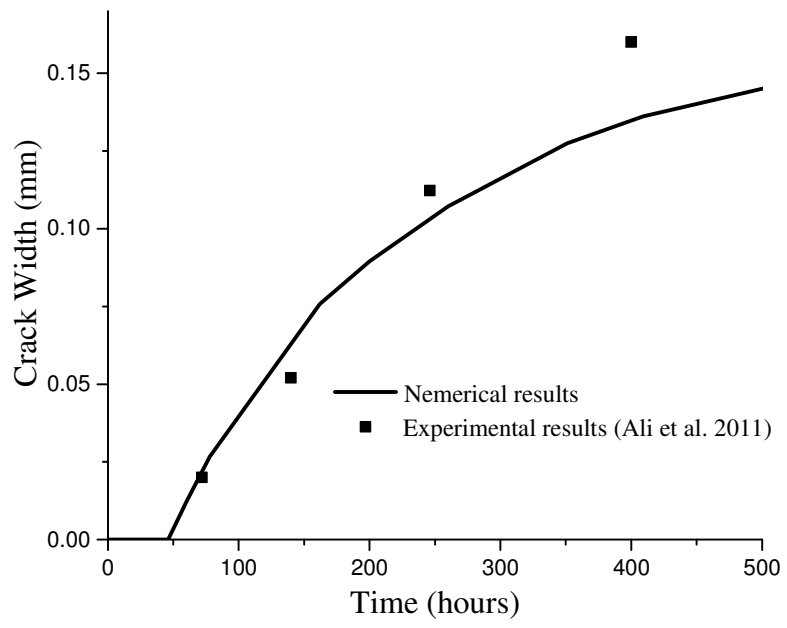

713

714

Figure 10 Experimental verification of the crack width

715

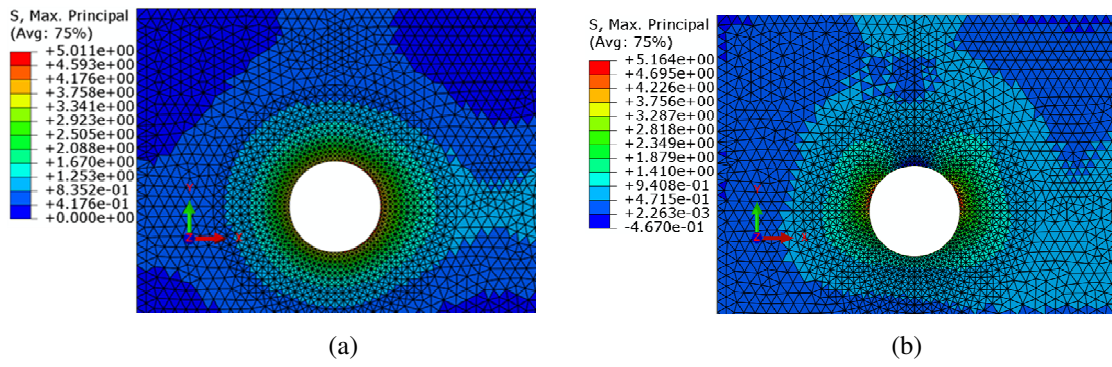

716

717

718 Figure 11 The maximum principal stress distributions around the corner rebar under (a)

719

uniform corrosion and (b) non-uniform corrosion

720

721

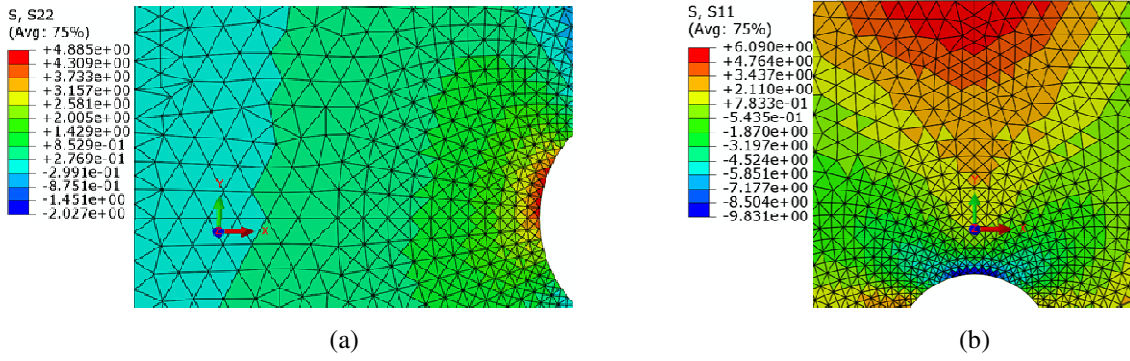

722

723

724

Figure 12 Normal (driving) stress distributions of (a) side crack and (b) top crack prior to

725

cracking initiation

726

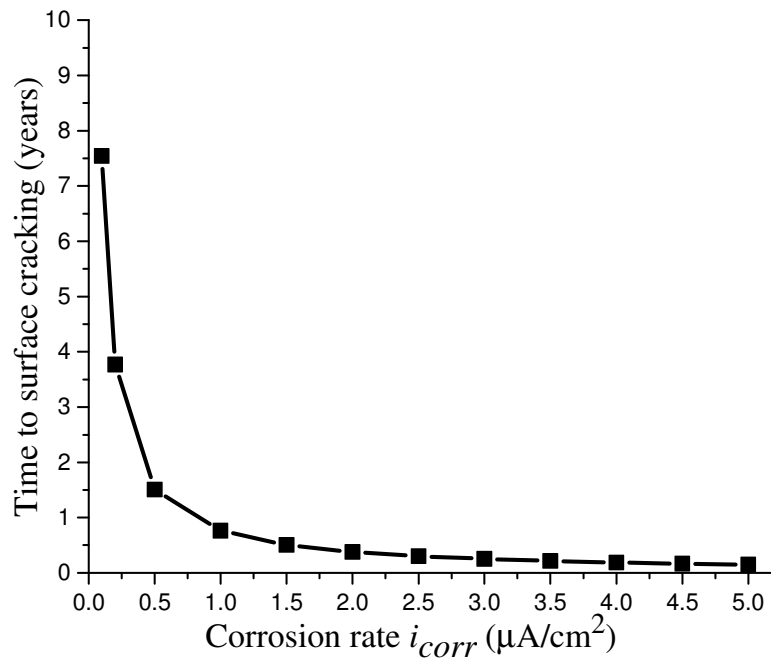

727

728

Figure 13 Time to surface cracking (top crack) as a function of corrosion rate

729

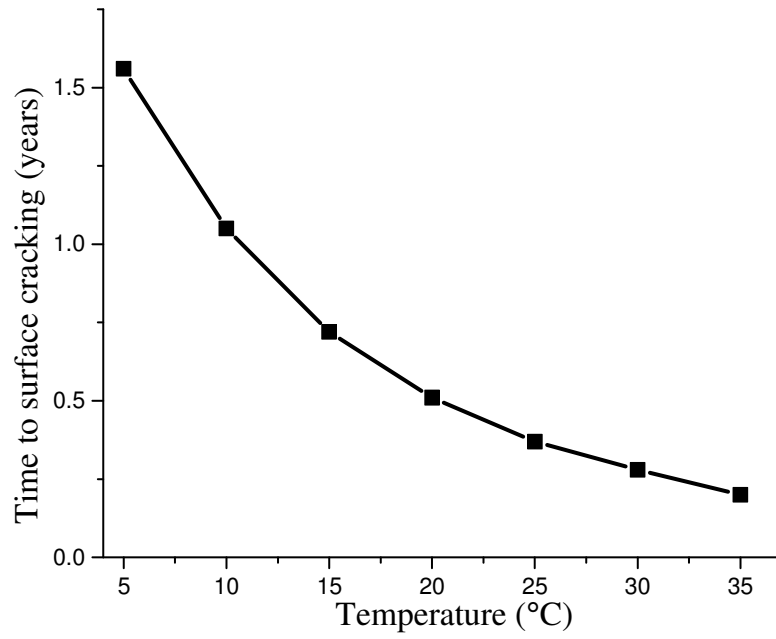

730

731

Figure 14 Time to surface cracking (top crack) as a function of ambient temperature

732

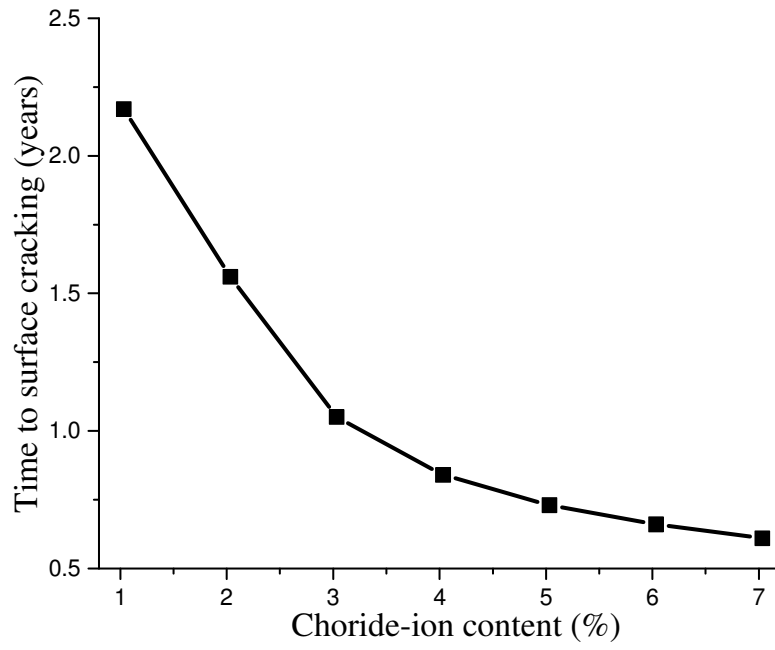

733

734

Figure 15 Time to surface cracking (top crack) as a function of chloride-ion content

735

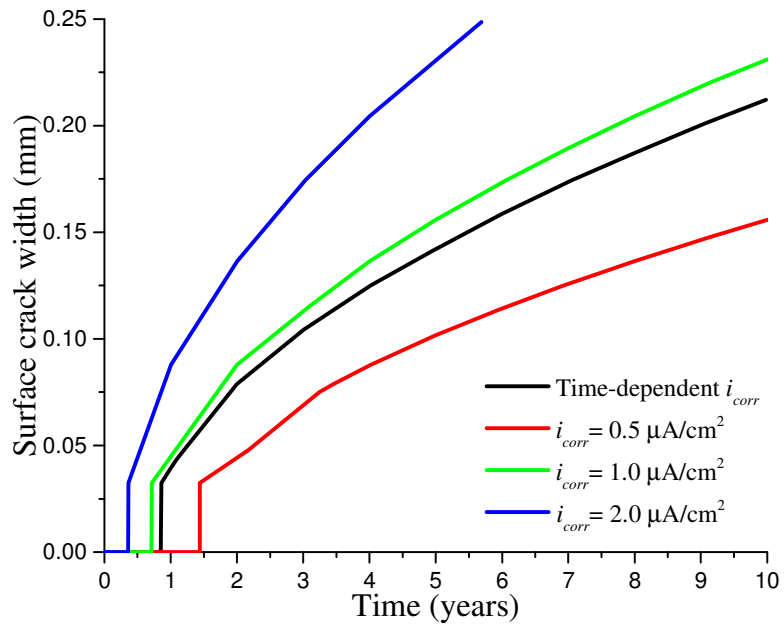

736

737 Figure 16 Surface crack width (top crack) as a function of time under various corrosion rates

738

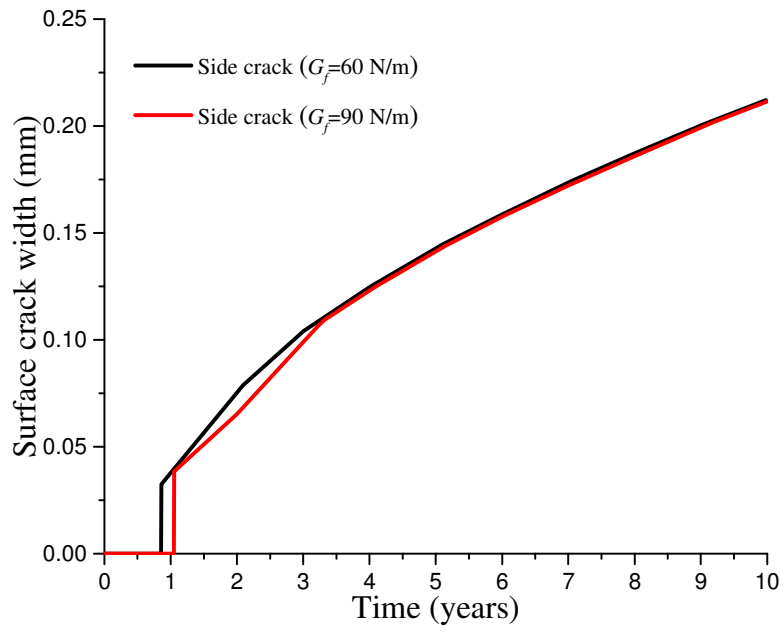

739

740 Figure 17 Surface crack width (side crack) as a function of time for different fracture energies

741

of concrete

742

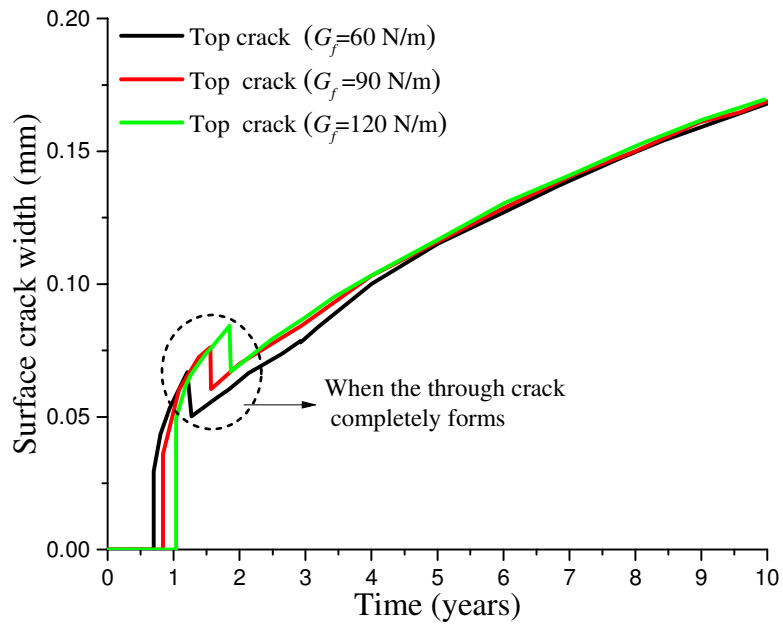

743

744 Figure 18 Surface crack width (top crack) as a function of time for different fracture energies

745

of concrete

746

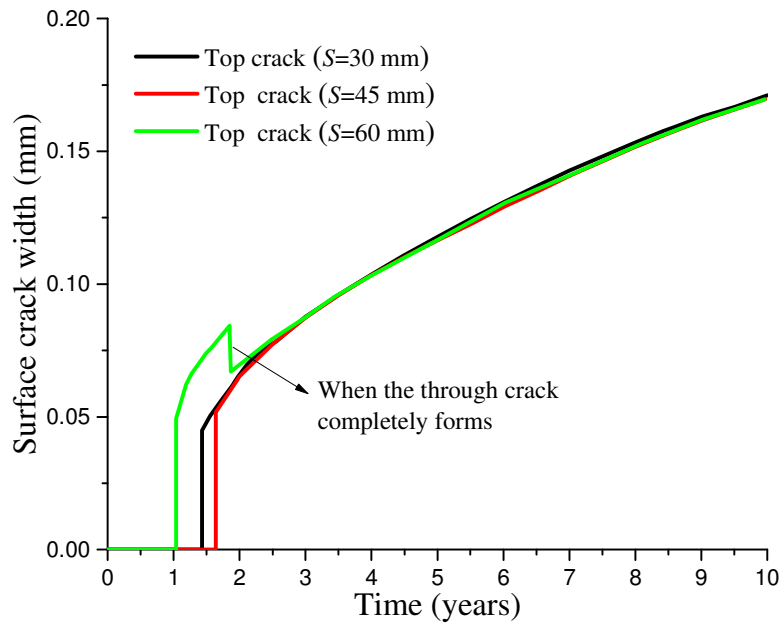

747

748 Figure 19 Surface crack width (top crack) as a function of time for different reinforcement  
 749 spacing

750

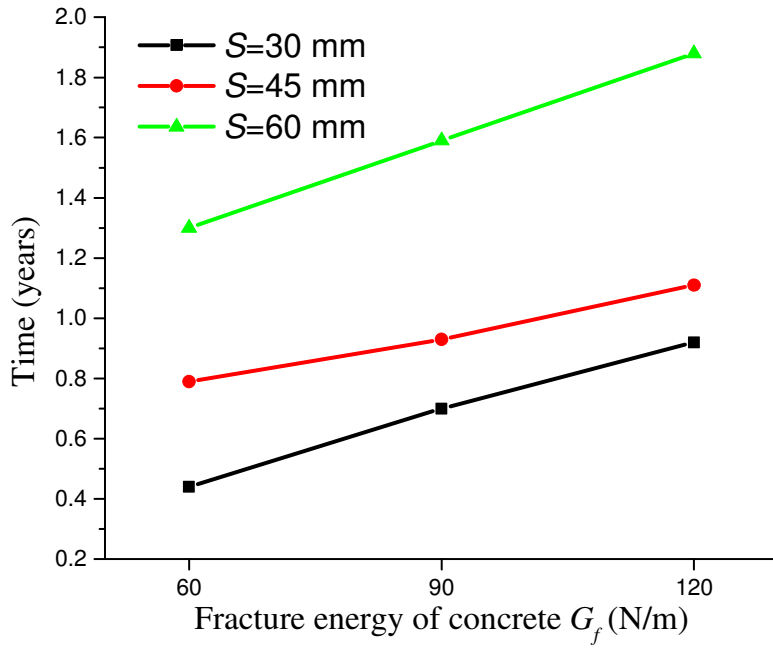

(a) Time to complete formation of through crack

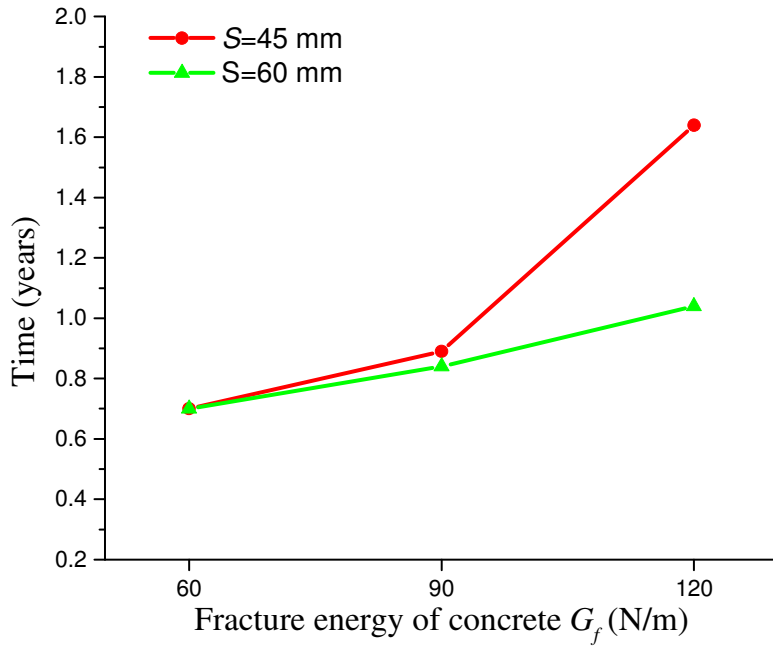

(b) Time to initiation of top surface crack

Figure 20 Effect of fracture energy and spacing on time to cracking

751  
752

753  
754  
755  
756

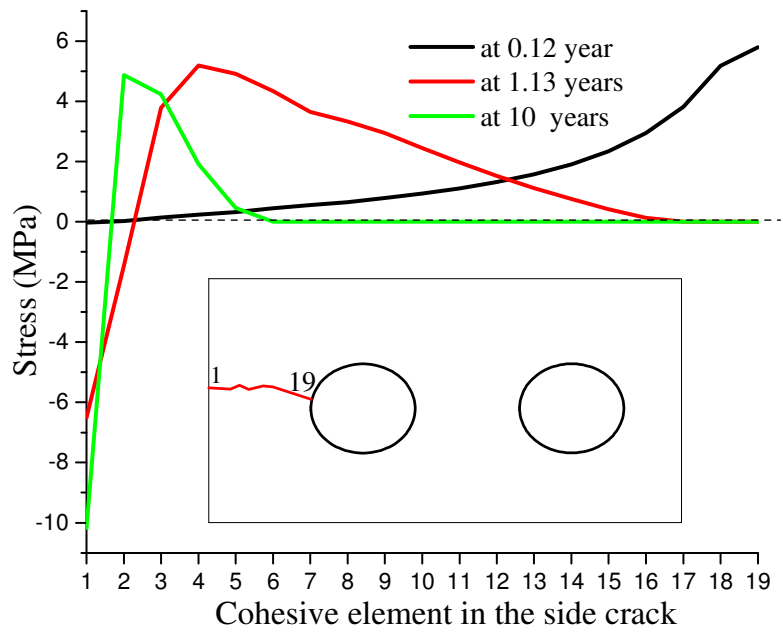

757

758

759

Figure 21 Normal stress distributions along the side crack

760

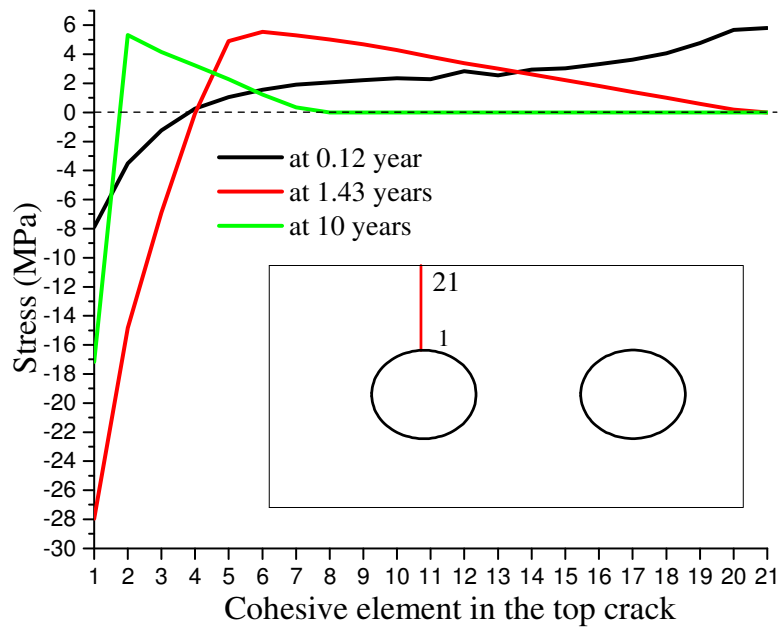

761

762

Figure 22 Normal stress distributions along the top crack

763