

# **Integrated Building Performance Simulation**

**J A Clarke**  
**ESRU, University of Strathclyde**  
**joe@esru.strath.ac.uk**

## **ABSTRACT**

This paper justifies the need for an integrated approach to building performance assessment and provides examples of the technical appraisals that may then be enabled. The contention is that the use of design tools which focus on a single domain will result in sub-optimum design solutions in terms of indoor air quality, occupant comfort, energy use and environmental impact.

## **INTRODUCTION**

Energy efficiency may be likened to an untapped, clean energy resource of vast potential. The barrier to accessing this resource is less to do with technological constraints—much know-how and many approaches already exist—and more to do with ineffective decision-support. It is a strange paradox that in the age of IT information is never in the hands of those who need it to make informed decisions.

It is in response to this deficiency that building simulation has evolved for use to appraise options for change in terms of relevant issues such as human health and comfort, energy demand reduction and sustainable practices. Because of the growing acceptance that simulation defines best practice, substantial attempts are being made to transfer the technology into practice (Bartholomew *et al* 1997, McElroy and Clarke 1999).

## **INTEGRATED PERFORMANCE SIMULATION**

The aim of integrated modelling is to preserve the integrity of the building/plant system by simultaneously processing all energy transport paths at a level of detail commensurate with the objectives of the problem in hand and the uncertainties inherent in the describing data. To this end, a building should be regarded as being systemic (many parts make the whole), dynamic (the parts evolve at different rates), non-linear (the parameters depend on the thermodynamic state) and, above all, complex (there are myriad intra- and inter-part interactions). To achieve high modelling integrity, a simulation program aims to preserve these intrinsic characteristics.

Interface issues aside, it is surely more appropriate to use an integrated simulation program throughout the design process than to use a progression of tools—from simplified to detailed—and ignore the many theoretical discontinuities and pernicious assumptions.

This paper describes the appraisals enabled by integrated simulation. The mathematical modelling aspects of the approach are described in detail elsewhere (Clarke 2001).

## USE IN PRACTICE

Applying simulation to the design and management of the built environment represents a paradigm shift of unparalleled scale. For the first time, the construction industry has the means to address the underlying thermodynamic complexities and undertake integrated performance appraisals of options at reasonable cost.

Within the integrated approach, as summarised in Table 1, behaviour follows description (or, in other words, reward follows effort). This means that significant decision support can often be achieved for little input effort. It also means that more detail can be added to a model as the design hypothesis progresses and the complexity of the domain interactions grow.

Table 1: Mapping of problem description to model behaviour.

Cumulative model description	Typical behaviour enabled
pre-existing databases	simple performance indicators (e.g. material behaviour);
+ geometry	visualisation, photomontage, shading, insolation etc;
+ constructional attribution	material quantities, embodied energy, etc;
+ operational attribution	casual gains, electricity demands etc;
+ boundary conditions	photo-realistic imaging, illuminance distribution, no-systems thermal and visual comfort levels etc;
+ special materials	photovoltaics and switchable glazings evaluation etc;
+ control system	daylight utilisation, energy use, system response etc;
+ flow network	ventilation and heat recovery evaluation etc;
+ HVAC network	psychrometric analysis, component sizing etc;
+ CFD domain	indoor air quality, thermal comfort etc;
+ electrical power network	renewable energy integration, load control etc;
+ enhanced resolution	thermal bridging etc;
+ moisture network	local condensation, mould growth and health.

Consider the following scenario, the purpose of which is to highlight the integrated appraisal process and, by implication, indicate the nature of a possible future design activity. This scenario employs the ESP-r system <<http://www.esru.strath.ac.uk>> when its underlying data model is cumulatively refined according to the process of Table 1.

A Project Manager module (Hand 1998) gives access to support databases, a simulation engine, performance assessment tools and a variety of third party applications for CABD, visualisation, report generation etc. Its function is to co-ordinate problem definition and give/receive the data model to/from the simulation engine when the design hypothesis changes. Significantly, it supports an incremental evolution of the problem definition, giving access to the simulator's corresponding functionality at each stage.

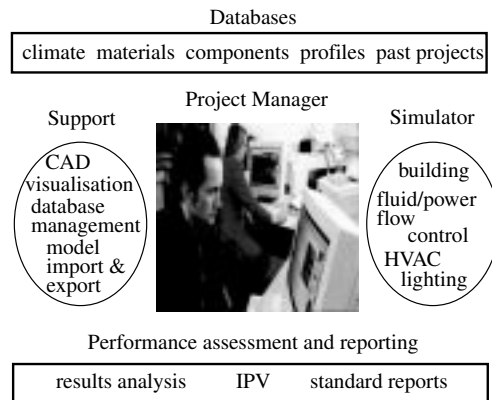

The starting point for a new project is to scrutinise and make ready the support databases. These include hygro-thermal, embodied energy and optical properties for construction elements and composites, typical occupancy profiles, pressure coefficient sets for use in problems involving air flow modelling, plant components for use in HVAC systems modelling, mould species data for use with predicted local surface conditions to assess the risk of mould growth, and climate collections.

Embedded within such databases is knowledge that might usefully support the design conceptualisation process. As an example, the construction elements database will contain sets of fundamental hygro-thermo and optical properties for a range of construction materials, and derived properties from which behaviour may be deduced (e.g. the use of thermal diffusivity to characterise the rate of response or the thermal transmittance to characterise the rate of heat loss).

Although the procedure for problem definition is largely a matter of personal preference, it is not uncommon to commence the process with the specification of a building's geometry using a CABD tool. ESP-r can inter-operate with CAD tools such as AutoCAD, which can be used to create a building model of arbitrary complexity. This model can then be imported to the Project Manager where the attribution process is enabled.

Simple wireline or false coloured images can then be generated as an aid to the communication of design intent or the study of solar/daylight access. The Project Manager provides wireframe photomontages and coloured, textured images via the Radiance system (Larson and Shakespeare 1998). In the latter case the required input model is automatically generating and Radiance is invoked and controlled by ESP-r.

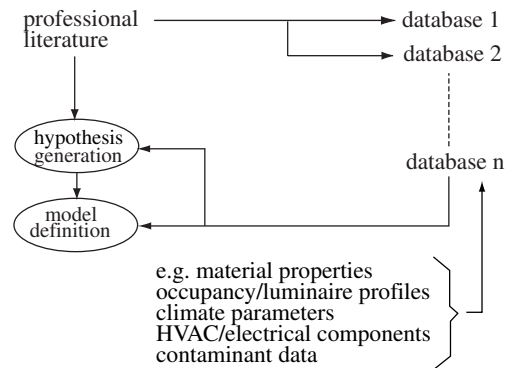

fundamental:	<ul style="list-style-type: none"> <li>conductivity</li> <li>density</li> <li>specific heat</li> <li>transmissivity</li> <li>reflectivity</li> <li>vapour diffusivity</li> <li>surface absorptivity</li> <li>surface emissivity</li> </ul>
derived:	<ul style="list-style-type: none"> <li>thermal transmissivity</li> <li>thermal diffusivity</li> <li>thermal effusivity</li> </ul>

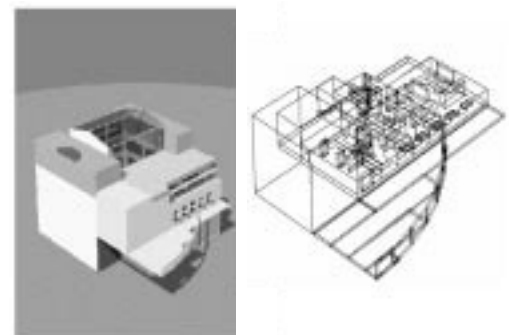

Constructional and operational attribution is now achieved by selecting products (e.g. wall constructions) and entities (e.g. occupancy profiles) from the support databases and associating these with the geometrical entities previously defined. It is at this stage that the simulation novice will appreciate the importance of a well conceived problem abstraction, which achieves an adequate resolution while minimising the number of entities requiring attribution, simulation processing and performance appraisal. Problem abstraction is an acquired skill that develops over time.

Temperature, wind, radiation and luminance boundary conditions of the required severity are now associated with the model to enable an appraisal of environmental performance—e.g. thermal and visual comfort levels throughout the year—and to gain an insight into the extent of any required remedial action. As appropriate, these boundary conditions can be modified to represent extreme weather events or local micro-climate phenomena.

As required, geometrical, constructional or operational changes can be applied to the model in order to determine the impact on performance. For example, alternative constructional systems might be investigated, different occupancy loadings imposed, or different approaches to daylight utilisation assessed along with the extent and location of glare as shown here for the case of an office with added light shelf. The possibilities are limited only by the designer’s imagination.

Special facade systems might now be considered: PV components to transform part of the solar power spectrum into electricity (and heat); transparent insulation to capture passively and process solar energy, or adaptable glazings to control glare and/or solar gain. In each case, the contribution to improved environmental performance and reduced energy use can be determined. It is even possible to study ways to eliminate conflict as in the case of a PV facade reducing daylight penetration to the interior.

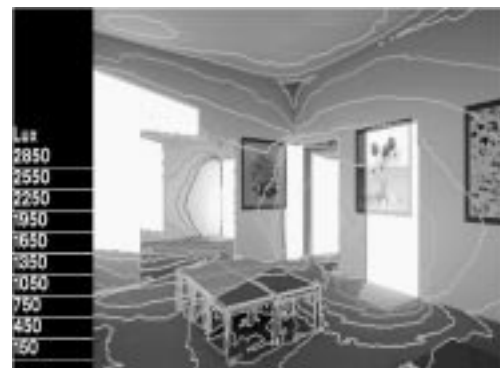
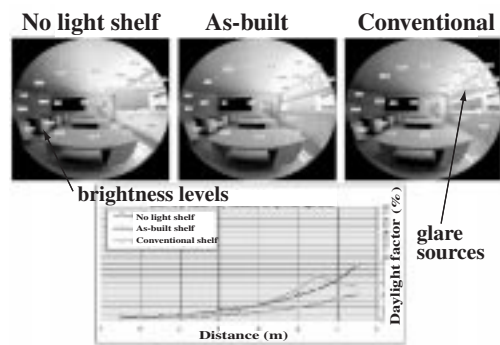
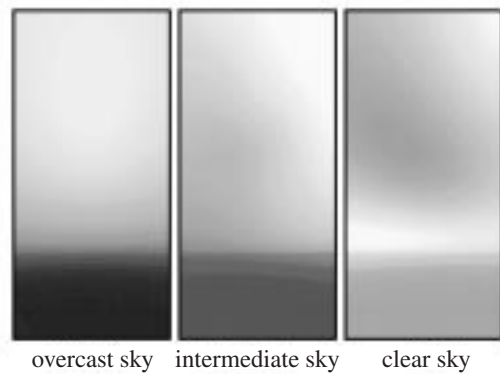
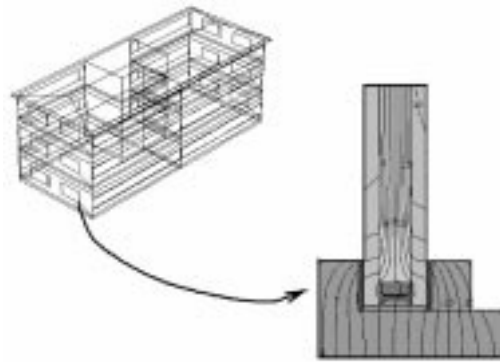

To access the energy displacement potential of this daylight, a luminaire control system might now be introduced, comprising one or more photocells linked to a circuit switch or luminaire dimming device. Subsequent simulations can then be undertaken to optimise the parameters of this control system in an attempt to maximise the displacement of the electricity required for lighting purposes. In this way, the conflict that exists between the beneficial aspects of daylight capture and the detrimental effects of the reduced heat gain from lights (on heating load) can be studied.

The issue of integrated environmental control can now be explored by establishing a control system conceived as a collection of open or closed loops. Some of these loops will dictate the availability of heating, cooling, ventilation, lighting etc, while others will serve only to resolve conflict between these delivery systems. Previous aspects of the model may now be revisited in order to change the building's dynamic response to accommodate the intended control action.

To study the feasibility of natural ventilation, a flow network can be associated with the building model so that the dynamic interactions are represented. The control definition may then be extended to include actions applied to the network components—e.g. to emulate window opening or flow damper control. This model can be used to examine the impact on air flow of alternative assumptions applied to the distributed leakage paths. In this way robust natural or mixed mode ventilation schemes may be designed.

Where mechanical intervention is required, a component network can be defined to represent the HVAC system for association with both the building model and any active flow network. The control definition previously established may be further extended to provide internal component control and link the room states to the supply condition. Such a model can be used to study the operational characteristics of the overall plant system or its component parts.

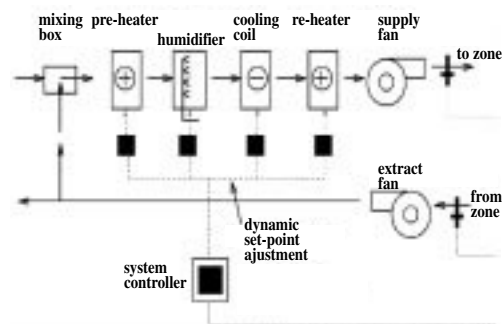
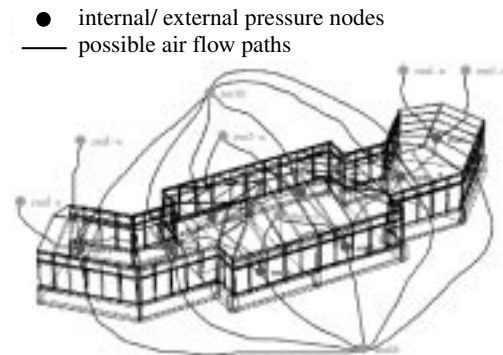
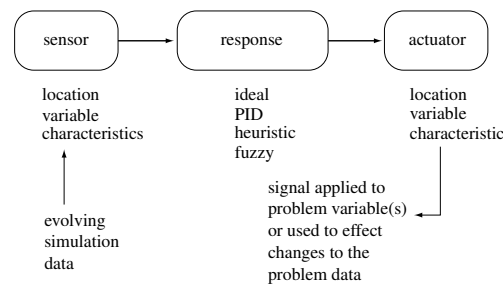
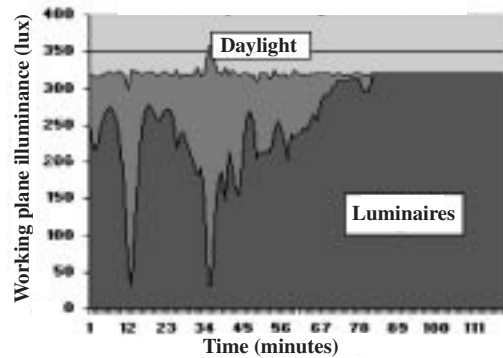

In order to examine indoor air quality, spaces within the building model can be discretised to allow the use of CFD to evaluate the intra-space air movement and the distribution of temperature, humidity and species concentration. These data may then be combined to determine the comfort levels and air quality at different points within the space. A useful determinant of indoor air quality is the distribution of the mean age of air.

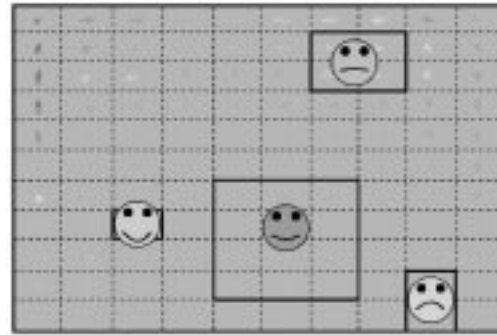

While the components of a model—the building, flow and HVAC networks, and the CFD domain—may be processed independently, it is usual to subject them to an integrated assessment whereby the dynamic interactions are explicitly represented. In the example shown here, a house model has been assigned a flow network to represent natural ventilation, an HVAC network to represent a ventilation heat recovery system, a CFD domain to enable the detailed analysis of air quality and a moisture flow model to allow an accurate assessment of humidity distribution.

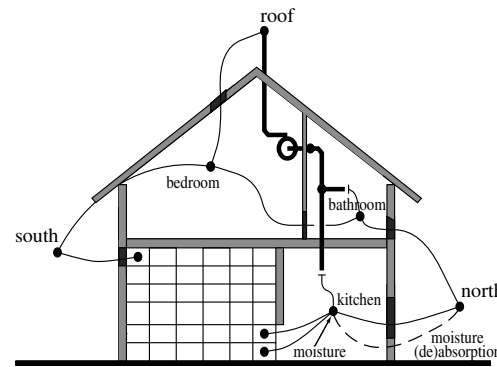

A further network might now be added to represent the building's electrical power circuits. This can be used in conjunction with the previously established models for facade-integrated photovoltaics, luminaire control, HVAC and flow networks to study scenarios for the local utilisation of the outputs from building-integrated renewable energy components, the co-operative switching with the public electricity supply and the shedding of load as an energy efficiency measure. Other technologies, such as combined heat and power plant and fuel cells, can also be assessed.

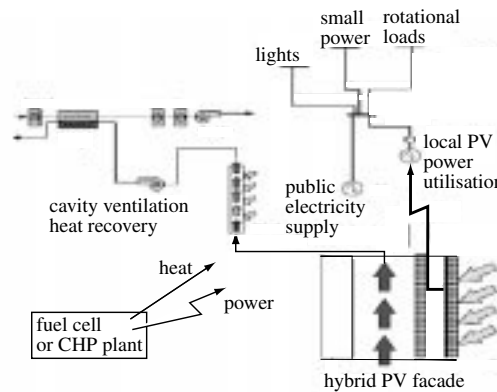

For specialist applications, the resolution of parts of the model can now be selectively enhanced to allow the detailed study of particular issues. For example, a portion of a multi-layered construction might be finely discretised to enable the study of the behaviour of a thermal bridge or innovative building component. A moisture flow network might then be added to support an assessment of the potential for interstitial or surface condensation.

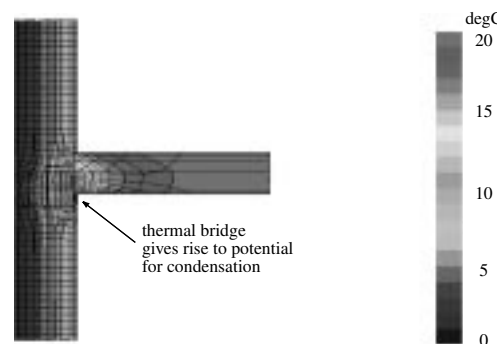



By associating the time series pairs of near surface temperature and relative humidity (to emerge from the integrated building, CFD and network air/moisture flow models) with the growth limit data as held in the mould species database, it is possible to determine the risk of mould growth and explore the different possible remedial actions—from eliminating moisture at source to modifying the constructional material or arrangement in order to prevent optimum growth conditions from occurring in the first place.

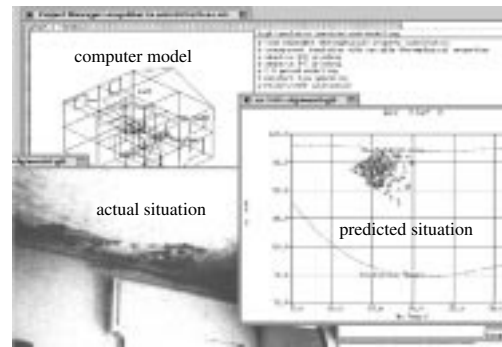

The Project Manager requires that a record be kept of the problem composition and to this end is able to store and manipulate text and images. At any stage the results for the different aspects of performance may be presented in the form of an Integrated Performance View that quantifies issues such as seasonal fuel use, environmental emissions, thermal/visual/acoustic comfort, daylight utilisation, risk of condensation, renewable energy contribution etc.

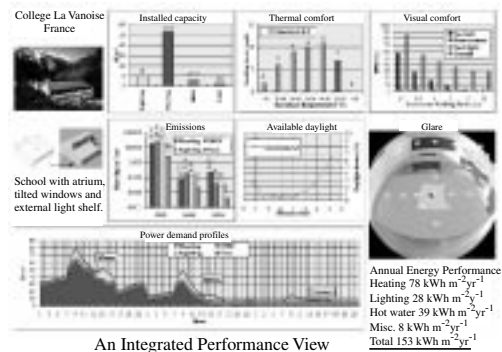

The core message is that any problem—from a single space with simple control and prescribed ventilation, to an entire building with systems, distributed control and enhanced resolutions—can be passed to the Simulator where its multi-variate performance is assessed and made available to inform the process of design evolution. By integrating the different technical domains, the approach supports the identification of appropriate trade-offs.

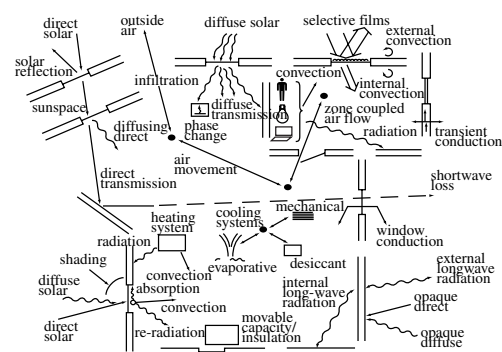

Importantly, integrated modelling supports team working because it provides a mechanism whereby the different professional viewpoints can come together and contribute equally to the eventual outcome. Moreover, given the electronic form of the underlying model, and the possibility of efficiently updating this model as the design hypothesis evolves, the different members of the team may operate from different locations and within different time zones. Such an inter-disciplinary approach is likely to give rise to more sustainable solutions.

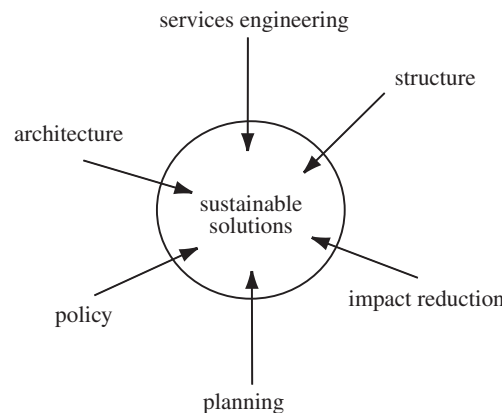

At the present time work is underway to add a life cycle impact assessment (LCIA) procedure to the ESP-r system (Citherlet *et al* 2001). This supports the assessment of the energy use and environmental emissions relating to the manufacture, transport, assembly, maintenance and disposal of construction materials.

## PERFORMANCE ASSESSMENT METHOD

To achieve effective application in practice, a performance assessment method (PAM) is required to direct the user's line of inquiry. Table 2 shows the stages of a generic PAM in which the action required at each stage is underlined and the knowledge required to implement this action is shown in *italics*.

Table 2: A generic PAM for building energy simulation.

Stage	Activity
1	<u>Establish a computer representation</u> corresponding to a <i>base case design</i> .
2	<u>Calibrate this model</u> using <i>reliable techniques</i> .
3	<u>Locate representative boundary conditions</u> of <i>appropriate severity</i> .
4	<u>Undertake integrated simulations</u> using <i>suitable applications</i> .
5	<u>Express multi-variate performance</u> in terms of <i>suitable criteria</i> .
6	<u>Identify problem areas</u> as a function of <i>criteria acceptability</i> .
7	<u>Analyse simulation results</u> to identify <i>cause of problems</i> .
8	<u>Postulate remedies</u> by associating causes with <i>appropriate design options</i> .
9	For each postulate, <u>establish a reference model</u> to a <i>justifiable level of resolution</i> .
10	<u>Iterate from step 4</u> until the overall performance is <i>satisfactory</i> .
11	<u>Repeat from step 3</u> to establish replicability for other <i>weather conditions</i> (where applicable).

Such a PAM can be attributed with alternative knowledge instances depending on the user's viewpoint, the application topic(s) and the program's capabilities. To illustrate the approach, consider the embedding of renewable energy systems within the Lighthouse Building in Glasgow (Clarke *et al* 2000). This project employed the integrated modelling approach to determine the best possible match between energy demand and the local renewable energy resource without compromising power quality.

A base case model, compliant with best practice, was established and its multi-variate performance determined against relevant weather conditions. A number of energy efficiency measures were then applied to the model (initially independently and then, where warranted, jointly) to determine their potential to reduce energy demand and alter the demand profile to accommodate the integration of active renewable components.

Figure 1 shows the cumulative impact of several measures: advanced glazing, daylight responsive luminaire control, facade-integrated transparent insulation, efficient lighting and dynamic heating set-point temperature control. When compared with the original design, these measures resulted in a 68% reduction in annual energy demand (corresponding to a 58% reduction in heating and an 80% reduction in lighting). More significantly, the final demand profiles were better matched to the output from locally deployed renewable energy systems: a



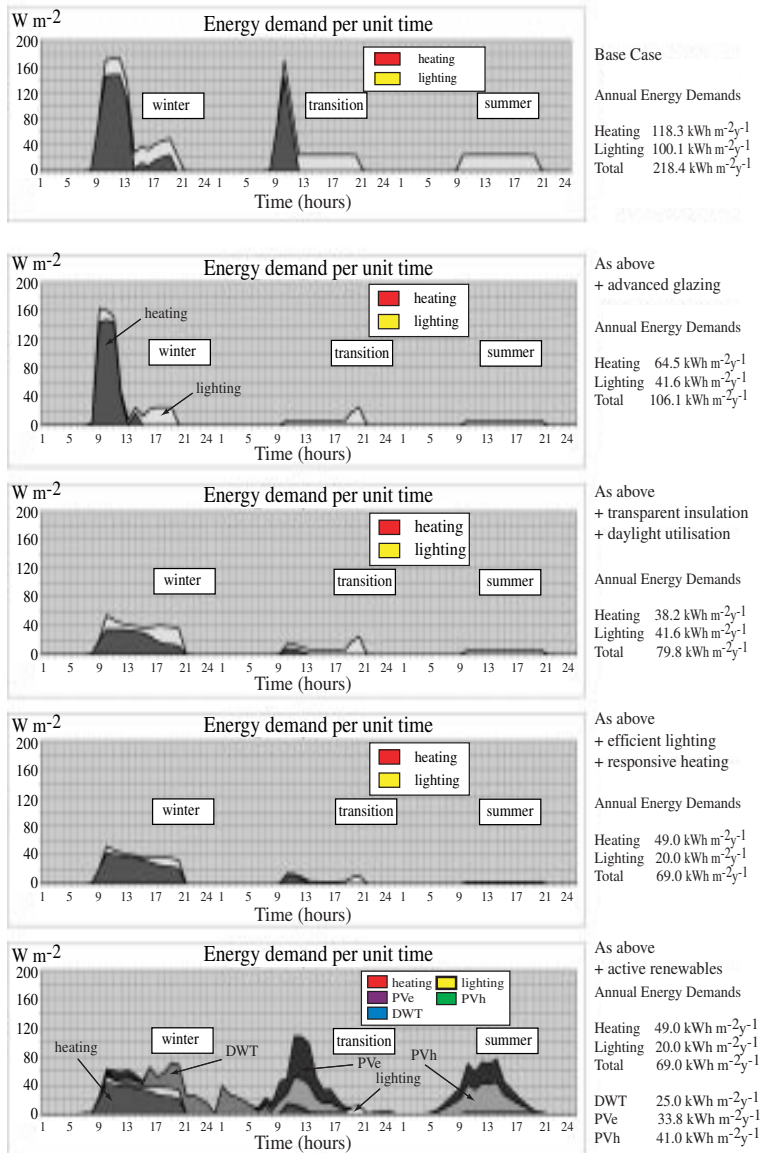

Figure 1: Energy efficiency facilitating RE component introduction.

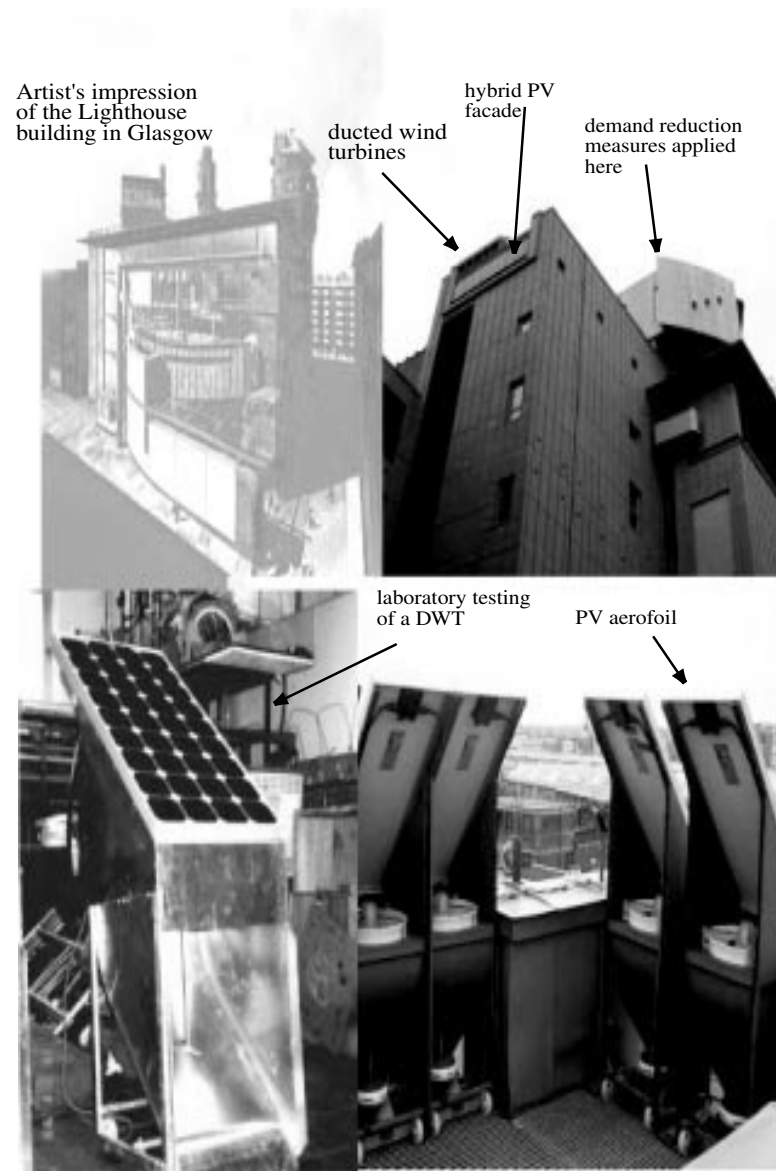

Figure 2: RE components as incorporated in the Lighthouse building in Glasgow

photovoltaic (PV) component operating in hybrid mode to provide both power and heat; and ducted wind turbines (DWT) with an integral photovoltaic aerofoil section to increase the output power density (Grant and Dannecker 2000). Also shown in Figure 1 is the predicted power outputs from these two RE technologies superimposed on the most favourable demand profile.

As shown in Figure 2, the hybrid PV component was subsequently incorporated within a south-facing facade of the Lighthouse building, while the DWTs were mounted on the south- and west-facing edges of the roof.

The appraisal possibilities are effectively without limit. The integrated simulation approach is as applicable to conversion as it is to new build. It may be used to inform the planning and resource allocation process. And it may be used to study innovative approaches such as the deployment of micro power systems within the built environment. With the proliferation of powerful, low cost computing, it is even possible to incorporate integrated simulation within a building's control system. Weather data and spatial requirements are fed to an explicit building/plant model which then anticipates the consequences of any proposed control action. In this way the control system is endowed with a predictive capability and so is able to take corrective action in advance.

## CONCLUSIONS

This paper has described the new appraisal possibilities that are being enabled by the emergence of simulation programs which are able to address the different domains that impact on a building's multi-variate performance. The challenge that remains is to embed the technology within the real time, real scale, resource constrained context of design practice. Meeting such a challenge may be seen as a significant contribution to planning for sustainable development.

## REFERENCES

- Bartholomew D, Hand J, Irving S, Lomas K, McElroy L B, Parand F, Robinson D and Strachan P 1997 An Application Manual for Building Energy and Environmental Modelling *Proc. Building Simulation '97* (Prague)
- Citherlet S, Clarke J A and Hand J 2001 Integration in Building Physics Simulation *Energy and Buildings* **33**(5) 451-61
- Clarke J A 2001 *Energy Simulation in Building Design (2nd Edn)* (Butterworth-Heinemann)
- Clarke J A, Johnstone C M, Macdonald I A, French P, Gillan S, Glover C, Tatton D, Devlin J and Mann R 2000 The Deployment of Photovoltaic Components Within the Lighthouse Building in Glasgow *Proc. 16th European Photovoltaic Solar Energy Conference* (Glasgow)
- Grant A D and Dannecker R 2000 A Hybrid PV/Wind Energy Module for Integration in Buildings *Proc. 16th European Photovoltaic Solar Energy Conf.* (Glasgow)
- Hand 1998 Removing Barriers to the Use of Simulation in the Building Design Professions *PhD Thesis* (Glasgow: Department of Mechanical Engineering, University of Strathclyde)
- Larson G W and Shakespeare R 1998 *Rendering with Radiance - The Art and Science of Lighting Visualization* (San Francisco: Morgan Kaufmann)
- McElroy L B and Clarke J A 1999 Embedding Simulation Within Energy Sector Businesses *Proc. Building Simulation '99* (Kyoto)