

The Linear Matching Method applied to the High Temperature Life Integrity of Structures

Part 1: Assessments involving Constant Residual Stress Fields

H. F. Chen^{*}, A. R. S. Ponter^{*} and R. A. Ainsworth[°]

^{*} Department of Engineering, University of Leicester, Leicester, LE1 7RH, UK
[°] Plant Integrity Branch, British Energy Generation Ltd, Barnett Way, Barnwood, Gloucester, GL4 3RS, UK

Abstract: Design and life assessment procedures for high temperatures are based on ‘expert knowledge’ in structural mechanics and materials science, combined with simplified methods of structural analysis. Of these R5 is one of the most widely used life assessment methods internationally with procedures based on reference stress techniques and shakedown calculations using linear elastic solutions. These have been augmented by full finite element analysis and, recently, the development of a new programming method, the Linear Matching Method (LMM), that allows a range of direct solutions that include shakedown methods and simplified analysis in excess of shakedown. In this paper LMM procedures are compared with calculations typical of those employed in R5 for cyclic loading problems when the assumption of a *constant* residual stress field is appropriate including shakedown and limit analyses, creep rupture analysis and the evaluation of accumulated creep deformation. A typical example of a 3D holed plate subjected to a cyclic thermal load and a constant mechanical load is assessed in detail. These comparisons demonstrate the significant advantages of linear matching methods for a typical case. For a range of cyclic problems when the residual stress field *varies* during the cycle, which include the evaluation of plastic strain amplitude, ratchet limit and accumulated creep strains during a high temperature dwell periods, the corresponding LMM and R5 procedures are discussed in an accompanying paper.

Keywords: linear matching; shakedown; creep rupture; rapid cycle solution

Notation

a	radius of the hole
B, Q, n	creep materials data
D, L	diameter of the hole and length of the plate
N	number of load instance
$P_i(x_j, t)$	mechanical loads
P_S	shakedown limit
r	distance to the centre of hole
R, g	functions of creep rupture time and temperature
S_u, S_T	displacement and load boundary surfaces
\bar{t}, t_m	time instance and m th time instance
$t, \Delta t$	time and cycle time

t_f	time to creep rupture
u_i	displacement
V, S	volume and surface of the body
$\theta(x_j, t)$	temperature history
$\theta_0, \bar{\theta}$	temperatures at the edge of the plate and hole
$\theta, \Delta\theta$	temperature distribution and temperature variation
$\mu, \bar{\mu}$	shear modulus and effective shear modulus
λ, λ_{UB}	load parameter and upper bound shakedown limit multiplier
λ_S	exact shakedown limit multiplier
$\bar{\sigma}$	von Mises effective stress
σ_R	reference stress
$\hat{\sigma}_{ij}$	linear elastic stress
$\hat{\sigma}_{ij}^\theta, \hat{\sigma}_{ij}^P$	elastic thermal stress and mechanical stress
$\sigma_{ij}(x_i, t)$	cyclic stress history
$\sigma_c(t_f, \theta), \sigma_y^{LT}$	creep rupture stress and yield stress
σ_P, σ_t	effective tension and maximum effective elastic thermal stress
σ_{t0}	specific maximum effective elastic thermal stress
σ_y, E, ν	yield stress, elastic modulus and Poisson's ratio
$\bar{\rho}_{ij}, \rho_{ij}^r$	constant and changing residual stress field
$\dot{\epsilon}_{ij}, \bar{\epsilon}$	strain rate and von Mises effective strain rate
$\Delta\epsilon_{ij}$	strain increment
$\dot{\epsilon}_s^c$	steady state creep strain rate
$\Delta\epsilon_{ij}^c$	creep strain increment per cycle.

1. Introduction

Both high temperature design and life assessment methods have developed since the 1960's through an accumulation of expert knowledge and procedural devices. They tend to rely upon simplified methods of structural analysis, originally based on limit load and shakedown concepts, augmented by reference stress methods. Calculations rely, primarily, upon linear elastic solutions and constant residual stress fields generated from thermo-elastic fields. Such methods combine the dual needs of simple conservative calculations that make use of standard collections of uniaxial test data without the need for the development of full constitutive descriptions. Of these procedures the high temperature life assessment procedure R5 [1] is currently one of the most widely used methods, internationally, for the high

temperature response of structures and represents the most advanced form of this approach to life assessment.

A simplified flow chart of the R5 assessment procedure for structures subjected to cyclic thermal and mechanical loads is shown in Fig. 1. The procedure involves a sequence of calculations, linear elastic analysis, possible creep rupture analysis, shakedown analysis, rapid cycle creep solutions, fatigue damage assessment, creep relaxation evaluation and the resulting estimation of component lifetime. It is also worth noting that the actual assessment steps depend on the specified problems. For example, if insignificant creep is satisfied due to low temperature, it is not necessary to assess creep rupture. When the structure contains inherent defects, crack initiation and propagation become important.

In Fig. 1 we have subdivided the entire procedure into Parts I and II, with the distinction that Part I involves calculations with a constant residual stress field whereas Part II is concerned with phenomena related to a changing residual stress field. In this paper we discuss problems in Part I: shakedown and limit analyses, creep rupture analysis and the evaluation of cyclically enhanced creep deformation. An accompanying paper [2] considers a range of cyclic loading problems involving changing residual stress field, which includes the evaluation of plastic strain amplitude, ratchet limit and elastic follow-up over a creep dwell.

In recent years the R5 and other assessment procedures have been augmented by full inelastic analysis. With the advent of increasing computer capacity and speed, such methods can become viable as an alternative to current methods but suffer from two inherent disadvantages. The need for a full constitutive description is often not matched by the range of material data available where historical materials data bases are often the only source. In addition a full inelastic analysis for a specific loading history provides little insight into the proximity to load levels where significant changes of behaviour occur. In other words a significant part of the accumulated expert knowledge of structural behaviour becomes unusable. An alternative approach has been the use of so called 'direct methods' for shakedown and related issues. Linear and non-linear programming methods have been applied to the upper and lower bound shakedown theorems since the 1960's but have remained a research tool applied, often very profitably, to a range of research problems. Recently a new class of method has appeared, Linear Matching Method (LMM), that has the advantages of greater flexibility and the ability to be easily integrated into standard finite element codes.

The Linear Matching Method [3, 6-15] involves the matching of the non-linear material behaviour to a linear material and forms the basis for a powerful upper bound programming method that may be applied to a significant class of direct methods. Its origins may be found

in the Elastic Compensation Method [4,5] and related methods that were originally developed as approximate analysis methods for design. The Linear Matching Method has been applied with considerable rigour to cyclic loading problems where the residual stress field remains constant [3, 6-11]. This includes classical limit loads, shakedown limits, creep rupture and a class of high temperature creep problems, rapid cycle problems, where the cycle time is small compared with material time scales. For the steady cyclic behaviour associated with complex histories of load and temperature where the residual stress field changes during a cyclic state, the Linear Matching Method can still be used [12-15]. This includes the plastic strain amplitude and ratchet limit associated with reverse plasticity mechanism, the creep strain accumulation and elastic follow-up during a creep dwell period associated with the creep-reverse plasticity mechanism. A summary of the solution sequence for structural integrity assessment based on the Linear Matching Method is given in Table 1, which concerns a range of cyclic problems corresponding to the R5 procedures of Fig. 1.

In this paper, both the R5 procedures and LMM procedures are presented and compared for the evaluation of cyclic loading problems involving a constant residual stress field. The purpose of this paper is not only to present the Linear Matching Method assessment procedures for the high temperature response of structures, but also to demonstrate that the method has both the advantages of programming methods and the capacity to be implemented easily within commercial finite element codes. For the calculations described here ABAQUS [16] has been used. Following a brief statement of the general problem in section 2, materials data and the specific geometry considered are described in Sections 3-4, respectively. Section 5 presents results of the shakedown analyses, creep rupture and creep deformation calculations. The paper then concludes with a short discussion and conclusions in Section 6 and 7, respectively.

2. Statement of problem

Consider the following problem. A structure is subjected to a cyclic history of varying temperature $\lambda\theta(x_i, t)$ within the volume of the structure and surface loads $\lambda P_i(x_i, t)$ acting over part of the structure's surface S_T . The variation is considered over a typical cycle $0 \leq t \leq \Delta t$. Here λ denotes a load parameter, allowing a whole class of loading histories to be considered. On the remainder of the surface S , denoted S_u , the displacement $u_i = 0$.

Corresponding to these loading histories there exists a linear elastic solution history;

$$\lambda \hat{\sigma}_{ij} = \lambda \hat{\sigma}_{ij}^{\theta} + \lambda \hat{\sigma}_{ij}^P \quad (1)$$

where $\hat{\sigma}_{ij}^{\theta}$ and $\hat{\sigma}_{ij}^P$ are the elastic solutions corresponding to $\theta(x_i, t)$ and $P_i(x_i, t)$, respectively.

For cyclic problems the cyclic stress history, during a typical cycle $0 \leq t \leq \Delta t$, irrespective of material properties is given by

$$\sigma_{ij}(x_i, t) = \lambda \hat{\sigma}_{ij}(x_i, t) + \bar{\rho}_{ij}(x_i) + \rho_{ij}^r(x_i, t) \quad (2)$$

where $\bar{\rho}_{ij}$ denotes a constant residual stress field in equilibrium with zero surface tractions on S_T and corresponds to the residual state of stress at the beginning and end of the cycle. ρ_{ij}^r denotes the changing component of residual stress. In this paper we are concerned with calculations for which it is appropriate to assume $\rho_{ij}^r = 0$.

Both the Linear Matching Method and R5 are concerned with properties of this cyclic solution, based upon a sequence of constitutive assumptions, drawing on the database of materials data, discussed in the next section. Whereas R5 relies significantly on rule-based calculations based on the linear elastic solution, the Linear Matching Method produces direct calculations of various performance indicators as derived from simplified continuum problems.

3. Material data

Materials data requirements are listed in Table 2 for various types of computations involving the constant residual stress field. If the component is subjected to high temperature, the corresponding material data of thermal conductivity, specific heat and density are necessary for transient or steady thermal analysis. Once the temperature field of the component is known, Young's modulus E (single value or table of values for a range of temperature), Poisson's ratio ν and the coefficient of thermal expansion α are needed for the linear elastic analysis.

For inelastic analysis, standard uniaxial data are relied on. For the shakedown and limit analysis, either a single value of yield stress or a table of values of yield stress at a range of temperatures is required. For creep rupture analysis, the time to creep rupture at constant stress and temperature is assumed available. For the evaluation of cyclic accumulation of creep strain, steady state creep data are required.

The particular functional forms and material coefficients adopted are listed in Table 3. This type of simple materials data is that normally required for life assessment and, for comparison purposes, identical data are chosen for both the R5 assessment and the LMM procedure. We

assume that elastic properties and the yield stress are independent of temperature, but include the temperature variation of creep rupture and creep deformation properties.

4. The Sample Problem

In this paper, a 3-D holed plate is assessed in detail as a typical example. The geometry of the structure and its finite element mesh are shown in Fig. 2. The 20-node solid isoparametric elements with reduced integration are adopted. The ratio between the diameter D of the hole and the length L of the plate is 0.2 and the ratio of the depth of the plate to the length L of the plate is 0.05.

The plate is subjected to a temperature difference $\Delta\theta$ between the edge of the hole and the edge of the plate and uniaxial tension σ_p acts along one side. The variation of the temperature with radius r was assumed to be;

$$\theta(r,t) = \theta_0 + (\bar{\theta}(t) - \theta_0) \ln(5a/r) / \ln(5) \quad (3)$$

where a is the radius of the hole and r is the distance to the centre of hole. Equation (3) gives a simple approximation to the temperature field corresponding to $\theta = \bar{\theta}(t)$ around the edge of the hole and $\theta = \theta_0$ at the edge of the plate. The detailed temperature history $\bar{\theta}(t)$ around the edge of the hole is given in Fig.3, where $\bar{\theta}(t)$ varies between θ_0 and $\theta_0 + \Delta\theta$. The temperature at the edge of the plate remains at θ_0 . The maximum von Mises effective thermo elastic stress, which occurs at the edge of the hole is denoted by σ_t . Hence the extremes of the load history are characterised by σ_p and σ_t .

5. High Temperature Life Assessment Method

The essential steps in R5 are summarised in Table 1. The eight stages involve assessments of the significance of various modes of behaviour corresponding to a particular loading history and material data set, with the expectation that a single mode of behaviour will tend to dominate. In the following, the Linear Matching Method approach to each stage is discussed and then applied to the sample problem. The results are then compared with the corresponding result provided by the type of methodology used in R5. The results are shown in the form of interaction diagrams that show contours of a constant condition for varying proportions of the applied mechanical and thermal loading, i.e. σ_p and σ_t , from pure mechanical load to pure thermal loading. This approach helps to illustrate the differences between the two methods. In this paper we discuss Stages 1 to 5 all of which involve

calculations that assume a constant residual stress field $\bar{\rho}_{ij}$ and $\rho_{ij}^r = 0$. Stages 6 to 8 require the evaluation of the variation of ρ_{ij}^r , which will be discussed in detail in an accompanying paper [2].

5.1 Stages 1 and 2- Temperature and Elastic Stress Field

Both R5 and LMM presume the temperature and linearly elastic stress history fields are available for the entire body. LMM relies upon the identification of a finite number of instants during the cycle as representative of the entire history, although for many of the calculations there is no limit to the number considered. For the evaluation of the ratchet limit in excess of shakedown [2], the plastic strain amplitude and the relaxation creep strain during dwell periods, currently LMM is fully developed for the special case of only two such instants. A full implementation for an arbitrary number of instants is under development. Temperature and elastic solution data sets provide the input into all the subsequent LMM where either constant residual stress fields or amplitudes of varying residual stresses are evaluated, i.e. LMM evaluates the adaptations to the linear elastic solutions due to the presence of inelastic strains. R5 also requires the identification of instants when extreme conditions occur and often assumes that only two such instants need be considered.

In this paper, an elastic stress field and the maximum effective value, σ_{t0} , at the edge of the holed plate due to the thermal load were calculated by ABAQUS [16], with $\theta_0 = 200^\circ C$, $\Delta\theta = 400^\circ C$ and a coefficient of thermal expansion of $1.25 \times 10^{-5} \text{ } ^\circ C^{-1}$. It is a coincidence that the obtained σ_{t0} by the above temperature loads is the reverse plasticity limit, i.e. $\sigma_{t0} = 2\sigma_y$. Figs. 4a and 4b give the contours of elastic von Mises effective stresses with pure thermal loads ($\theta_0 = 200^\circ C$, $\Delta\theta = 400^\circ C$) and pure axial tension $\sigma_p = 360 \text{ MPa}$, respectively. A severe stress concentration occurs around the edge of the hole as expected. The above two elastic stress solutions are then used to evaluate the shakedown limit, creep rupture and rapid cycle creep solutions using the Linear Matching Method. These two standard linear elastic stress fields, which we denote by $\hat{\sigma}_{ij}^p$ and $\hat{\sigma}_{ij}^\theta$ form the input data to both the Linear Matching Method and the R5 procedures.

5.2 Stage 3 - Shakedown Analysis

Linear Matching Method

A component is said to shakedown when, on the basis of perfect plasticity, behaviour during the steady state cyclic operation is elastic at every point in the structure even though there may be some yielding during early cycles of load. The LMM was originally developed for shakedown of an elastic perfectly plastic solid [3] and gives particularly stable solutions. The method consist of an iterative process where a sequence of upper bounds to the load parameter λ_{UB} to the exact shakedown limit λ_s are derived from a sequence of linear problems for the residual stress field according to an incompressible linear viscous matching model. The sequence monotonically reduces, typically in 30 iterations, to the least upper bound associated with the finite element mesh. This means that the converged shakedown limit is evaluated to the same level of accuracy as the linear elastic solution.

A single iteration begins with the evaluation of a varying shear modulus μ by matching the stress due to the linear model and the yield condition at the strain rate $\dot{\varepsilon}_{ij}^i$ yielded by the previous iteration. This yields the relationship;

$$\frac{3}{2}\mu\bar{\varepsilon}^i = \sigma_y \quad (4)$$

With μ known, the following incompressible linear relation is proposed at each instant in the cycle for a constant residual stress field $\bar{\rho}_{ij}^f$.

$$\dot{\varepsilon}_{ij}^{f'} = \frac{1}{\mu(t)}(\lambda_{ub}^i \hat{\sigma}_{ij} + \bar{\rho}_{ij}^f)', \quad \dot{\varepsilon}_{kk}^f = 0 \quad (5)$$

The value of $\lambda = \lambda_{UB}^i$ corresponds to the upper bound given by $\dot{\varepsilon}_{ij}^i$. The solution for $\bar{\rho}_{ij}^f$ is then obtained by integrating (5) over the cycle, yielding a linear relationship between the compatible increment of plastic strain over the cycle $\Delta\varepsilon_{ij}^f$ and $\bar{\rho}_{ij}^f$.

$$\Delta\varepsilon_{ij}^{f'} = \frac{1}{\bar{\mu}}(\bar{\rho}_{ij}^{f'} + \sigma_{ij}^{in}), \quad \Delta\varepsilon_{kk}^f = 0 \quad (6)$$

where
$$\sigma_{ij}^{in} = \bar{\mu} \left\{ \int_0^{\Delta t} \frac{1}{\mu(t)} \lambda_{UB}^i \hat{\sigma}_{ij}'(t) dt \right\} \text{ and } \frac{1}{\bar{\mu}} = \int_0^{\Delta t} \frac{1}{\mu(t)} dt. \quad (7)$$

This new solution now gives a new upper bound on the shakedown limit;

$$\lambda_{UB}^f = \frac{\int_V \int_0^{\Delta t} \sigma_y \bar{\varepsilon}(\dot{\varepsilon}_{ij}^f) dt dV}{\int_V \int_0^{\Delta t} (\hat{\sigma}_{ij} \dot{\varepsilon}_{ij}^f) dt dV} \quad (8)$$

where $\bar{\varepsilon} = \sqrt{\frac{2}{3} \dot{\varepsilon}_{ij} \dot{\varepsilon}_{ij}}$ is the effective strain rate.

Generally theory [3, 6-8] then shows that $\lambda_{UB}^f \leq \lambda_{UB}^i$. Repeating the process produces a sequence of upper bounds that converge to the least upper bound. At the converged state the stress history $\lambda_{UB} \hat{\sigma}_{ij} + \bar{\rho}_{ij}$ is at or less than yield at every Gauss point in the finite element mesh.

As the iterative process provides a sequence of residual stress fields it is possible to evaluate a lower bound at each state by scaling the elastic solution so that $\lambda_{LB} \hat{\sigma}_{ij} + \bar{\rho}_{ij}$ everywhere satisfies yield. Such a process converges to λ_{UB} rather more slowly than the upper bound and, as a result, does not provide any further information.

For the solution of practical problems, N instants are identified during the loading histories when extremes of the elastic stress history occur. At each instant a plastic strain increment $\Delta \varepsilon_{ij}^l$ occurs, $l = 1, \dots, N$. The equation set (5) to (7) then become finite sums;

$$\Delta \varepsilon_{ij} = \sum_{l=1}^N \Delta \varepsilon_{ij}^l \quad (9)$$

and equations (6) and (7) become

$$\Delta \varepsilon_{ij}^{\prime f} = \frac{1}{\bar{\mu}} (\bar{\rho}_{ij}^{\prime f} + \sigma_{ij}^{\prime in}) \quad (10)$$

$$\sigma_{ij}^{\prime in} = \bar{\mu} \left\{ \sum_{m=1}^N \frac{1}{\mu_m} \lambda \hat{\sigma}_{ij}^{\prime}(t_m) \right\} \quad (11)$$

where

$$\frac{1}{\bar{\mu}} = \sum_{l=1}^N \frac{1}{\mu_l} \quad \text{and} \quad \frac{3}{2} \mu_l \bar{\varepsilon} (\Delta \varepsilon_{ij}^{li}) = \sigma_y \quad (12)$$

For the sample problem, converged values of the shakedown limit are shown in Fig. 5 as an interaction diagram, composed of the limit for differing ratios of thermal and mechanical loads. The limit divides into two regions and corresponding to AB, a reverse plasticity limit and BC, a ratchet limit. When the applied load is beyond the reverse plasticity limit AB, shakedown does not occur and the permanent strains settle into a closed cycle – a situation also known as “cyclic” or “alternating plasticity”. If the applied load is beyond the ratchet limit BC, the permanent plastic strains go on increasing indefinitely – known as “ratchetting”. The point C corresponds to the limit load for the applied mechanical load. Fig. 6 shows a typical upper bound sequence with convergence occurring in about 30 iterations. In practice,

convergence is assumed to have occurred when the following equation is satisfied for more than five consecutive iterations.

$$\frac{|\lambda_{ub}^{k+1} - \lambda_{ub}^k|}{\lambda_{ub}^k} \leq \delta \quad (13)$$

where δ , equals 10^{-4} in the present paper, is the desired accuracy of the calculation.

Limit analysis is treated by LMM as the special case when the loads are constant. It is possible to evaluate the limit load without first evaluating the linear elastic solution [3]. However, implementation is simplified by considering only the shakedown method, described above, and treating limit analysis as a special case.

R5 Assessment

For shakedown, R5 uses a lower bound method for both the limit load and the shakedown limit. The state of shakedown is brought about by the action of residual stresses left by the early cycles of load. The stress at any point in the shakedown cycle can then be obtained by the addition of the elastically calculated stress $\lambda \hat{\sigma}_{ij}(x_i, t)$ and a residual stress $\bar{\rho}_{ij}(x_i)$ which is constant with respect to time t , so the test for shakedown is given by

$$\bar{\sigma}(\lambda \hat{\sigma}_{ij}(x_i, t) + \bar{\rho}_{ij}(x_i)) \leq \sigma_y \quad (14)$$

where $\bar{\sigma}$ is the von Mises effective stress.

The lower bound theorem of shakedown states that the use of any estimate of residual stress $\bar{\rho}_{ij}(x_i)$ will result in a conservative estimate of the ability of a structure to shakedown. In R5 any estimate of residual stress field is allowed and sometimes temperature fields are imposed to generate such fields. However, often the calculated thermal stress $\bar{\rho}_{ij} = \alpha \hat{\sigma}_{ij}^\theta(\bar{t})$ is adopted as a candidate residual stress field and hence a steady cyclic stress history $\lambda \hat{\sigma}_{ij}^p + \lambda \beta \hat{\sigma}_{ij}^\theta(t) + \alpha \hat{\sigma}_{ij}^\theta(\bar{t})$ is determined, where \bar{t} is an instant during the cycle, usually when the thermo-elastic stress has its maximum value. This is the approach adopted in the R5 analysis presented here. For a given elastic stress history defined by the proportion of thermal stress β , the two constants α and λ are adjusted so that the von Mises yield condition is satisfied everywhere. For our example, the best lower bound possible by this approach is given by a straight line between the reverse plasticity limit for thermal loading, point A, and the elastic limit of mechanical load with thermal load effect, point D as shown in Fig. 5.

A significant difference can be seen between the shakedown limits by LMM and the chosen R5 procedure, primarily because the choice of $\bar{\rho}_{ij} = \alpha \hat{\sigma}_{ij}^{\theta}(\bar{t})$ provides a poor approximation for the limit load. In fact the computed shakedown boundary involves two distinct residual stress fields, corresponding to the ranges AB and BC neither of which are well approximated except at point A when $\bar{\rho}_{ij} = \alpha \hat{\sigma}_{ij}^{\theta}(\bar{t})$ is exact.

5.3 Stage 4 Creep Damage – Time to Creep Rupture

In R5, the evaluation of the creep rupture time is treated as an extended shakedown problem. The stress history is given, again, by the shakedown form $\lambda \hat{\sigma}_{ij} + \bar{\rho}_{ij}$ with the restriction that the stress history must satisfy both a yield condition and a creep rupture condition. In terms of von Mises conditions this corresponds to;

$$\sigma_y(x_i, t_m) = \min \left\{ \begin{array}{l} \sigma_y^{LT} \\ \sigma_c(t_f, \theta(x_i, t_m)) \end{array} \right\} \quad (15)$$

where

$$\sigma_c(t_f, \theta) = \sigma_y^{LT} R\left(\frac{t_f}{t_0}\right) g\left(\frac{\theta}{\theta_0}\right) \quad (16)$$

where σ_y^{LT} is the yield stress when the temperature is low (below the creep range) and σ_c is the stress to cause creep rupture in time t_f at temperature θ . $\sigma_c(t_f, \theta) = \sigma_y^{LT}$ when

$R\left(\frac{t_f}{t_0}\right) g\left(\frac{\theta}{\theta_0}\right) = 1$. t_m is the m th instant during the cycle. In order to simplify the calculation,

for the example of the 3D holed plate in the paper, the form of temperature dependence for

σ_c has been adopted as $g\left(\frac{\theta}{\theta_0}\right) = \frac{\theta_0}{\theta - \theta_0}$, where $\theta_0 = 200^\circ C$. A graph of the temperature

dependent yield stress verses temperature is shown in Fig. 7. $R(t_f)$ is a creep parameter that

depends upon the time to creep rupture t_f , which is understood as a property of the structure

as a whole. It should be noted that the adoption of a simple expression for R in equation (16)

is sufficient to demonstrate the advantage of LMM over the simplified application of the R5

procedure, which is the main purpose of the paper. In engineering practice, direct use of the

time to creep rupture t_f can be made in equation (16). However the acquisition of a detailed

expression for R from the time to creep rupture t_f is not an easy task. In order to simplify the

calculation, a simple expression of $R = C_1 - C_2 \log(t)$ may be used to fit the experimental data, where C_1 and C_2 are materials constants.

This problem may be posed in two alternative ways;

- 1) The rupture life t_f is defined and we wish to evaluate the maximum value of λ for which the yield conditions above are satisfied. This is a conventional shakedown problem where the appropriate yield value, either σ_y or σ_c is chosen at each instant of the stress history.
- 2) The load parameter λ is defined and the lowest creep rupture time is required so that the stress history lies within yield and the creep constraint (15). This is also a shakedown problem but posed in an unconventional manner. This is a more common problem of making an assessment of component life for known loadings. We discuss below how this may be achieved by the linear matching method.

Linear Matching Method

For problem (1) above, the shakedown method described in Section 5.2 is directly applicable. For problem (2) an adaptation is necessary. Initially an arbitrary value of t_f , or equivalently R , is chosen with the expectation that the corresponding value of λ_s is less than the prescribed value. The conventional shakedown process is then applied until the current upper bound equals the prescribed value of λ . The following iteration reduces λ by $-\Delta\lambda$. Using the equation (14) of Ref. [9], λ is raised by $\Delta\lambda$ and R by ΔR so that the upper bound equality remains valid for the current estimate of the deformation field. This process is repeated with the knowledge that, from general theory, $\Delta\lambda$ will be positive at each iteration. Hence R monotonically increases and the process converges to the value of R and hence t_f corresponding to shakedown for the prescribed value of λ . The detailed procedures for creep rupture are presented in [9].

The yield stress of the material σ_y^{LT} is 360 MPa. In Fig. 8 contours of constant creep parameter R are shown. Hence the corresponding contours of constant t_f can be obtained using the relationship between R and t_f . In this paper, the creep parameter R is approximately determined by $R = 3.356 - 0.315 \log(t_f)$, where t_f is the time in hours.

For the two load points A and B in Fig. 8, the process of convergence for prescribed load, method 2, is shown in Fig. 9 in terms of R . During the first few iterations R remains constant

and this corresponds to the sequence when λ reduces. Subsequently λ remains constant and R monotonically increases to its converged value.

In order to show the effects of the creep rupture stress $\sigma_c(t_f, \theta)$ on the revised yield stress σ_y of the structure, Fig. 10 presents the revised yield stress field σ_y of the 3D holed plate at load point A. The revised yield stress field σ_y at load point B are given in Fig. 11. It can be seen that for both load points A and B, in the part of the body with lower temperature the revised yield stress σ_y equals the original yield stress σ_y^{LT} whereas in those parts of the body with higher temperatures the revised yield stress σ_y reduces due to the lower magnitude of the creep rupture stress $\sigma_c(t_f, \theta)$. Although both load point A and B have the same creep parameter $R=0.5$, the component at load point B has the bigger region of lower revised yield stress due to the higher temperature magnitude.

R5 Assessment

As before, R5 uses equation (14) to test the shakedown state with a predefined maximum creep rupture time. The effects of creep rupture are considered by adopting a revised yield stress as in equation (15).

In the specific application of R5, as an approximation to the shakedown state, a calculated thermal stress $\alpha \hat{\sigma}_{ij}^{\theta}(\bar{t})$ is again adopted as a candidate residual stress field and hence a steady cyclic stress history $\lambda \hat{\sigma}_{ij}^p + \lambda \beta \hat{\sigma}_{ij}^{\theta}(\bar{t}) + \alpha \hat{\sigma}_{ij}^{\theta}(\bar{t})$ is determined, where the constants α , β and λ are adjusted so that the von Mises yield condition is satisfied everywhere.

The best lower bound elastic shakedown limit interaction curves possible by this approach are given in Fig. 8 for creep parameters $R=0.1, 0.5, 1.0, 1.5$ and 2.0 , respectively. It can be seen that when the applied thermal stress is less than 5% of σ_{t0} (the thermal stress causing a stress range of $2\sigma_y$), the elastic shakedown limit curve for $R=0.1$ is identical with the R5 elastic shakedown limit curve in Fig. 5, as the creep rupture stress of equation (15) has no effect due to the low temperature. Similarly, when the applied thermal stress is less than 25% of σ_{t0} for $R=0.5$, or 50% of σ_{t0} for $R=1.0$, or 75% of σ_{t0} for $R=1.5$, the corresponding elastic shakedown limit curves including creep are identical with the R5 elastic shakedown limit curve AD in Fig. 5. For $R=2.0$, the whole elastic shakedown limit curve including creep is totally identical with the R5 elastic shakedown limit curve AD in Fig. 5, as the creep rupture stress of equation (15) has no effect at all. For $R=0.1, 0.5, 1.0$ and 1.5 , when the

applied thermal stress is greater than these corresponding critical values of thermal stresses, the elastic shakedown limit curves including creep drop dramatically compared with the R5 elastic shakedown limit curve AD in Fig. 5, as the contribution of the creep rupture stress on the final revised yield stress is significant due to the high temperature.

A significant difference can be seen between the shakedown limits including creep rupture by LMM and the application of the R5 procedures. It is demonstrated that for the assessment of creep rupture, this form of application of the R5 procedure is over-conservative and LMM provides much better solutions, as again a large shakedown load area (Fig. 8) is excluded by the simplified R5 solutions.

5.4 Stage 5 - Creep Deformation

Creep deformation enters the assessment in two ways. The structure suffers overall growth of creep strain per cycle due to dwell periods when the maximum temperature enters the creep regime, producing a maximum net growth of creep strain $\Delta\varepsilon_c$. Such strains are significant if an entire cross section of the structure remains within the creep regime for significant periods of time. For many problems high temperatures occur only within a restricted region surrounded by material that remains outside the creep regime. In such circumstances the effect of creep is to allow stress relaxation within this high temperature region but the overall growth of strain $\Delta\varepsilon_c$ may be small. These localised creep relaxation strains contribute to fatigue damage and are discussed in stage 8 [2]. Here we discuss the evaluation of $\Delta\varepsilon_c$.

Both the Linear Matching Method and R5 call upon the same bounding theory, the ‘rapid cycle solution’, and the following brief summary should be sufficient to understand the basis of the methods described below. A full description is given in [3, 11].

The methods depend upon the following argument. The growth of strain per cycle depends upon the sequence of load changes during the cycle and also the total cycle time Δt . It is useful to consider a set of possible cyclic loading histories, all of which have the same sequence of load and temperature changes but with differing cycle times Δt . If Δt is sufficiently long for the growth of creep strains during the cycle to be everywhere similar in magnitude to the elastic strains, the stresses would tend to relax to a sequence of steady states. On the other hand if Δt is so small that there is insufficient time for stress relaxation to take place, then the stress history will approximate to the same history as for shakedown. In reality such a situation is never achieved except, perhaps, for vibrational loading, but we can ask the question what is the relationship between the growth of strain for a realistic cycle time and

these two extreme cases. We find that the overall creep strain is bounded by these two extremes where the upper bound is given by the ‘rapid cycle’ solution, the limiting case for small Δt . A simple statement of this solution for fixed λ is as follows. The stress history is given by a constant residual stress field, $\sigma_{ij} = \lambda \hat{\sigma}_{ij} + \bar{\rho}_{ij}$. Substituting this stress history into the assumed creep constitutive relationship and integrating over the cycle produces a distribution of strain increment per cycle $\Delta \varepsilon_{ij}^c$. Then the ‘rapid cycle’ solution is given by that residual stress field $\bar{\rho}_{ij}$ for which $\Delta \varepsilon_{ij}^c$ is compatible with a displacement field Δu_i^c .

The solution will, of course, depend upon the constitutive relationship. The material data often only provides steady state creep information and this may be used as the basis for various choices of relationship. A form of calculation is required that tends to overestimate creep strains and this is provided by the Bailey-Orowan [3, 11] relationship where the creep strain at each point in the structure is given by the largest von Mises stress allowing for changes in temperature. This calculation corresponds to a degree of recovery during creep dwell periods that may well be significantly greater than actually occurs, but allows a reasonably simple conservative calculation that requires only steady state creep data. In this paper, in order to evaluate the rapid cycle creep solutions, i.e. the overall creep deformation, the steady state creep data are adopted as

$$\dot{\varepsilon}_s^c = B. \exp \left[\frac{(-Q)}{(\theta + 273)} \right] \bar{\sigma}^n \quad (17)$$

where θ is the temperature ($^{\circ}C$) and $\bar{\sigma}$ is the von Mises stress (MPa). The creep material constants in equation (17) are given in Table 3.

R5 Assessment

R5 evaluates a reference stress σ_R from knowledge of the shakedown limits so that the stress history of equation (2) satisfies $\bar{\sigma}(\sigma_{ij}) \leq \sigma_R$ everywhere. Combining the shakedown reference stress and equation (17), a contour of constant creep strain rate $\Delta \varepsilon^c / \Delta t$ can be obtained. In Fig. 12 we show both contours of constant reference stress and reference creep strain rates using the simplified residual stress in the R5 procedures to calculate the shakedown limit. This could have used a similar procedure to that in Section 5.3 to optimise the constant multiplying the chosen thermal stress as a residual stress. However, this would require another calculation and instead it is simpler to use the shakedown limit already calculated. Then, the magnitude of the shakedown reference stress σ_R totally depends on the

calculated shakedown limit P_S , i.e. $\sigma_R = \frac{P}{P_S} \sigma_Y$. In this specific example, the effect of temperature on the reference creep strain rate is significant due to the adopted creep model of equation (17).

Linear Matching Method

There are two methods of using LMM solutions for comparisons with the results in Fig. 12. The first is the same as in previous stages, the shakedown limit given by LMM replaces the R5 lower bound to define the reference stress. For a strain rate of 1.5067×10^{-14} the resulting contours of constant effective strain rate (SD-LMM) are shown in Fig. 13 and, as before, there is about a factor of two between the R5 and LMM predictions. The two methods give coincident predictions for pure thermal loading.

The second approach involves using the full rapid cycle solution directly. In such solutions, at positions of maximum variation of the elastic stress, reverse creep occurs where the total accumulated creep is constrained by compatibility with the accumulation of creep strain elsewhere. In common with the creep rupture calculation, two possible calculation strategies are possible where either λ is known and we seek the maximum accumulated creep strain per cycle $\Delta \varepsilon^c / \Delta t$ or, alternatively, we require the value of λ that corresponds to a maximum allowable $\Delta \varepsilon^c / \Delta t$. Both solution methods are possible as adaptations of the standard shakedown method described above. Full details are given by Ponter and Engelhardt [3]. If we then place a limit on the maximum accumulated creep strain, this places a more conservative restriction on load than the reference stress method, which, places a restriction on an *average* creep strain rate. For a strain rate of 1.5067×10^{-14} the resulting contour of constant maximum strain rate rapid cycle solution (RCS) is shown in Fig. 13. Notice that this gives a more conservative result than the reference stress curve based on the LMM shakedown values. Hence a more sensible comparison is provided by the contour for a maximum strain rate of $\Delta \varepsilon^c / \Delta t = 8.2494 \times 10^{-14}$ which corresponds to the same mechanical load as an average (reference stress) strain rate value of 1.5067×10^{-14} . Both contours coincide for zero thermal stress. This shows that the full rapid cycle solution, interpreted in this way, gives a significantly less conservative range of allowable load and temperature than solutions based on the R5 reference stress method. This is particularly noticeable for low mechanical load where the rapid cycle solution allows significantly higher maximum

temperatures. This solution demonstrates that LMM has the potential for providing reasonable but much less conservative methodologies than current common application of the R5 methods.

6. Discussion

By the application of both LMM and typical applications of R5 on the 3D holed plate, this paper demonstrates that LMM presents significantly less conservative solutions than these applications of the R5 procedure for the evaluation of shakedown limit, creep rupture and rapid cycle creep solution. As an intermediate approach between simplified analysis based on linear elastic solutions and complex full inelastic step-by-step analysis, the LMM provides the least upper bound shakedown limit associated with the finite element mesh. When the adopted mesh scheme is sufficiently fine, the precision of the calculated shakedown limit can be guaranteed. The associated constant residual stress can be evaluated directly. In applying the R5 procedures, in order to evaluate the shakedown limit, a combination of thermal stresses was adopted to simulate approximately the constant residual stress associated with the shakedown mechanism. Hence, these means of applying R5 only produce a lower bound shakedown limit of variable accuracy, depending upon the details of the load history. The LMM may, therefore, be considered as an optimum means of evaluating the shakedown limit required by R5.

In the R5 procedures, a reference stress technique was adopted to evaluate the creep rupture and overall creep deformation based upon knowledge of shakedown limits. Due to the rather conservative estimates of the shakedown limits, R5 inevitably produced an over-conservative creep rupture solution and rapid cycle creep solutions. The LMM estimates of shakedown enable this over-conservatism to be removed.

The problem of a 3D holed plate examined in the paper demonstrates the potential flexibility of the Linear Matching Method. Traditionally, shakedown analysis has been seen as a method of defining a load parameter for a prescribed distribution of material properties and load history. It is clear from this paper that the shakedown problem may be posed in other ways, such as for creep rupture solution and rapid cycle creep solution; in this particular problem the quantity optimised concerns a material property which enters the problem in the entire volume and during the part or whole load cycle. It is clearly possible, using the type of technique in this paper, to pose a variety of optimisation problems depending upon the needs of the problem.

We have adopted exactly the same methodology as R5 but replaced the approximate method of computing the residual stress fields from the thermoelastic field by computing, within the approximations of finite elements, the exact residual stress field that gives the widest range of loads. Hence, if other methods of finding approximate residual stress fields are used they will not give as good a result as LMM.

The particular choice of the thermo-elastic solution as the residual stress field gives the best result for pure thermal loading where results coincide but worst results for pure mechanical load. LMM indicated that within the entire range of loading two differing residual stress fields are optimal corresponding to the two regions of the shakedown limit AB and BC in Fig. 5. The difference between the R5 limits and the LMM limits are very significant, generally of the order of a factor of 2 on load. This is reflected in all the calculations where the differences are of a similar order of magnitude.

For the evaluation of allowable loads for accumulated creep deformation we make two comparisons. In common with the previous stages we compare the predictions of reference stress predictions using the typical application of the R5 shakedown method and LMM. Again the comparison is similar as shown for the other stages. However for the LMM it is equally simple to use the full rapid cycle solution. For these solutions we may evaluate the allowable loads corresponding to a maximum accumulated creep rate, compared with the average value of the reference stress methods. We find that the full rapid cycle solution gives significantly less conservative answers. This is particularly true for low mechanical load where the allowable maximum temperature is increased by a large margin. This indicates that the greater flexibility of LMM allows calculation methods that are generally in agreement with the R5 philosophy but may be considerably less conservative.

7. Conclusions

This paper presents LM methods typically used with the R5 integrity assessment procedure for the high temperature response of a structure where the residual stress field remains *constant*. This includes shakedown and limit analyses, creep rupture analysis and the evaluation of rapid cycle creep deformation.

Using a 3-D holed plate as a typical numerical example, the obtained shakedown limits, creep rupture solution and rapid cycle creep solution by LMM are compared with the corresponding typical R5 solutions. The LMM produces much less conservative solutions than typical applications of R5 for identical assumptions in terms of both material behaviour and structural calculation. The LMM calculations are capable of providing the optimal

solution to each problem and have the capacity to exploit the current R5 methodology to its maximum extent without the need to change the range of material data currently required. Indeed, no other method of generating residual stress fields is capable of giving better results. The LMM produces an accurate estimate of the shakedown limit whereas generally this is only crudely estimated in engineering applications. If there is any need to make R5 less conservative then this would require a change in R5 methodology.

8. Acknowledgements

The authors gratefully acknowledge the support of the Engineering and Physical Sciences Research Council of the United Kingdom, British Energy Generation Ltd and the University of the Leicester during the course of this work. The authors also thank David Tipping of British Energy for provision of materials data and other help.

9. References

1. Ainsworth R.A. (editor), R5: Assessment Procedure for the High Temperature Response of Structures, Issue 3, British Energy Generation Ltd, 2003
2. Chen H. F., Ponter A.R.S. and Ainsworth R. A., The Linear Matching Method on the Integrity Assessment for the High Temperature Response of Structures Part 2: Assessments involving Changing Residual Stress Fields, *International Journal of Pressure Vessels and Piping*, 2005
3. Engelhardt M., Computational modelling of Shakedown. PhD thesis, University of Leicester, 1999
4. Seshadri R., The effect of multiaxiality and follow-up on creep damage, *ASME J. of Pressure Vessel Tech* 112, 378-385, 1990
5. Boyle J.T., Hamilton R., Shi J., Mackenzie D., Simple method of calculating lower-bound limit loads for axisymmetric thin shells, *ASME J. of Pressure Vessel Tech* 119, 236-242, 1997
6. Chen H. F. & Ponter A.R.S., Shakedown and Limit Analyses for 3-D Structures Using the Linear Matching Method, *International Journal of Pressure Vessels and Piping*, Vol. 78(6), pp. 443-451, 2001
7. Ponter A. R. S., Fuschi P. and Engelhardt M. (2000) Limit analysis for a general class of yield conditions. *European Journal of Mechanics, A/Solids*. 19:401-421.

8. Ponter A.R.S., Engelhardt M., 2000. Shakedown Limits for a General Yield Condition. *European Journal of Mechanics, A/Solids* 19, 423-445.
9. Chen H. F. & Ponter A.R.S., Linear matching method for creep rupture assessment, *International Journal of Pressure Vessels and Piping*, 80, 213-220, 2003
10. Ponter A.R.S., Chen H. F., Boulbibane M. and Habibullah M., The Linear Matching Method for the evaluation of limit loads, shakedown limits and related problems, Fifth World Congress on Computational Mechanics, July 7-12, 2002, Vienna, Austria.
11. Ponter A.R.S., Cocks A.C.F., 1994. Computation of shakedown limits for structural components (Brussels Diagram)-Part 2-The creep range. Nuclear Science and Technology, European Commission, Report No. EUR 15682EN, Luxembourg.
12. Ponter A.R.S. & Chen H. F., A minimum theorem for cyclic load in excess of shakedown, with application to the evaluation of a ratchet limit, *European Journal of Mechanics, A/Solids*, 20 (4), 539-553, 2001
13. Chen H. F. & Ponter A.R.S., A Method for the Evaluation of a Ratchet Limit and the Amplitude of Plastic Strain for Bodies Subjected to Cyclic Loading, *European Journal of Mechanics, A/Solids*, 20 (4), 555-571, 2001
14. Ponter A.R.S., Chen H. F. and Habibullah M., Computation of Ratchet Limits for Structures subjected to Cyclic Loading and Temperature, In: *Computational Developments and Applications*, PVP-Vol 441, 143-152, 2002
15. Chen H. F. & Ponter A.R.S., Methods for the Evaluation of Creep Relaxation and the Amplitude of Reverse Plastic Strain for Bodies Subjected to Cyclic Loading, *ASME Pressure Vessels and Piping Division (Publication) PVP*, v 459, 155-164, 2003
16. ABAQUS, User's Manual, Version 6.2, 2001

Caption

Table 1. Summary of Solution Sequence based on the Linear Matching Method (LMM)

Table 2. The materials data requirement for the computations involving constant residual stress field (Part I)

Table 3. The particular functional forms and material coefficients adopted in the paper

Fig. 1 The flow chart of the R5 assessment procedure for structures with high temperature response

Fig. 2 The geometry of the holed plate subjected to axial loading and fluctuating radial temperature distribution and its finite element mesh

Fig. 3 The temperature history around the edge of the hole with two distinct extremes

Fig. 4 The contour of elastic Von Mises effective stress with (a) pure thermal loads ($\theta_0 = 200^\circ C$, $\Delta\theta = 400^\circ C$); (b) pure axial tension $\sigma_p = 360MPa$

Fig. 5 The elastic and shakedown limit for the holed plate with mechanical and thermal loading

Fig. 6 The typical convergence condition of iterative processes for shakedown analysis

Fig. 7 Graph of temperature dependent yield stress versus temperature

Fig. 8 The shakedown limits for the 3D holed plate for five different creep parameters (R=0.1, 0.5, 1.0, 1.5 and 2.0)

Fig. 9 The convergence conditions for the solution of the optimisation of the creep parameter R for shakedown to occur

Fig. 10 The revised yield stress field of 3D holed plate at load point A

Fig. 11 The revised yield stress field of 3D holed plate at load point B

Fig. 12 Contours of constant reference stress and reference creep strain rates using the R5 procedures.

Fig. 13 The comparison of creep deformations by LMM and R5 Method

Table 1 Summary of Solution Sequence based on the Linear Matching Method (LMM)

Stage	Variable	Calculation Method	Subsidiary calculation/result	Comments	
Part I	1	Temperature $T(x,t)$	Transient temperature history		Same as R5
	2	Elastic stresses $\hat{\sigma}(x,t)$	Transient elastic stress history		Same as R5
	3	Shakedown limit	Elastic shakedown		LMM
	4	Creep damage – time to creep rupture	Extended shakedown solution	Evaluate t_R	LMM
	5	Creep Deformation $\Delta\epsilon^c$	Rapid cycle creep solution, Bailey-Orowan model, constant $\bar{\rho}$	Identify reverse plasticity region for Stage 7	LMM estimate ignoring relaxation
Part II	6	Plastic strain range $\Delta\epsilon^p$	Reverse plasticity solution	Fatigue cycles to failure N_0 from data	LMM
	7	Plastic ratchet limit	Shakedown solution assuming cyclic hardening	Factor of safety on mechanical load λ	LMM with σ_y defined by stage 5.
	8	Creep damage – Elastic follow-up factor	Monotonic creep computation, starting from rapid cycle solution	Creep endurance limit D_c from data, hence creep-fatigue cycles to failure N_0^*	Uses standard ABAQUS routine
Creep-reverse plasticity solution method			LMM		

Table 2. The materials data requirement for the computations involving constant residual stress field (Part I)

Stage	Computation type	The necessary materials data
1	Transient/steady thermal analysis	Thermal conductivity, specific heat, density
2	Linear elastic analysis	Young's modulus E (single value or table of values for a range of temperature), Poisson's ratio ν , coefficient of thermal expansion α
3	Elastic shakedown & limit analysis	Yield stress σ_y (single value or table of values at a range of temperatures)
4	Creep rupture	Yield stress, the time to creep rupture at constant stress and temperature
5	Creep rapid cycle solution	Yield stress, the steady state creep data

Table 3 The particular functional forms and material coefficients adopted in the paper

Stage 2 and 3	Young's modulus E	Poisson's ratio ν	coefficient of thermal expansion α	Yield stress σ_y
	208GPa	0.3	$1.25 \times 10^{-5} / ^\circ C$	360MPa
Stage 4	$\sigma_c(t_f, \theta) = \sigma_y^{LT} R \left(\frac{t_f}{t_0} \right) g \left(\frac{\theta}{\theta_0} \right)$			
	$\sigma_y^{LT} = \sigma_y$	$R = 3.356 - 0.315 \log(t_f)$	$g \left(\frac{\theta}{\theta_0} \right) = \frac{\theta_0}{\theta - \theta_0}, \theta_0 = 200^\circ C$	
Stage 5	$\dot{\epsilon}_s^c = B \cdot \exp \left[\frac{(-Q)}{(\theta + 273)} \right] \cdot \bar{\sigma}^n \text{ (h}^{-1}\text{)}$			
	Ln {B}	Q (K)		n
	-19.607755	1.97×10^4		5

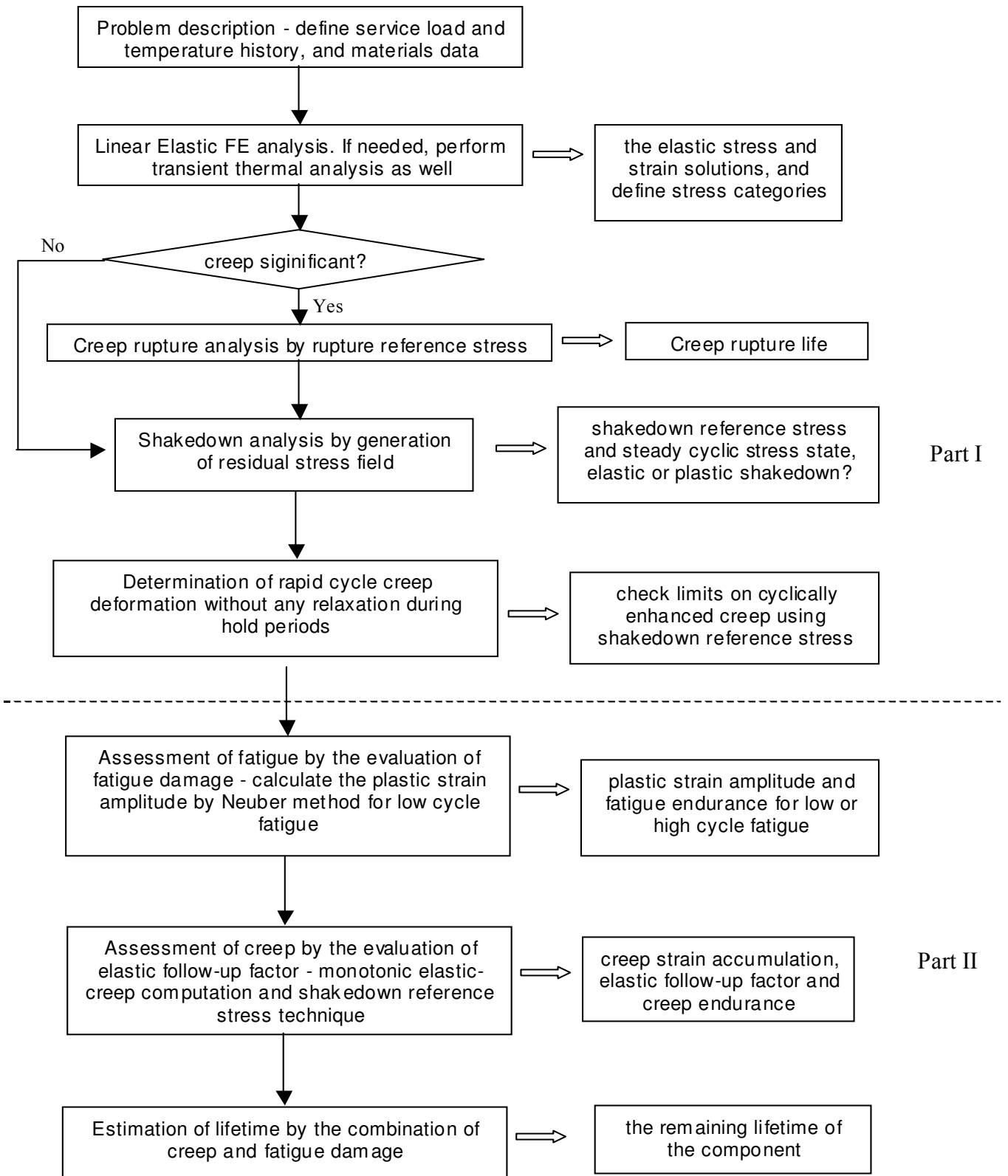

Fig.1 The flow chart of the R5 assessment procedure for structures with high temperature response

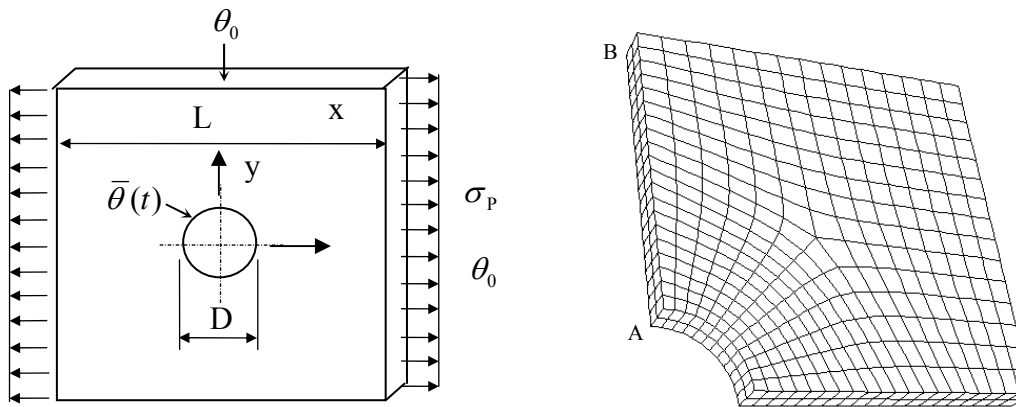

Fig 2 The geometry of the holed plate subjected to axial loading and fluctuating radial temperature distribution and its finite element mesh

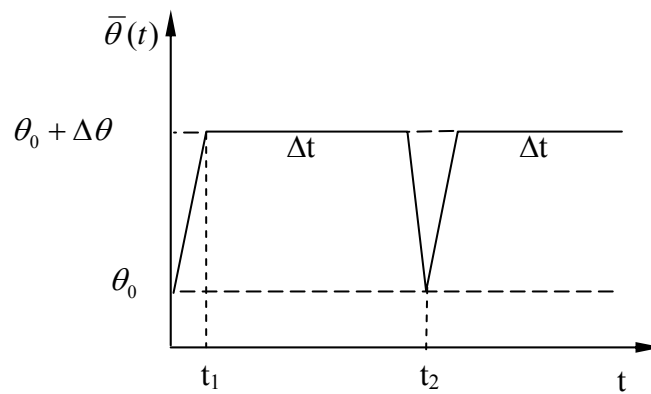
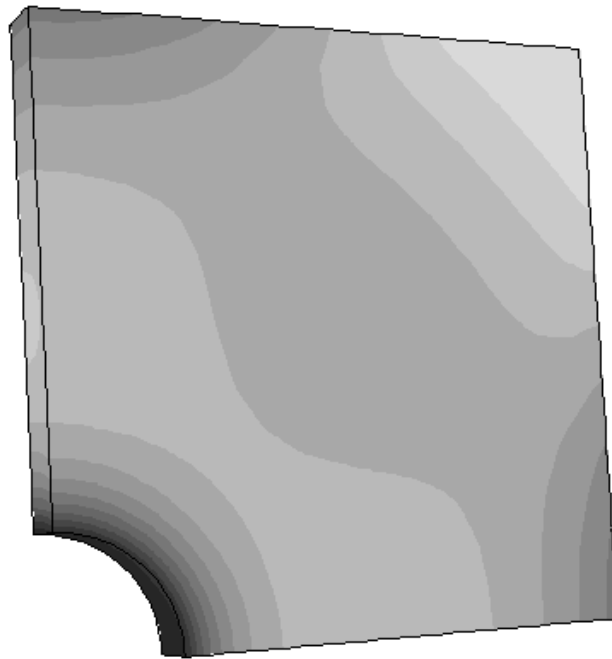
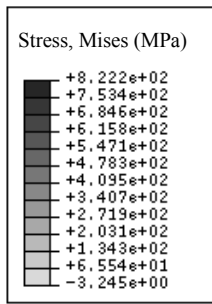
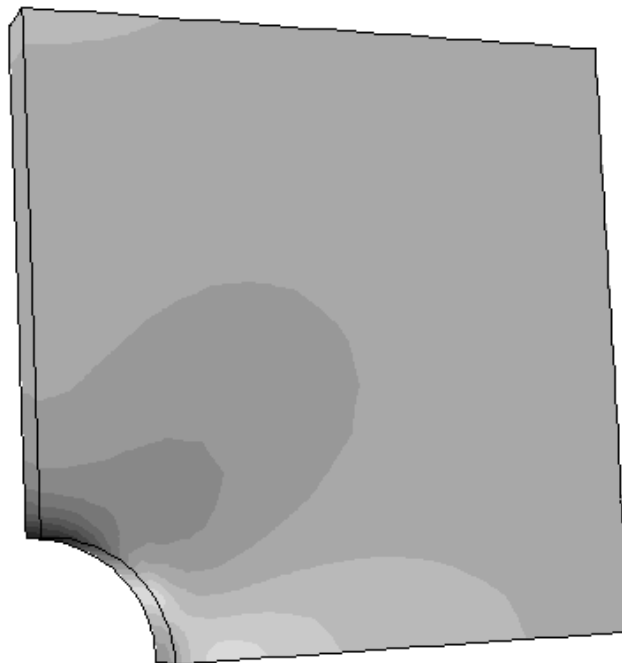
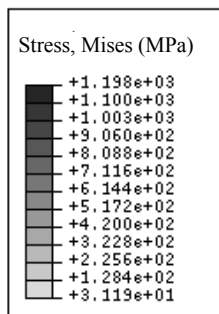

Fig. 3 The temperature history around the edge of the hole with two distinct extremes



(a)



(b)

Fig. 4 The contour of elastic Von Mises effective stress with (a) pure thermal loads ($\theta_0 = 200^\circ C$, $\Delta\theta = 400^\circ C$); (b) pure axial tension $\sigma_p = 360MPa$

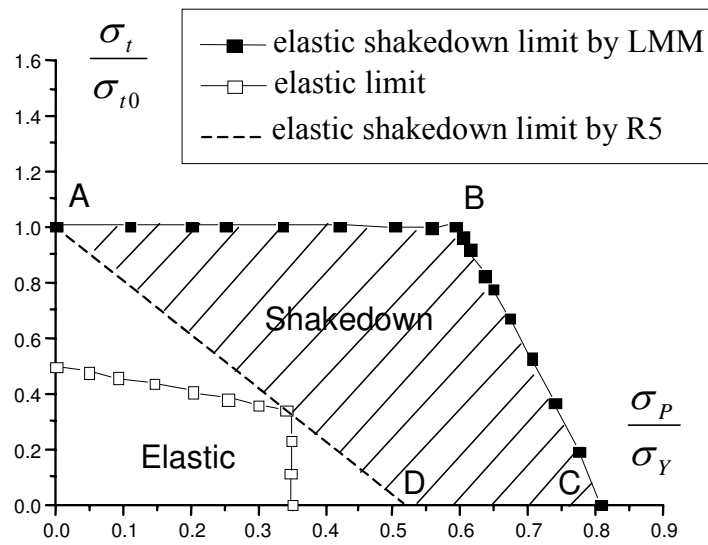

Fig. 5 The elastic and shakedown limit for the holed plate with mechanical and thermal loading

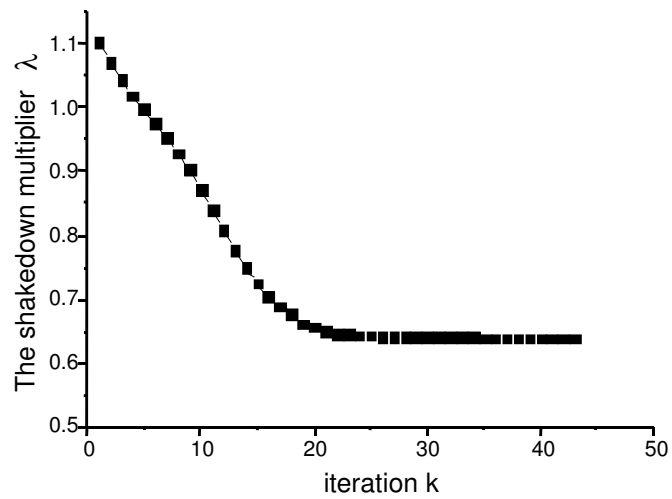

Fig. 6 The typical convergence condition of iterative processes for shakedown analysis

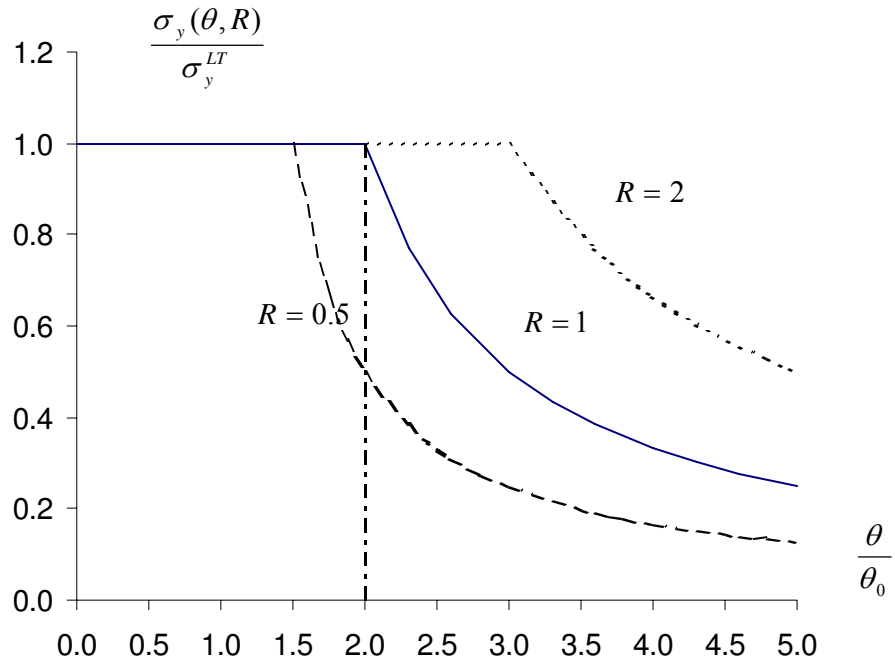

Fig. 7 Graph of temperature dependent yield stress versus temperature

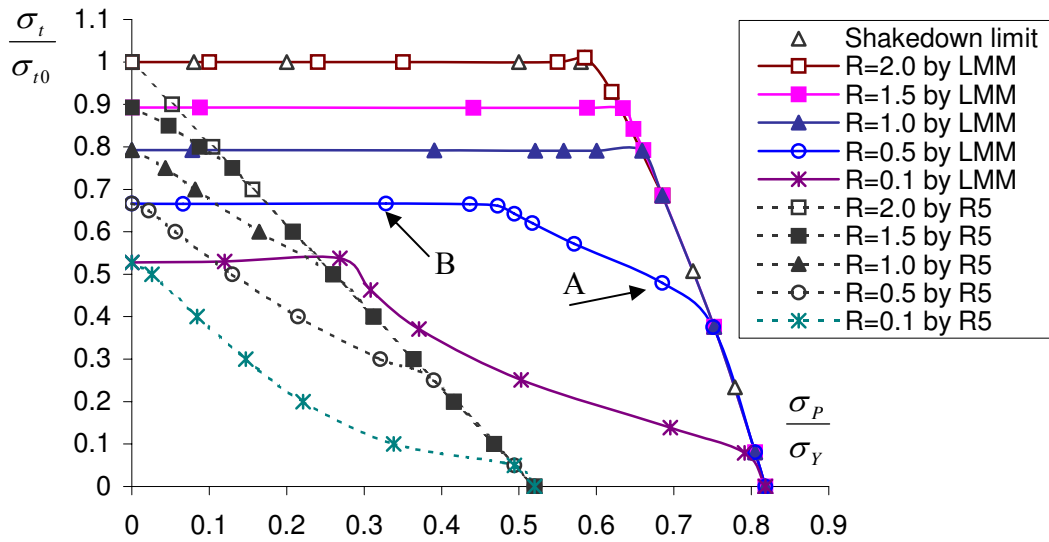

Fig. 8 The shakedown limits for the 3D holed plate for five different creep parameters ($R=0.1, 0.5, 1.0, 1.5$ and 2.0)

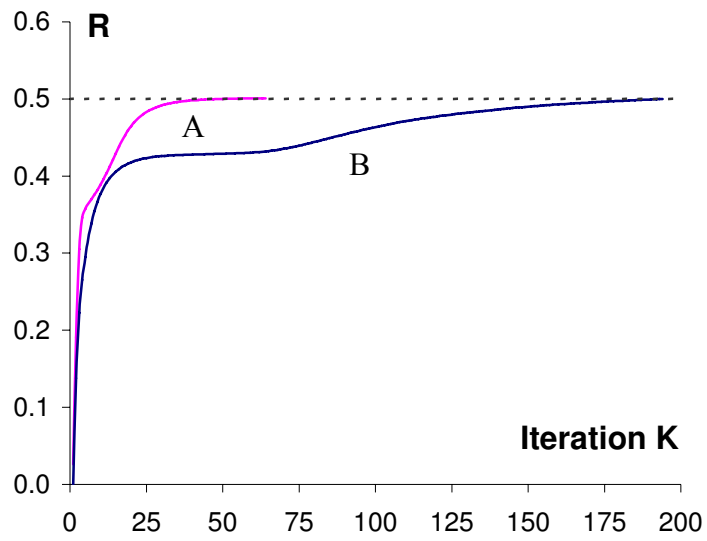

Fig. 9 The convergence conditions for the solution of the optimisation of the creep parameter R for shakedown to occur

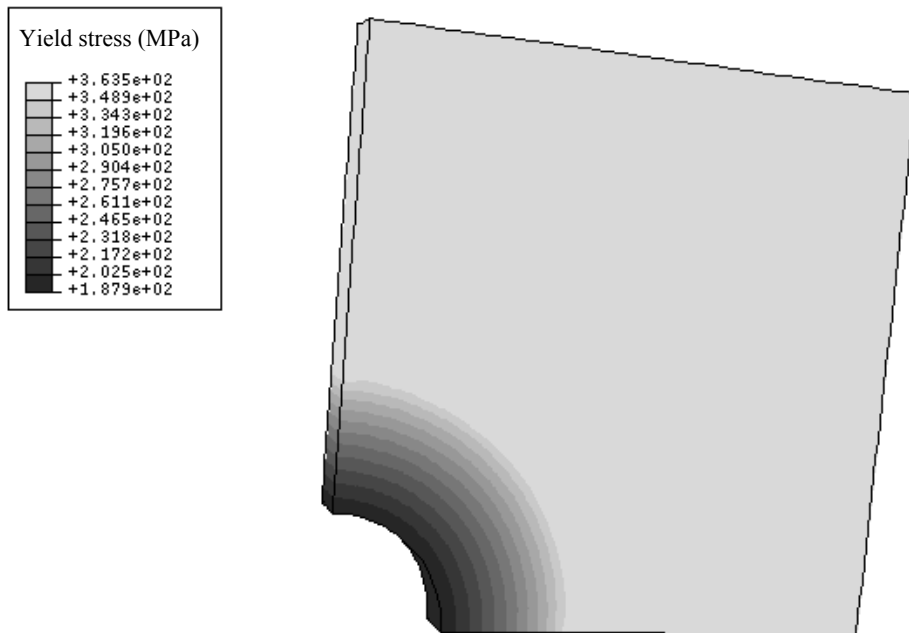

Fig.10 The revised yield stress field of 3D holed plate at load point A

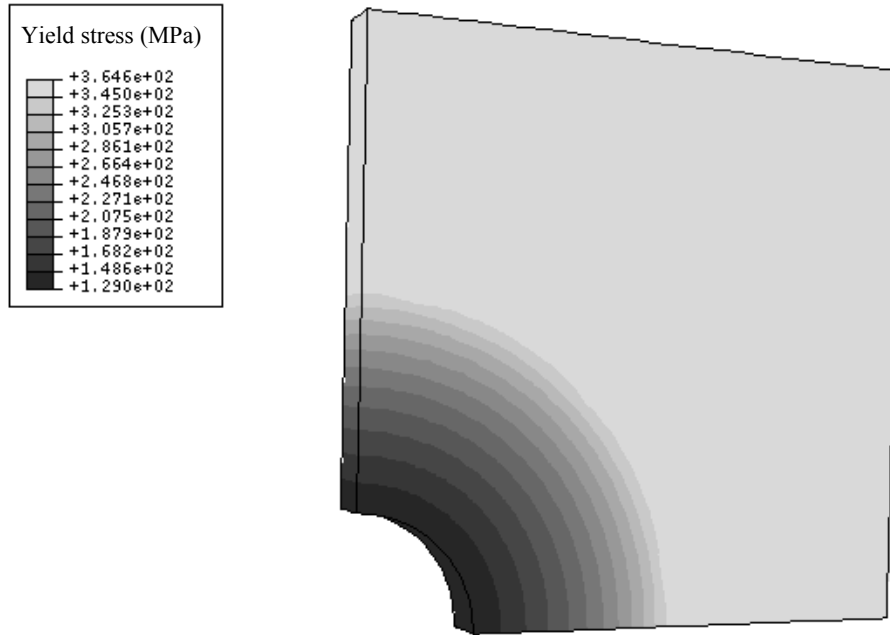

Fig. 11 The revised yield stress field of 3D holed plate at load point B

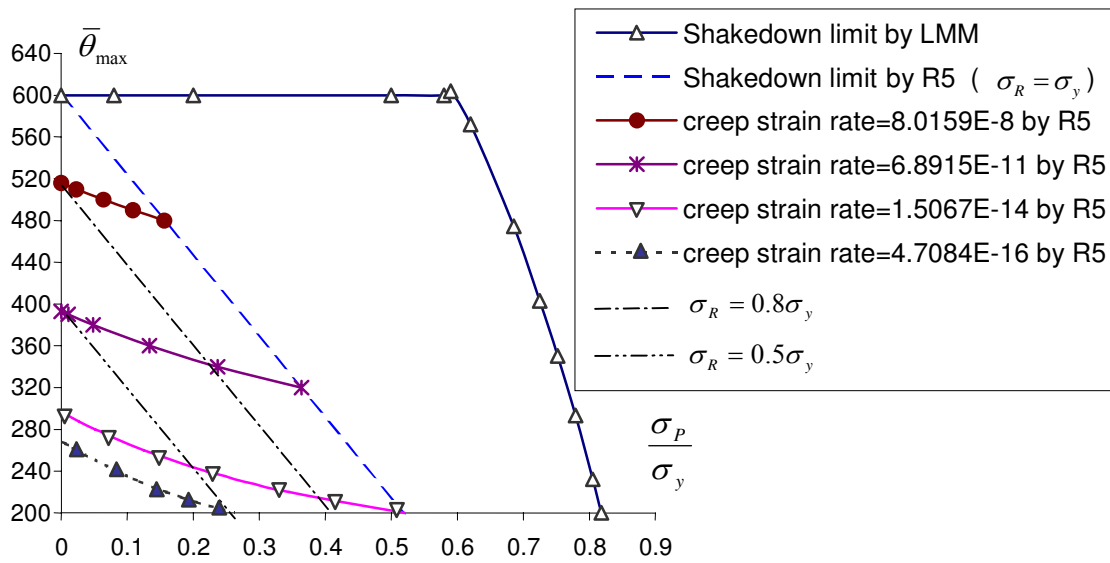

Fig. 12 Contours of constant reference stress and reference creep strain rates using the R5 procedures.

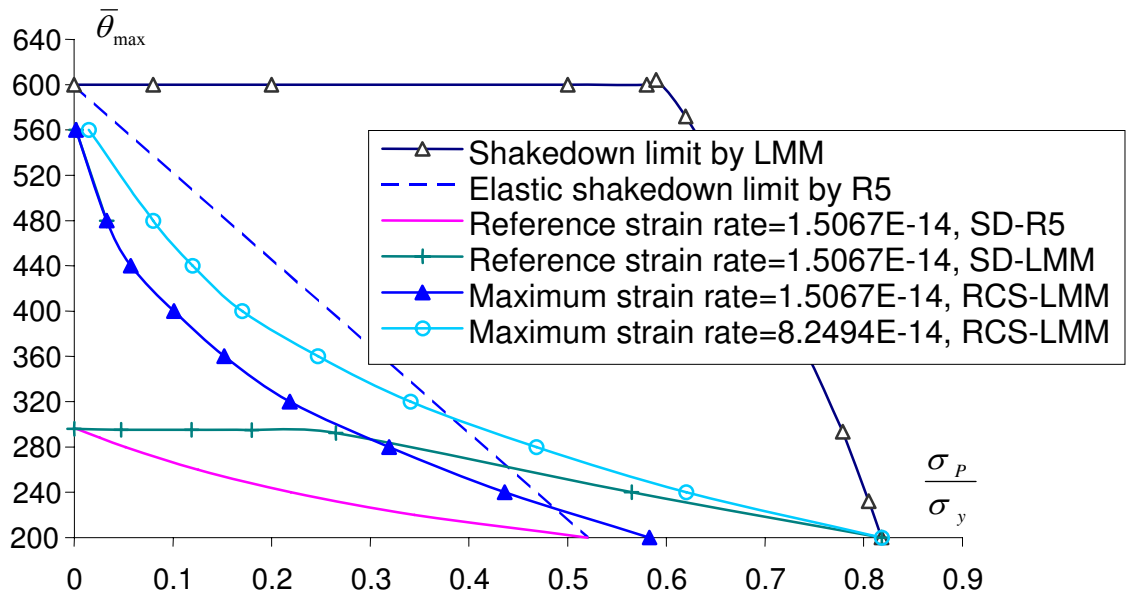

Fig. 13 The comparison of creep deformations by LMM and R5 Method