

# Microcontroller Based Digital Front-End for Near Infrared Spectroscopy

Mario E. Giardini<sup>\*a</sup>, Mario Corti<sup>a,b</sup>, Giovanni G. Guizzetti<sup>a,c</sup>, Paolo Lago<sup>a,d</sup>, Andrea Gelmetti<sup>a,d</sup>,  
Giovanni Danese<sup>a,c</sup>

<sup>a</sup>INFM, via Bassi 6, I-27100 Pavia, Italy

<sup>b</sup>Univ. Milano, Dip. Chimica e Biochimica Medica, Milano, Italy

<sup>c</sup>Univ. Pavia, Dip. Informatica e Sistemistica, Pavia, Italy

<sup>d</sup>Pol. S. Matteo, Ing. Clinica, Pavia, Italy

## ABSTRACT

Near Infrared Spectroscopy (NIRS) can be employed to noninvasively and continuously measure in-vivo local changes in haemodynamics and oxygenation of human tissues. Monitoring of these parameters is particularly useful both for basic research and during surgery, when a continuous and real-time measurement can help to avoid permanent damage to the tissues.

We present a modular acquisition system in which each subsystem, from the case to the single acquisition front-end is designed to meet all the requirements of a research-grade instrument, dedicated to intraoperative measurements.

Part of the modules of the acquisition system has been dedicated to multipoint NIRS. A module prototype has been developed, which is able to control four LED sources and two detectors. On each front-end a RISC microcontroller performs source and detector multiplexing with a digital correlation technique. A number of such modules can be independently addressed through a bus by a PC-based workstation (integrated on the instrument) for data collection, processing and visualization.

Preliminary tests of the prototype on tourniquet-induced forearm ischaemia show adequate detectivity and time response. The operating parameters derived from the prototype will be employed in the design of a high channel count module, which will exploit the capabilities of a digital signal processor (DSP), for spatially mapped brain oxygenation monitoring.

**Keywords:** multichannel NIRS, LED, digital

## 1. INTRODUCTION

From an optical point of view, biological tissue can be considered as an absorbing matrix in which a high number of inhomogeneities, which act as light scatterers, are present<sup>1</sup>. When collimated near infrared (NIR) light is injected into the tissue and the collimated transmission is observed, light losses are mostly due to scattering rather than to absorption. In such wavelength region, the optical absorption is dominated by haemoglobin, the blood constituent that carries oxygen by fixing it in an oxygenated form (oxyhaemoglobin) and releasing it into the tissue, thus reverting to a deoxygenated form (deoxyhaemoglobin). The absorption spectra of haemoglobin<sup>2</sup> are reported in Fig. 1. We note that below 800 nm (isosbestic point) the absorption is strongly dominated by deoxyhaemoglobin, while above the isosbestic point oxyhaemoglobin absorption prevails. A small contribution to absorption is given by cytochrome aa<sub>3</sub>, another molecule involved in oxygen metabolism. Again, such molecule has an oxidized and a reduced form; a quantitative determination of the differential absorption spectrum may give information on tissue oxygen consumption. The last NIR absorption source, which should be taken into account for quantitative non-invasive spectroscopy on the tissue, is skin pigmentation; however, such absorption term does not change during the measurement.

\* Correspondence: Email: [mgiardini@smatteo.pv.it](mailto:mgiardini@smatteo.pv.it); Telephone +39 0382 503965; Fax +39 0382 503922

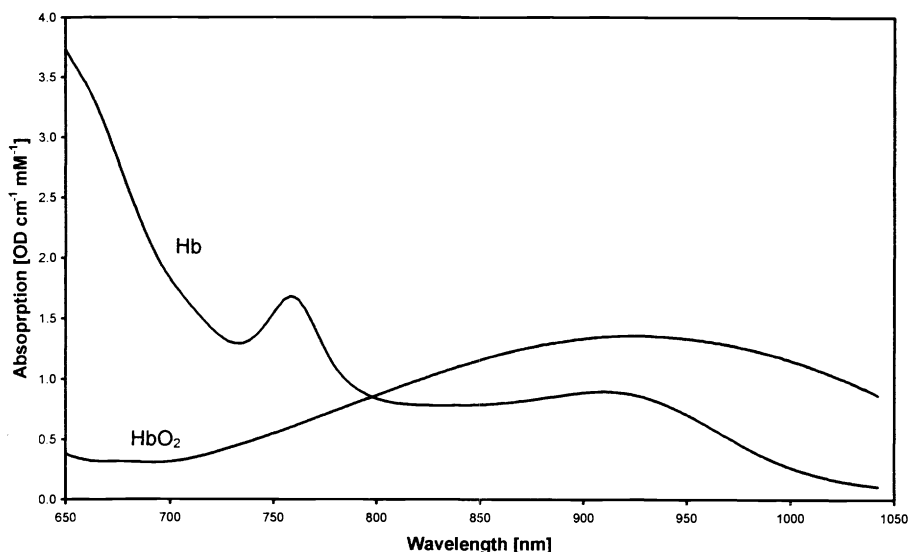

Fig. 1 – Oxyhaemoglobin (HbO<sub>2</sub>) and deoxyhaemoglobin (Hb) NIR absorption spectrum, from ref. 2.

While certainly simple from a theoretical and instrumental point of view, optical transmission requires a sampled volume, which should be transmissive enough to detect the transmitted light. Mainly because of scattering losses, this limits the application of direct transmissive measurements to small tissue thicknesses. In the last years, a number of instruments have therefore been constructed, which work on the optical spectrum analysis of the light backscattered by a depth of a few millimeters under the surface of thick tissue<sup>3,4</sup>. The technique is often generically referred to in the literature as Near Infrared Spectroscopy (NIRS).

Mainly because of the difficulties in the interpretation of the resulting signals<sup>5</sup>, the field is still very open to basic, clinical and instrumental research: protocol identification and correlation with clinical data are still the major problem to solve for a clinical applicability of the method. To this respect, a research-grade instrument specifically designed in the direction of the high flexibility required to satisfy an intensive clinical identification is commercially unavailable. Such an instrument should offer the opportunity to specialise the wavelengths, the number of measurement channels and the probe geometries with a minimum replacement of hardware components. It should also be able to collect, if needed, auxiliary signals such as bioelectric acoustic or pletysmographic signals, for synchronization purposes. In doing this, it should imperatively satisfy the basic patient safety requirements, as far as possible even when ill-verified prototype hardware is attached to it. And finally, it should require hardware prototyping techniques accessible to a standard prototyping laboratory. These are the guidelines from which a modular NIRS acquisition instrument, called IRIS for “InfraRed In-vivo Spectrometer” has been derived in the framework of the activities of The National Institute for Physics of Matter - Italy (INFN) and of the Clinical Engineering Division of IRCCS Policlinico S.Matteo, Pavia, Italy. In particular, in this paper the attention will be focused on one of its modules, based on a digital front-end, that constitutes a workbench for design optimization and performance factibility evaluation of a future high channel count instrument for NIR cerebral oxymetry measurements.

The acquisition system structure will be recalled here only briefly, as it will be described in detailed elsewhere<sup>6</sup>. IRIS consists basically of a PC-based acquisition system, mounted in a commercial mobile shielded 19 in. rack specifically designed for medical applications in clean and critical areas. The system is controlled by an industrial PC, in order to guarantee a shielding from electromagnetic interference sufficient to work in an operating theatre during surgery. The PC is connected via a dedicated addressable serial bus (RS232 timing, TTL levels, parallel addressing) to a modular front-end, which can carry up to 10 modules dedicated to NIRS or to other functions. The power supply to the system is designed to be patient-safe even in case of PC or module breakdown. A network connection permits a remote maintenance of the apparatus.

## 2. THE FRONT-END MODULE

The module is able to control four sources and two detectors. The standard configuration uses a probe with four different LEDs and the front-end is separated into two different sections: the analog section, completely shielded by a metal box, contains four amplification stages; one of these has variable gain and can be controlled by the user. The remaining part of the module is dedicated to sampling and digital processing; the heart of this digital section is a 33 MHz 8 bit RISC microcontroller (Microchip PIC17C44) with embedded RAM, ROM, UART (i.e. serial communications interface) and interrupt capabilities. The microcontroller is used to implement a 4-channel lock-in detection scheme and to control (through a digitally controlled potentiometer) the gain of one of the amplification stages. The lock-in<sup>7</sup> modulation technique can be used to single-out the component of the signal at a specific reference frequency and phase and to reject noise signals at frequencies other than the reference frequency.

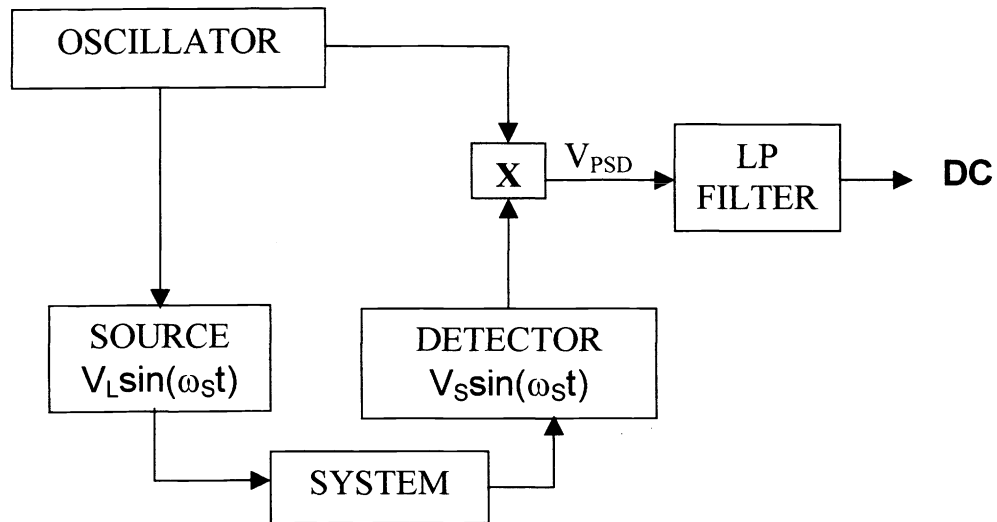

Fig.2 – Lock in scheme

If (Fig. 2) a system is excited by a sinusoidal oscillator  $V_L \sin(\omega_{st})$  and the system response  $V_S \sin(\omega_{st})$  is multiplied by the same sine wave, the resulting signal is:

$$V_{PSD} = V_S V_L \sin(\omega_{st}) \sin(\omega_{st}) = \frac{1}{2} V_S V_L - \frac{1}{2} V_S V_L \cos[2\omega_{st}] \quad (1)$$

Then at the output of LP filter the signal is:

$$V_{PSD} = \frac{1}{2} V_S V_L \quad (2)$$

that, as in standard homodyne, can be interpreted as a DC signal proportional to the amplitude of the system response (with a gain proportional to the oscillator amplitude). It can be shown that it is moreover possible to use a square wave, instead of a sinusoidal one, to modulate the source.

In our instrument we followed the scheme shown in Fig. 3, where the microcontroller (PIC17C44, Microchip Technology) controls all the steps of the lock-in process. The microcontroller generates the frequency signals for the source modulation. The signals (TTL square waves at about 1 kHz) are then fed to the probe through a connector. The probe drives the sources and the backscattered light is detected by the probe detector; the resulting signal is sent to the analog section of the module. On that section, the signal is amplified by a 3-stage AC-coupled variable gain amplifier and sampled by an 8-bit flash AD converter (Philips TDA8703). The microcontroller samples the AD converter and performs the multiply-accumulate operations shown in the figure.

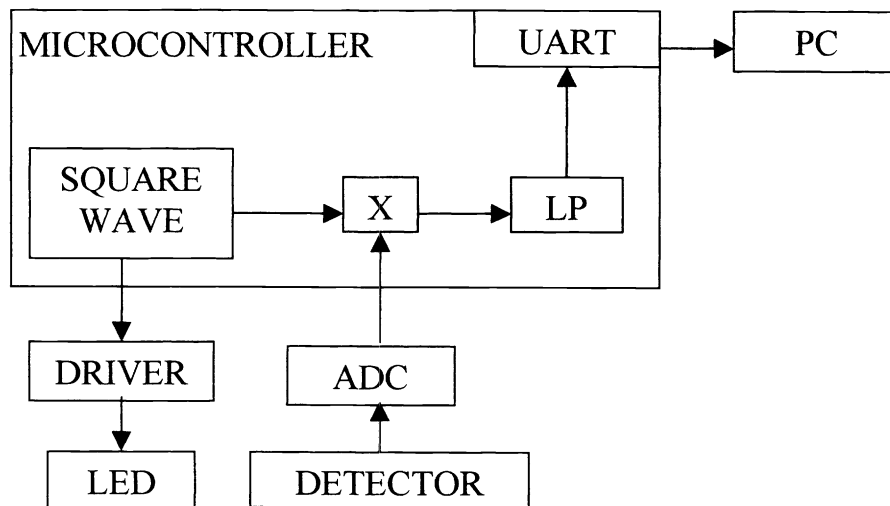

Fig. 3 – Digital lock-in implementation

The industrial workstation described above samples the lock-in accumulation results asynchronously from the lock-in process, interrogating the module via an interrupt generated by the UART integrated on the microcontroller. The workstation can also, using the same interrupt technique, automatically adjust the gain of the analog section of the module in order to keep the percentage of overflows on the ADC under a given value.

Using four sources and one detector (four source-detector channels) and working at 16 MHz, the instrument gives one value per channel every 250 ms. This can be considered a rate adequate for a clinically relevant number of applications of the instrument.

### 3. THE PROBE

The probe employed for the tests discussed later is represented in Fig. 4. It is divided in two independent sections, source and detection, both consisting in a head and in a proximity electronic module. The source and detection sections are separately connected to the system using 5 m long shielded cables terminated on both ends on simple metal-shielded D-9 connectors.

The head of the source section of the probe carries four plastic-case LEDs with peak wavelengths of 880, 850, 700 and 660 nm (Siemens HIRL 8810, Stanley DN304, Kingbright L53HD and Kingbright L53SRCE respectively). The LEDs are soldered to 50 cm high flexibility shielded cables and encapsulated with potting compound (Flexane 94, Devcon, U.K.) in separate 8 mm dia. plastic enclosures, which protect the solder joints from eventual aggressive cleaning processes and the patient from accidental electrical connection to the system. All the LEDs share the same D-9 connector.

The detection section of the probe has the same physical structure as the source section. An transimpedance-amplified plastic-case photodiode (Burr-Brown OPT201) is soldered to a high-flexibility 50 cm shielded cable and encapsulated with potting compound in a 15 mm dia. plastic housing. The detected signal is amplified by an amplifier housed in a small metal box interposed between the detector and the cable going to the module. The signal so preamplified, after an analog subtraction of the steady component of the background light, is fed directly to the amplifier-to-module cable.

Even though not specifically dedicated to any application, this probe configuration allows a large flexibility in the positioning of the sources and the detectors (in the literature often called “optodes”) on the patient. Even if the positioning flexibility of such a probe is too high to be practically employed in intensive clinical applications, it can be considered as an efficient workbench for future probe dimensioning and design.

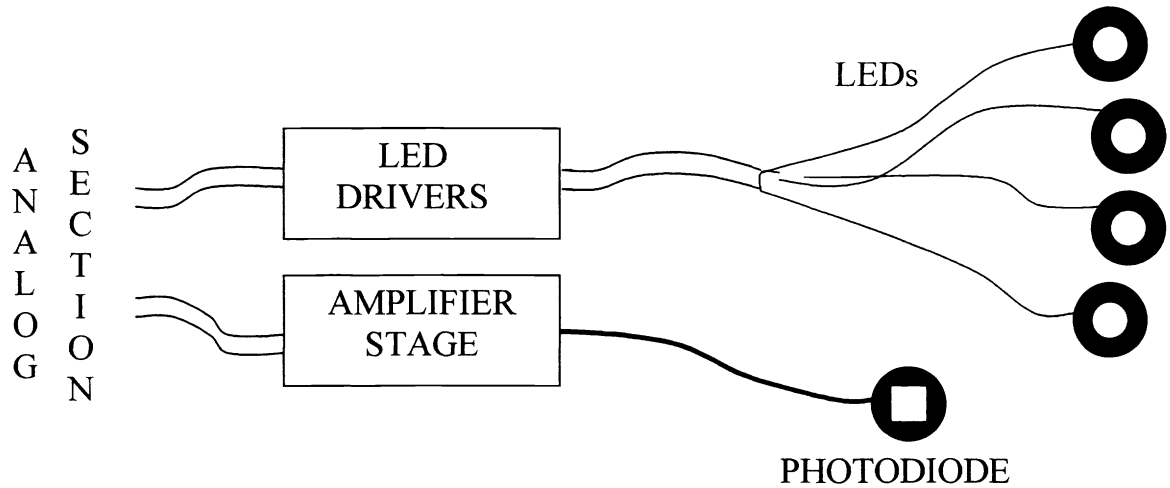

Fig. 4 - The probe

#### 4. PRELIMINARY PERFORMANCE TEST

The performance of the instrument has been tested on the well-known situation of a tourniquet-induced forearm ischaemia<sup>8</sup>. Such test is represented in Fig. 5. A patient is at rest, in a stationary state with respect to blood pressure, heart rate and muscle fatigue. A tourniquet is applied on the patient arm and inflated in order to shut off the blood supply to the forearm. During the ischaemia, oxygen consumption goes on and blood in the forearm is progressively deoxygenated. The forearm vessels respond to the deoxygenation by trying to increase the overall perfusion, hindered into this by the mechanical constraint that total blood volume must be kept constant by the occlusion. The tourniquet is then released, blood starts flowing again through the arm and oxygenation recovers its initial value. Since all volume constraints are removed, the vessels can increase their size, and so blood volume and oxygenation overshoot the stationary value, which is normally recovered a few minutes after ischaemia removal.

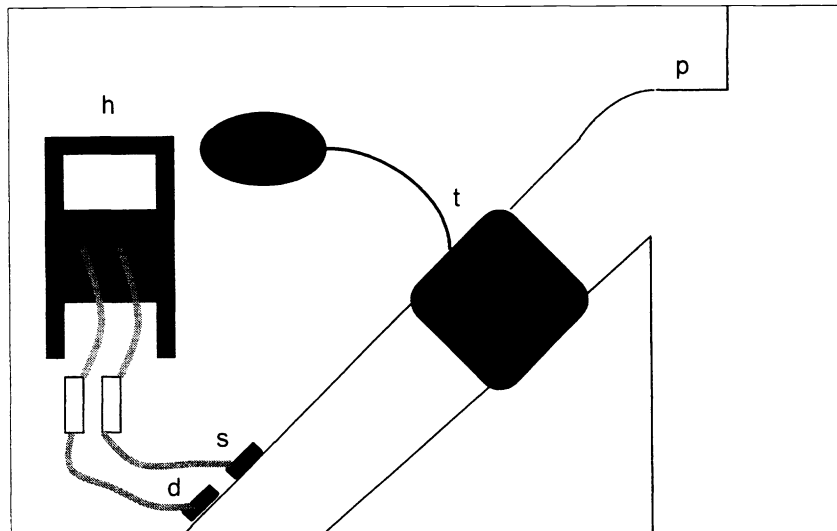

Fig. 5 – Tourniquet test: (m) main unit, (s) source probe, (d) detector probe, (t) tourniquet, (p) patient.

The test is presently being carried out on a set of healthy volunteers. In the current protocol the probe is fixed to a large forearm muscle interposing a drop of index-matching fluid and a point is accumulated and stored every second. An example of the signals measured on one of the subject, normalized to the initial values, is reported in Fig. 6.

A quantitative interpretation of the time behaviour of the ischaemic intensity curves is not within the scope of this paper, and still poses problems which are under active discussion in the literature. As far as it regards a direct observation of the signals, however, we note that the two signals at 660 and 700 nm (resp. 850 and 880 nm), whose dominating component is inversely related to deoxygenated (resp. oxygenated) haemoglobin blood content, follow a behaviour that agrees with the ischaemia description proposed in the preceding paragraph.

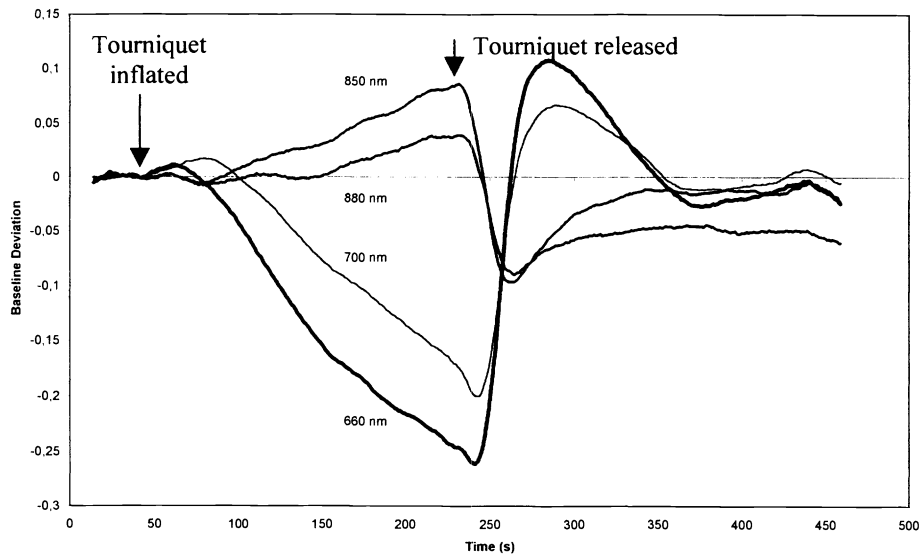

Fig. 6– Signals measured during forearm ischaemia.

## 5. CONCLUSIONS

A portable 4-channel NIRS acquisition system prototype has been briefly described in its overall structure, electronic and optical properties. The instrument has been tested on human forearm ischaemia and has shown adequate responsivity. The instrument here described meets the requirements of cost effectiveness, ease of use and intraoperative usability. Preliminary tests of the prototype on tourniquet-induced forearm ischaemia show adequate detectivity and time response. The operating parameters derived from the prototype suggest that the small number of components, none of which performing critical tasks, permits an easy replication of the module and, in particular, an easy increment of the source and detector number. Moreover, the maximum number of source-detector channels depends essentially on the processing speed of the microcontroller. These considerations clearly indicate that by employing a digital signal processor (DSP) as a substitute for the microcontroller, the channel count can be significantly increased.

## ACKNOWLEDGMENTS

We wish to thank C. Falcone (Dip. Cardiologia Univ. Pavia, Italy) for useful discussion and help during the clinical performance tests.

## REFERENCES

1. W Cheong, S.A. Prah, and A.J. Welch, "A Review of the Optical Properties of Biological Tissues", *IEEE J Quantum Elec* **26**, pp. 2166-2185, 1990

2. M. Cope, Ph.D. thesis, University College London, U.K., 1991
3. H. Owen-Reece, M. Smith, C.E. Elwell, and J.C. Goldstone, "Near Infrared Spectroscopy", *Br J Anaesth* **82**, pp. 418-426, 1999
4. J.A. Wahr, K.K. Tremper, S. Samra, and D.T. Delpy, "Near-Infrared Spectroscopy: Theory and Applications", *J Cardiothor Vasc Anaesth* **10**, pp. 406-418, 1996
5. S.J. Matcher, C.E. Elwell, C.E. Cooper and D.T. Delpy, "Performance Comparison of Several Published Tissue Near-Infrared Spectroscopy Algorithms", *Anal Biochem* **227**, pp. 54-68, 1995
6. To be published
7. M.L. Meade, *Lock-in amplifiers: principles and applications*, Perter Peregrinus, Exeter, 1983
8. N.B. Hampson and C.A. Piantadosi, "Near infrared monitoring of human skeletal muscle oxygenation during forearm ischemia", *J Appl Physiol* **64**, pp. 2449-2457, 1988