

Detoxification of water by semiconductor photocatalysis

By Soo-Keun Lee^a and Andrew Mills^{b*}

a: School of Environmental Science and Engineering, Pohang University of Science and Technology, Pohang, Korea 790-784

b: University of Strathclyde, 295 Cathedral Street, Glasgow, G1 1XL, UK. E-mail:

*a.mills@strath.ac.uk; * corresponding author*

Abstract

Introduction

A major initiative in the area of water and wastewater treatment, namely: semiconductor photocatalysis, has recently emerged. A number of major reviews of the academic literature associated with semiconductor catalysis have been reported [1-6]. There is also the recently-published, excellent on-line book entitled 'solar detoxification' (by semiconductor photocatalysis) [7]. Semiconductor photocatalysis has moved on since these reviews, so much so that commercial devices based on this technology are appearing on the international market. One area that appears particularly promising is the use of semiconductor photocatalysis for water purification and in this article the fundamentals of this technology and its current manifestations in the commercial world are explored.

In semiconductor photocatalysis, the light absorbing species is a semiconducting material. The electronic structure of most semiconductor materials comprises a highest occupied band full of electrons called the valance band (VB), and a lowest unoccupied band called the conductance band (CB). These bands are separated by a region that is largely devoid of energy levels and the difference in energy between the two bands is called the bandgap energy, E_{bg} .

Ultrabandgap illumination of such semiconductor materials produce electron-hole pairs, h^+e^- , which can either recombine to liberate heat, Δ , or make their way, via separate pathways, to the surface of the semiconductor material, where they have the possibility of reacting with surface absorbed species. Unfortunately, the efficiency-lowering process of recombination, either at the surface, or in the bulk of the semiconductor material, is the usual fate of photogenerated electron-hole pairs. Thus, the efficiencies of most processes involving semiconductor photocatalysis is low; typically $< 1\%$. This is particularly true in the case of amorphous semiconductor materials, since electron-hole recombination is promoted by defects. Consequently, in most of the current work involving photocatalysis, the semiconductor is comprised of microcrystalline or nanocrystalline particles and used in the form of a thin film or as a powder dispersion.

Photogenerated holes and electrons that are able to make their way to the surface of these semiconductor particles can either react directly, or indirectly through slightly less energetic trap surface states, with absorbed species. Thus, if there is an electron donor, D, adsorbed on the surface of the semiconductor particles, then the photogenerated holes can react with it to generate an oxidized product, D^+ . Similarly, if there is an electron acceptor present at the surface, i.e. A, then the photogenerated conductance

band electrons can react with it to generate a reduced product, A^- . The overall reaction can be summarized as follows:



A schematic representation of the energetics associated with the various processes involved in reaction (1) are illustrated in figure 1.

In the purification of water via semiconductor photocatalysis, the electron acceptor, A , is invariably dissolved oxygen, and the electron donor, D , is the pollutant, which is usually organic. Under these circumstances, the overall process is the semiconductor photocatalysed oxidative mineralisation of the organic pollutant by dissolved oxygen, and can be represented by the following equation:

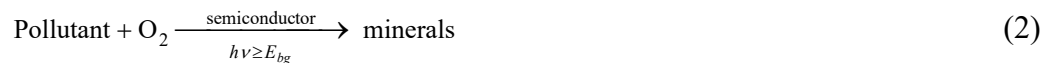

where 'minerals' are CO_2 , H_2O and, where appropriate, inorganic acids or salts, such as HCl or $NaCl$.

Ideally, a semiconductor photocatalyst for the purification of water should be chemically and biologically inert, photocatalytically active, easy to produce and use and, activated by sunlight. Not surprisingly, no semiconductor perfectly fits this demanding list of requirements, although the semiconductor titanium dioxide, TiO_2 , comes close, falling down on its inability to absorb visible light. In fact titanium

dioxide has a large bandgap energy, $E_{bg} \cong 3.2 - 3.0$ eV, and so is only able to absorb UV light (typically < 380 nm) which represents a small fraction, ca. 6%, of the solar spectrum. However, the other, very positive features of titanium dioxide as a semiconductor photocatalyst, such as high photoactivity, chemical and photochemical robustness and inexpense, far outweigh its deficient spectral profile overlap with the solar spectrum. As a result, titanium dioxide has become *the* semiconducting material for *research* and for use in commercial photocatalytic reactors in the field of semiconductor photocatalysis for water purification. Although titanium dioxide exists in three crystalline forms, namely: anatase, rutile and brookite, the common form used in semiconductor photocatalysis is anatase, as this is the most photocatalytically active and easiest to produce.

Mechanism and Reaction Kinetics

As noted above, in the photomineralisation of pollutants sensitised by titanium dioxide, i.e. reaction (2), the photogenerated electrons reduce water to oxygen and the photogenerated holes mineralize the pollutant. The latter process appears to involve the initial oxidation of surface hydroxyl groups ($> \text{Ti}^{\text{IV}} \text{OH}$) on the titanium dioxide to hydroxyl radicals ($> \text{Ti}^{\text{IV}} \text{OH}^{\bullet+}$), which then oxidize the pollutant, and any subsequent

intermediate or intermediates. The eventual final product is usually the mineral form of the pollutant, i.e. typically carbon dioxide, water, and, if a heteroatom is present in the pollutant under test, mineral acid. Photogenerated electrons can be trapped by surface sites, such as $\text{Ti}^{\text{IV}}\text{OH}$, to form Ti^{III} species, such as $\text{Ti}^{\text{III}}\text{OH}$, which can then react with dissolved oxygen to form superoxide, O_2^- . The latter species can be further reduced to hydrogen peroxide as an intermediate in the overall reduction of oxygen to water. Hydrogen peroxide is also a possible source of hydroxyl radicals, and it appears likely that during the course of reaction (2) some of the mineralisation of the pollutant is brought about by oxidizing species, such as hydroxyl radicals, that originate from the oxygen reduction process. The primary processes and associated characteristic time domains for semiconductor photocatalysis involving TiO_2 are listed in table 1 [3].

From this data it appears that the rate-determining step in the overall photocatalytic process is the reduction of dissolved oxygen by trapped photogenerated electrons, i.e. by $\text{Ti}^{\text{III}}\text{OH}$. Certainly the supply of oxygen to the particles can control the overall kinetics of the process [7-9]. However, the direct or indirect oxidation step involving the pollutant and the photogenerated holes is also a slow step and, under certain circumstances, can be rate-determining. Thus, the kinetics of semiconductor

photocatalysis for water purification are complex and often vary from one pollutant to another. Thus, when treated using semiconductor photocatalysis, a complex mixture of pollutants found in most waste streams is likely to produce an equally complex mixture of kinetics.

Interestingly, the kinetics of destruction of most simple *single* pollutant systems by semiconductor photocatalysis exhibit very similar features. Thus, the initial kinetics of photomineralisation of a general organic pollutant, P, by oxygen, sensitized by titanium dioxide, upon steady state illumination, usually fit a Langmuir-Hinshelwood kinetic scheme, i.e.

$$R_i = -d[P]/dt = k_p K_p [P] / (1 + K_p [P]) \quad (3)$$

where R_i is the initial rate of the substrate removal, $[P]$ is the initial concentration of the pollutant under test and, traditionally, K_p , is taken to be the dark Langmuir adsorption constant of species P on the surface of titanium dioxide. However, in general, it is usually found that the constant, K_p , is not directly equivalent to the dark Langmuir adsorption constant for P on the semiconductor and values for the latter parameter are usually found to be much smaller. Instead, semiconductor photocatalysis exhibits saturation-type kinetics that exhibit the same tendency as Langmuir-Hinshelwood kinetics but do not usually follow the mechanism associated with the equation [5, 10].

The parameter k_p is a proportionality constant which provides a measure of the intrinsic reactivity of the photo-activated surface with P. k_p is usually found to be proportional to I_a^θ , where I_a is the rate of light of absorption and θ is a power term which is equal to 0.5 or unity at high or low light intensity, respectively. The value of 0.5 for θ at high light intensities is attributed to the dominance of electron-hole recombination as the likely fate of the photogenerated electrons and holes. Under these conditions the steady-state concentrations of electrons and holes are proportional to $I_a^{0.5}$ and thus it is not surprising to find R_i is proportional to $I_a^{0.5}$. At very low incident light intensities the likelihood of electron-hole recombination is negligible and the steady-state concentration of electrons and holes is proportional to I_a and thus R_i is proportional to I_a . Note that as a consequence of the variation of θ with light intensity the reaction becomes less photon efficient the higher the light intensity. Indeed, in the limit, at very high light intensities, the kinetics become mass transfer controlled and independent of the intensity of the ultra-bandgap light, thus, R_i becomes independent of I_a .

The parameter k_p is also proportional to the fraction of oxygen adsorbed on titanium dioxide, i.e. $f(O_2)$,

$$f(O_2) = K_{O_2} [O_2] / (1 + K_{O_2} [O_2]) \quad (4)$$

where K_{O_2} is usually taken as the Langmuir adsorption coefficient for oxygen on the semiconductor, which appears to be non-competitively adsorbed.

A rough but useful guide to efficiency in semiconductor photocatalytic systems is photonic efficiency, δ , which is defined as follows:

$$\delta = \frac{\text{Overall rate of photocatalytic process}}{\text{Intensity of incident light}} \quad (5)$$

In semiconductor photocatalysis, the value of δ has often been found to approach unity, at low incident light levels of ultra-bandgap light. However, at the typical light levels generated by black light bulbs or germicidal lamps (*ca.* 6 mW cm^{-2} for an 8W lamp), the value of δ is usually *ca.* 0.01 for most semiconductor photocatalysis systems, as noted earlier. This low efficiency is due to a number of factors including reflection and scattering losses and significant electron-hole recombination at the light intensities typically found in most photoreactors (*i.e.* $0.1 - 10 \text{ mW cm}^{-2}$).

Several kinetic models of semiconductor photocatalysis have been developed with equations for the initial rate of semiconductor photocatalysis that conform to equations (3) and (4). Two of the most favoured mechanistic schemes involve either the attack of an adsorbed hydroxyl radical on the adsorbed pollutant, or the reaction of an adsorbed hydroxyl radical with a free pollutant molecule as the rate-determining step

[10]. However, recent work carried out by our group [11] and others [12] has shown that the parameters K_p and K_{O_2} in equations (3) and (4) are light intensity dependent, i.e.

$$K_p = K'_p I^\beta \quad (6)$$

where β is typically -1 . If, as is believed, this additional kinetic feature is found to be generally applicable to semiconductor photocatalysis, then a profound modification of the current kinetic models used to describe this process is required [12].

In semiconductor photocatalysis, an oft-employed test pollutant is 4-chlorophenol, 4-CP, and a typical test semiconductor photocatalyst is a dispersion of Degussa P25 TiO_2 , since the latter has a high specific surface area and high photocatalytic efficiency. Thus, a small amount it is able to destroy 4-CP quickly and efficiently.

Figures 2 and 3 illustrate the observed Langmuir-Hinshelwood type dependence of the initial rate of destruction of 4-CP by semiconductor photocatalysis, i.e. R_i , as a function of $[4-CP]$ and $[O_2]$, respectively. Figure 4 illustrates the observed variation in R_i as a function of incident light intensity for the same system and figure 6 illustrates the variation in the calculated value of K_{4-CP} as a function of incident light intensity. The solid lines in figures 2, 3, 4, and 5 are the lines of best fit to the data using equations (3), (4) and (6) and values for K_{4-CP} , k_{4-CP} , θ and β of $8.2 \times 10^3 \text{ dm}^3 \text{ mol}^{-1}$, $2.89 \times 10^{-6} \text{ mol dm}^{-3} \text{ min}^{-1}$, 0.60 and -1 , respectively [11,13]. The good fit of the data to equations (3) and

(4) are typical of that found in semiconductor photocatalysis for many pollutants using a TiO_2 semiconductor in dispersed powder or film forms.

Titanium dioxide, when used as a semiconductor photocatalyst in reaction (2), usually shows little or no appreciable loss in activity with repeated use. This feature of photochemical robustness and longevity is rather nicely illustrated by the data in figure 6, which shows the results of a typical set of successive kinetic runs in which 4-chlorophenol was mineralized by oxygen using titanium dioxide as the photocatalyst [14]. From the results of this work, it appears that even after 10 successive runs, the TiO_2 semiconductor photocatalyst shows little or no evidence of wear.

It should be recognized, however, that the results of experiments conducted in the field are often quite different from those in a laboratory. Most importantly, it is clear that a TiO_2 photocatalyst will not work very well, if at all, if the water under test contains any strongly UV absorbing pollutants, such as dye stuffs and humic acid. Nor will most photocatalysts work if metal ions, such as ferric and ferrous ions, are present and able to precipitate out as insoluble and inert oxides and hydroxides, onto the surface of the semiconductor material to form a passivating layer. Although the latter may be removed by using an acid wash, it appears a clear limitation of the technology. As a consequence, semiconductor photocatalysis, as a method of water treatment, is most

likely limited in application to water that has been prefiltered, to remove any solid material that is likely to deposit on the surface of the semiconductor and any strong UV-absorbing species that may be present, and, preferably deionised, so that it is fairly free of metal ions that may form insoluble oxides or hydroxides on the surface of the semiconductor.

Types of Pollutant

Research into semiconductor photocatalysis has largely focused on the removal of organic pollutants from water, since it appears that a wide range of such substrates are prone to complete mineralisation by dissolved oxygen, photosensitized by titanium dioxide. Table 2 provides a list of the wide number of classes of compounds, and examples of each, that have been shown to be completely mineralized by semiconductor photocatalysis using TiO_2 [5,6].

Notable compounds in table 2 include haloalkanes, such as chloroform, and tetrachloromethane, since they are carcinogens, and often found in small but detectable amounts in drinking water purified by chlorination. Indeed, it appears likely that semiconductor photocatalysis may find initial commercial application as an “after-chlorination” step in the production of drinking water . Other compounds listed in

Table 2 that are highly relevant to the treatment of waste water include: surfactants, hormones, herbicides, pesticides and dyes, all of which can be considered as relatively common pollutants from farms, households and/or industry. One of the very attractive features of semiconductor photocatalysis is its effectiveness against a broad range of pollutants, including those that are not easily removed by other water treatment processes, including chlorination. Semiconductor photocatalysis is ideal for treating refractory, hazardous, toxic and/or non-biodegradable pollutants.

In addition to the removal of organic pollutants, semiconductor photocatalysis has been used to sensitise the photoconversion of toxic inorganic substrates to harmless or less toxic ones, and a number of examples of such photoreactions, sensitized by titanium dioxide, are listed in table 3 [5]. Thus, semiconductor photocatalysis can be used to oxidize nitrite, sulphite and cyanide anions to form relatively harmless products, such as NO_3^- , SO_4^{2-} and CO_2 . Titanium dioxide is also able to photosensitise the decomposition of bromate, to bromide and oxygen, even when the level of bromate ions is as low as 50 ppb. Bromate is a carcinogen and is found in ppb levels in drinking water that has been purified by chlorinating a source water with a reasonably high background level of bromide ions. The removal of bromate ions at the ppb level

represents a major problem to the potable water production industry but semiconductor photocatalysis appears to offer a simple and effective solution [15].

Photoreactor Design

Photochemical reactor engineering is much more complex than chemical reactor engineering. For example, the type of radiation and the arrangement of the light source in the reactor system can dominate reactor design. In addition, the need for at least one of the reactor walls to transmit the chosen radiation requires the use of transparent materials, such as glass or silica, in reactor construction and this can cause limitations on size, and problems with sealing and breakage. The rate equations are also usually much more complex than those of traditional chemical processes, and we have seen already that semiconductor photocatalysis kinetics are complex enough! As a consequence, the overall equations describing the kinetics of the relevant photoprocesses, which are then used to optimize the reactor design, can often only be solved numerically, if at all [1, 16-18].

In heterogeneous semiconductor photochemistry, in contrast to the more traditional homogeneous photochemistry, the problem of reactor design is further complicated by the presence of a solid photocatalyst. From equation (2), it is clear that a reactor for

semiconductor photocatalysis has to be designed so that it can handle in an optimum way: the reaction solution, an oxygen gas stream, a solid photocatalyst and ultra-bandgap light.

With the large number of important parameters and phases associated with semiconductor photocatalysis the task of designing and characterizing a photoreactor for semiconductor photocatalysis can appear quite daunting. However, one starting point is the type of irradiation source, since the latter will influence considerably the subsequent design of the photoreactor itself. In most examples of semiconductor photocatalysis for water purification UV light is required and this can be obtained from arc lamps in which mercury and/or xenon vapour is activated electrically. Such lamps are usually very inefficient, in terms of UV photons produced per unit of electrical energy input, since a great deal of the electrical energy is converted into either heat or visible light. In addition, arc lamps are both expensive and have very limited lifetimes of operation, typically ca. 1000 h. In contrast, UV fluorescent lights are very efficient at converting electrical energy to UV photons, although their power, and therefore emitted light intensity, is usually quite small, upto 150 watts. Such lights utilise the 254 nm light emitted when an electrical discharge is passed through a low pressure vapour of mercury contained in a sealed tube. If no phosphor is coated on the walls of

the tube the product is a germicidal lamp. If a black-blue phosphor is coated onto the walls of the lamp, the product is a black light blue (BLB) lamp with an emission output of 365 ± 20 nm. Germicidal and black light bulbs are the most popular artificial light sources used in semiconductor photocatalysis.

The problem with germicidal lamps is that the light emitted is UVc light and, as a consequence, dangerous, e.g. it can cause skin cancer and blindness. In addition, the use of a UVc source requires the photoreactor to be built with a quartz window to allow the transmission of the UVc light to the reaction solution. Black light lamps, on the other hand, emit UVa light and, as a result, pose much less of a risk to biological systems. However, the commonly used photocatalyst, titanium dioxide, absorbs 365 ± 20 nm light much less (typically by a factor of 10) than it does germicidal light [19]. As a consequence, TiO_2 photocatalytic systems are more likely to reflect and scatter incident UVa light, as well as absorb it, when compared to UVc light and, as a result, are likely to be less efficient in terms of photons. A major advantage of using black light blue lamps over germicidal lamps is that the photoreactor can be constructed from cheap sodium borosilicate glass, which transmits light of wavelengths greater than 300 nm, rather than expensive quartz, which cuts off at 200 nm. The relatively high UV light to electrical energy conversion efficiencies of both germicidal and black light

bulbs, typically 10-20%, and their long operational lifetimes, typically 4000-14000 hours, makes these the preferred light sources for use in photoreactors for semiconductor photocatalysis.

It is worth reminding oneself at this point that in all semiconductor photocatalytic systems for water purification, the reaction solution needs to be purged continuously with either air or oxygen for the system to work efficiently, as indicated in equations (2) and (3). Failure to do so can lead to oxygen starvation of the system and a catastrophic loss of efficiency for the overall photoreaction (2) [7-9]. Thus, the issue of a good and continuous supply of oxygen to the system needs to be addressed when designing any reactor for semiconductor photocatalysis.

Most research work into semiconductor photocatalysis use batch photoreactors, with a reaction solution, comprising the test pollutant and a dispersion of the semiconductor photocatalyst, with the process of oxygen sparging being carried out in the photoreactor itself prior to or throughout the irradiation process. In contrast, in many flow systems, this purging process has to be carried out in a reaction solution reservoir that is separate to the photoreactor. The exception to these general cases of added oxygen is thin film photoreactors, since the gas exchange between air and the reaction solution is usually sufficiently facile, and the kinetics of photocatalysis so slow, that no additional sparging

of the reaction solution with oxygen or air is required. In some closed, usually annular, photocatalytic reactor systems, concerns about the level of oxygen may be such that an additional electron scavenger, such as hydrogen peroxide or sodium persulphate, is added to improve the overall efficiency of pollutant destruction. However, in general the more reagents that have to be added, the more esoteric and less practical any water purification becomes, including ones based on semiconductor photocatalysis.

When designing a photoreactor for semiconductor photocatalysis an early decision that needs to be made is the form the semiconductor photocatalyst is to take. Most of the research carried out into semiconductor photocatalysis for water purification has been conducted using titanium dioxide powder dispersions. The use of the resulting dispersions/slurries obviously necessitates a subsequent separation step involving either filtration, centrifugation, or coagulation/ flocculation. This added step, or steps, increases the complexity of the overall process and decreases its economic viability [3]. However, slurry reactor photocatalytic systems are usually very efficient in terms of photons, when compared to thin film reactors at least, and easier to make and maintain. Thus, such systems continue to be attractive.

In contrast, photocatalytic reactors that utilize a fixed bed of semiconductor material, are usually much less photon-efficient for pollutant destruction, due to an intrinsic low

surface area to volume ratio. In addition, such systems are difficult to make, can be difficult to maintain, especially if passivation of the photocatalyst occurs, and are costly to replace. However, the major advantage of such fixed film photoreactors is that no subsequent separation step is required. These and other key positive and negative features of dispersed and fixed film photocatalytic reactors are listed in table 4.

As noted earlier, most of the reactors used to conduct research on semiconductor photocatalysis for the purification of water are operated in batch, rather than continuous mode. Figure 7 illustrates some of the numerous designs that have been used in such photochemical research.

In most of the early research work on semiconductor photocatalysis, the semiconductor was used in the form of powder particles dispersed throughout the reaction solution containing the pollutant under test. The simplest and earliest photocatalytic reactors comprised a glass reactor vessel, containing the reaction solution under test, dispersed with semiconductor photocatalyst particles, and either an external light source as illustrated in figure 7(a), or a lamp immersed in the reaction solution (see figure 7(b)).

Another photoreactor for semiconductor photocatalysis is an annular system, i.e. figure 7(c), in which the reaction solution passes along the reactor length one or more times. This latter reactor geometry is very popular in the water disinfection industry. The

circular photoreactor, illustrated in figure 7(d), is also used in semiconductor photocatalysis research and allows the use of many low energy, low intensity UV lamps to achieve a high radiant flux. In this photoreactor the reaction solution can be flowed, or operated in batch mode and stirred.

As an alternative to using the semiconductor photocatalyst in the form of a dispersion of powder particles it is possible to fix it to an inert substrate, such as glass, to produce a fixed bed photoreactor. One of the earliest types of fixed bed photocatalytic reactors is illustrated in Figure 8(a) [20, 21]. In this system the semiconductor photocatalyst is coated onto the inner walls of a glass spiral that has a UV fluorescent lamp along its central axis. The contaminated water passes down the glass spiral over the irradiated photocatalyst, where mineralisation of the pollutant(s) occurs. Since such a system has a low photocatalyst surface area to reaction solution volume it is likely to be quite inefficient and thus such photoreactors are usually operated in multi-pass, or series, mode, in order to effect the complete mineralisation of the organic pollutant under test. Work by Ollis and his co-workers has shown that this type of spiral fixed bed photoreactor is prone to exhibit kinetics that are largely mass transfer dependant and, thus, far from optimal [22]. The combination of low surface area to reaction volume

ratio and mass transfer kinetics makes this reactor system very unattractive for either research or industrial scale up.

One way to improve the surface area to reaction volume ratio in a fixed photocatalytic film reactor is to use supported semiconductor photocatalysts, rather than films on the reactor walls [23]. Supported semiconductor photocatalysts comprise a thin layer of the semiconductor material attached, chemically or physically, to a high surface area inert support material, such as alumina pellets, molecular sieve, glass fibre or ceramic membranes. Figure 8(b) illustrates a typical example of a supported fixed-bed system, comprising an annular photoreactor packed with glass fibre impregnated with fine TiO_2 particles [21].

Ultimately, the support materials can be made so fine that they behave as powder dispersions and therefore require a subsequent filtration step. However, a bit before this extreme lies the realm of semiconductor particle sizes that are neither too small and nor too large to create problems of either filtration or low photocatalytic efficiency, respectively. Thus, these particles (typically 0.5-5 micron diameter) are sufficiently small that they still offer a reasonable specific surface area but are sufficiently large to be dense enough to readily settle out under gravity even in the presence of a reasonable flow of reaction solution. Under such circumstances the photocatalyst particles can be

used in a fluidized bed and require no subsequent filtration step. An example of such a reactor has been reported recently, in which the support material was 0.3 mm diameter sand particles and the deposited semiconductor was TiO₂ [24]. The basic features of such a fluidized bed, fixed (onto the support particles) photocatalytic film reactor, are illustrated in figure 8(c).

One of the major problems in semiconductor photocatalysis is the achievement of a uniform distribution of light in the photoreactor. When the semiconductor photocatalyst is used in the form of a dispersion of powder particles, or coated on an inert support material such as glass beads, alumina pellets etc, the distribution of light throughout the reaction vessel is likely to be non-uniform, due to absorption, reflection and scattering by the support as well as the active photocatalyst coating. Obviously, a poor distribution of UV light in a semiconductor photocatalytic reactor will lead to a low overall efficiency of operation. Figure 8(d) illustrates a novel system for distributing the ultra-bandgap light more evenly in a photoreactor [25]. In the general form of this system, the photocatalyst material is dispersed throughout the photoreactor as a coating on a series of light conductors, such as thin glass plates, rods, fibres or hollow glass tubes [26-29]. Such dispersed light and photocatalyst systems achieve a high surface area to reaction volume ratio and a more even distribution of the number of

photons impinging on the, usually, fixed, catalyst particles in the reactor. One of the problems of such light distribution photoreactors is that the light conductors would have to be made out of expensive quartz if germicidal lamps rather than black light lamps were to be used as the light source. An even distribution of light in a photoreactor can also be achieved by using a number of very thin germicidal or black light lamps, coated with photocatalyst in much the same arrangement of glass rods/fibres as illustrated in fig. 8(d) [27, 28]. Such light tubes are just entering the market and are likely to find great application in this area provided their cost is low.

One of the most likely manifestations of a reactor for semiconductor photocatalysis for water purification is one in which the semiconductor photocatalyst is fixed onto the walls of the photoreactor and exposed to a thin falling film of the reaction solution.

A good example of such a photoreactor is illustrated in Figure 9(a) and can be used with the semiconductor either fixed onto the walls of the reaction vessel, or dispersed in the falling film of reaction solution [30-33]. As noted earlier, with such thin, (reaction solution) film photoreactors the rapid exchange of oxygen between air and the thin reaction solution film makes it unnecessary for the latter to be pre-purged with air. In addition, such photocatalytic reactors allow the ready use of germicidal lamps as the irradiation source and renders the whole system more photon-efficient, since the

absorption coefficient of TiO_2 at 254 nm is very high [19]. A novel variation of the thin falling film photoreactor is illustrated in figure 9(b) [34]. In this system the fixed photocatalytic film is coated on a drum of glass that is half dipped into the reaction solution under test and half in air. The system is irradiated from above. Rotation of the photocatalyst-coated glass drum produces a thin film of reaction solution over the fixed photocatalytic film coating the drum. The result is a thin film, fixed bed photoreactor that allows the ready destruction of any pollutants present by semiconductor photocatalysis using, for example, UVc light. Once again, no pre-purging of the reaction solution with air or oxygen is necessary in such a system.

Recently, Yue and his co-workers have reported a novel fountain photocatalytic reactor for the purification of water [35, 36]. In this system a fountain of reaction solution, containing the pollutant and a dispersion of semiconductor photocatalyst particles is continuously generated and the fountain head is irradiated with ultra-bandgap light. The basic features of this system are illustrated in Figure 9(c). Such a system obviously does not require any additional purging with air or oxygen and does have the benefit of a high photocatalyst surface area per unit volume of reaction solution and minimal mass transfer limitations. However, as with all slurry type reactors, a photocatalysis recovery system is required.

Of course, one way to lessen the cost of a photocatalytic system for water purification is to use that 'free' light source, the sun. Numerous solar reactors for water purification via semiconductor photocatalysis have been reported [7, 37-40]. Such systems can be non-concentrating and so utilize direct and diffuse sunlight, although typically the UV flux will be limited to that of one sun, i.e. ca. 0.04 mW cm^{-2} [39]. Note that this level of UV light is about 150 times less than from an 8W UV fluorescent lamp. Fig. 10(a) illustrates a typical non-concentrating falling film solar photoreactor for water purification. Building such a photoreactor is not trivial since it needs a large area of weather-resistant, chemically inert, cheap, UV light-transmitting glazing. In addition, careful control of the reaction solution is required, especially if the photocatalyst is used in slurry, rather than fixed bed, form [39].

Figure 10(b) illustrates the basic features of a parabolic photoreactor, which allows any incident sunlight to be concentrated on the reaction solution [38, 39]. Such parabolic units, when collected together, form a compound-parabolic-concentrator, i.e. a CPC. A CPC allows more expensive components, usually supported photocatalysts, to be used in the construction of the photoreactor without adversely affecting the overall cost. When compared to a non-concentrating photoreactor, a CPC has a higher light-captivity efficiency and, therefore, will occupy a smaller area under one sun operation [38]. In a

CPC the bank of reflectors are usually inclined, facing south, but do not actively track the sun. Obviously, not all places in the world are sunny enough to justify using a solar powered system. As a result, most solar-powered water purification systems will be limited to areas where the solar UV irradiation is $> 0.015 \text{ mW cm}^{-2}$, i.e. typically between latitudes 35°N and 35°S .

Both non-concentrating and concentrating solar reactions can be operated using the photocatalyst as a slurry (moving film) or a fixed film. The former often appears to be the preferred embodiment in concentrating solar systems, because of the high surface area to reaction solution volume ratio it affords, despite the need for a subsequent separation step. However, as indicated by equation (3) and noted earlier, the kinetics of semiconductor photocatalysis will be proportional to $I^{0.5}$ at high UV levels. As a result, most concentrating (i.e. high UV light intensity) solar systems for water purification are not as photon-efficient, i.e. have a lower value of δ , than most non-concentrating solar photoreactors. The higher photon efficiencies of non-concentrating solar photocatalytic reactors, and their added ability to capture diffuse UV sunlight, makes these systems the most cost-effective for purifying water using sunlight. Any waste water solar-powered detoxification process will most likely be run in batch mode with the solution recirculated until the levels of pollutants are at an acceptable low level

for discharge. All solar detoxification systems must work independent of the process generating the waste and, as a result, are unlikely to be used for on-line waste water treatment.

Commercial Systems

Semiconductor photocatalysis is still quite young with regard to commercialization and this may appear slightly surprising given the intense level of academic research that has been conducted over the last decade. It appears that, despite its promise as an advanced oxidation process, capable of mineralizing a wide range and number of water-borne pollutants, the overall low efficiency of operation of current laboratory and pilot-scale systems is insufficiently attractive to encourage their major utilisation by any of the major water purification companies. This low overall efficiency derives from a number of factors, some of which have been mentioned before, but which are outlined below for completeness.

To start with, most UV lamps have modest (10-20% at best) electrical energy to UV light energy conversion efficiencies. However, despite this inefficiency, UV light disinfection of water is already a well-established method in the water treatment industry. Thus, coating the reactor walls of any commercial annular UV

photodisinfection system with TiO_2 should improve its overall efficiency, given the photo-induced antibacterial action of TiO_2 . It is slightly surprising, therefore, that this option has not been the subject of intensive research by any of the big water UV-disinfection companies.

The overall process of semiconductor photocatalysis is itself intrinsically low (typically $< 10\%$), mainly due to significant electron-hole recombination at the typical light intensities used in this work. In practice, the overall photonic efficiencies of most photocatalytic systems are very low (i.e. $< 1\%$) due to additional efficiency-lowering processes, such as light scattering and reflection, and mass transfer effects.

The most efficient and cheapest to produce photocatalytic systems use the semiconductor in the form of a powder dispersion, but such systems then require a subsequent filtration step which instantly compromises the system's economical viability. Fixed-bed photocatalytic reactors appear to offer an attractive alternative to dispersed photocatalyst systems, but their initial construction costs are comparatively high. In addition, with such fixed-bed systems, if regular photocatalyst replacement is necessary, due to some passivation process, then maintenance costs are likely to prove prohibitive.

Although semiconductor photocatalysis appears to be rejected at present by most major water purification and disinfection companies as an economically viable alternative to current methods, such as chlorination and ozonolysis, it *has* been taken up by companies and government agencies, which have small, specific water purification needs, such as those found in the electronics industry (high purity water) and the dye and car manufacturer industries and the military and petrochemical industries (especially for effluent or site clean-up).

Table 5 lists most of the major companies that currently promote and sell semiconductor photocatalysis systems for water purification. The table also includes examples of relevant patents and references to the company web-sites. Not surprisingly, a good number of the companies listed in table 5 appear to have ‘products’ that are still very much in the development stage. Thus, the Japanese company ISK is a major manufacturer of titanium dioxide and has a US patent on water purification, using porous titanium dioxide containing inorganic particles, but does not appear to have a semiconductor photocatalyst water purification product as yet. Instead, ISK, like many others, has conducted some initial research and may develop a product some time in the future. Similarly, the environmental engineering company Hyosung Ebara, based in Korea, has an established track record in the management of waste water and,

on its web site, identifies semiconductor photocatalysis as one of the advanced oxidation processes it has available at its disposal. However, Hyosung Ebara also does not appear to have a major commercial product at the present time.

Given the substantial academic interest in the area of semiconductor photocatalysis, it is not surprising to find that two companies, namely Clearwater Industries, and Photox Bradford, have university origins, i.e. the University of Florida and the University of Bradford, respectively. Clearwater Industries claim to be able to treat over 2250 litres per minute of contaminated water using their semiconductor photocatalyst water purification system, R2000. Although there are very few details on the web site concerning the workings of the R2000 solar oxidation system, it appears that it is a fixed photocatalyst bed reactor and, unlike all other commercial photocatalytic water purification systems, it utilizes the UV component in sunlight to drive the photocatalytic mineralisation process, rather than an artificial UV source. In Gainesville, Florida, a Clear Water Industries R2000 Solar Oxidation facility was used to treat a 500 gallon aquifer contaminated with BTEX (benzene, toluene, ethyl benzene and xylene). This solar-driven system was able to reduce the level of BTEX to well below 65 ppb within 3h even on a cloudy day and could work at a rate ranging from 19-19000 litres per minute.

As with Clearwater Industries, Photox Bradford appears to be a small company that is creating custom-built, small scale photoreactors for water purification. In contrast to the Clearwater Industries R2000 solar oxidation system, the Photox™ system utilizes a slurry of titanium dioxide in which the particles are sufficiently large that a standard, off-the-shelf, separator can be used to remove and return to the photoreactor from the purified water. The Photox™ system claims to be able to treat 168 litres per minute of contaminated water. Linntech Inc. is yet another small company with a patented small scale, fixed bed, PCO reactor for water purification.

All the semiconductor photocatalyst water purification companies discussed so far are very much overshadowed by Purifics® Environmental Technologies Inc., a Canadian based water purification company dedicated to the application of semiconductor photocatalysis for the purification of water. The Purifics® system, called Photo-Cat®, utilizes the titanium dioxide in the form of a slurry. The basic components of this system are illustrated in figure 11. The system comprises pre-filters, to remove any fine solid material, a coalescor, to remove any emulsified oils or greases above 7 microns in size, the Photo-Cat® Reactor, to photomineralise the pollutants, and the CRU (Catalyst Recovery Unit), to continuously separate the photocatalyst particles from the treated water and return the former to the inlet stream of the reactor and the

latter to the effluent stream. The titanium dioxide is used in unsupported, i.e. neat powder, dispersed form. The Photo-Cat® Reactor uses long-lasting (14000 h) low pressure mercury fluorescent lamps, i.e. germicidal lamps and the TiO₂ slurry plus polluted water is contained in a set of stainless-steel tubes, connected together to form a series of racks. These racks are, in turn, linked together in serial and/or parallel mode depending upon the concentration of contaminants and the required throughput.

From the associated patents, see table 5, it appears that in the Photo-Cat® reactor each reactor tube is an annulus type reactor, see fig. 7(c), with a central germicidal lamp surrounded by a quartz tube and a subsequent outer stainless-steel tube; the TiO₂ slurry and polluted solution are flowed through the annulus gap between the walls of the quartz and stainless-steel tubes. The size of the gap is typically less than 1 mm, to ensure a high degree of turbulence, due to shear stress from the flowing reaction solution, which in turn ensures that mass transfer effects will be minimal. Also from the associated patents, the key Catalyst Recovery Unit, CRU, appears to be a cross-flow type filtration system using a ceramic (alumina) membrane (pore size: 0.2 microns) and a trans-membrane pressure of ca. 10 psi. Usually the pores of such a membrane would be quickly blocked by the photocatalyst particles, but this is prevented by the application to the ceramic filter of a 0.5 s shock wave (150 psi) typically every 5 min

from the effluent side. The photocatalyst powder used in the Photo-Cat® is cheap (\$1) and can be changed within 30 min. The lamps are relatively inexpensive (lamps costs are estimated at \$85 per kW of system size per year) and can be changed within 30 s. Purifics® claim that their Photo-Cat® system is not affected by iron fouling, since by lowering the solution pH to 3 or less, the Photo-Cat® system keeps any iron dissolved in the aqueous phase.

The overall system is essentially a solid-state device that can be operated unattended for long periods of time. The manufacturers claim that the amount of TiO₂ supplied with the system will last the expected lifetime of the unit, although it is not clear what the unit's lifetime is. Purifics® is the largest supplier of industrial photocatalytic treatment systems and has found markets in the USA, Canada and Korea. Most of these systems have been used to treat contaminated ground water, however, a few have been used to treat industrial wastewater, lagoons and air.

Thus, at a petrochemical waste site in Galveston, Texas, a 19 kW Photo-Cat® system was used to reduce the level of bis (2-chloroethyl) ether, the main pollutant, from 200 ppm to 20 ppb at a rate of 15-30 litres per minute. In Ontario, Canada, a Photo-Cat® system was used to treat continuously 30 000 gallons per day from three wells

contaminated with TCE, DCE, DCA, TCA, vinyl chloride, oil and grease, present in the ppm range.

Comparison with Other Water Purification Systems

Table 6 highlights some of the important features of the major destructive methods that are currently used by the big water companies to purify water, and compares them with those of semiconductor photocatalysis. From this table it is clear that the latter process has a number of advantages compared with the other, more established destructive water purification processes, but is not rapid in action, nor easy to use/maintain, nor cheap to buy.

More useful comparisons need to be made, using independent data obtained from side-by-side studies of both solar and artificial light driven semiconductor photocatalytic systems and various popular conventional waste water treatment processes. Only when such work has been carried out will the real potential of semiconductor photocatalysis as a commercially-viable alternative method of water purification be understood and possibly appreciated. As it stands, the research results look promising but the transformation from a wonderful idea two decades ago to a vibrant commercial reality appears to be slow. Over the next few years it will become apparent if

semiconductor photocatalysis has a real future in water-purification. It has certainly begun to make inroads into the commercial scene, albeit into niche markets. It appears to have the potential to become a major player in the water purification industry, but, without a major breakthrough, in the current market it appears likely that cost and low efficiency issues may well prove its downfall. All will become apparent in the next few years.

References

1. D.F. Ollis, and C. Turchi, *Environ. Prog.* **9**, 229 (1990).
2. D.F. Ollis, E. Pelizzetti and N. Serpone, *Environ. Sci. Technol.* **25**, 1523 (1991).
3. M.R. Hoffmann, S.T. Martin, W. Choi and D.W. Bahnemann, *Chem. Rev.* **95**, 69-96 (1995).
4. A. L. Linsebigler, G. Lu, and J.T. Yates, *Chem. Rev.* **95**, 735 (1995).
5. A. Mills and S. Le Hunte, *J. Photochem. Photobiol. A:Chem.* **108**, 1 (1997).
6. D.S. Bhatkhande, V.G. Pangarkar and A.A.C.M Beenackers, *J. Chem. Technol. Biotechnol.* **77**, 102 (2001).
7. J. Galvez and S. M. Rodriguez, Online publication: <http://www.unesco.org/science/wsp/publications/solar.htm>, (2002).
8. N.S. Foster, C.A. Koval, J.G. Szechowski, and R.D. Noble, *J. Electroanal. Chem.* **406**, 213 (1996).
9. S. Upadhia and D.F. Ollis, *J. Phys. Chem.* **101**, 2625 (1997).
10. C.S. Turchi. and D.F. Ollis, *J.Catal.* **119**, 483 (1989).
11. A. Mills and J. Wang, *Z. Phys. Chem.*, **213**, 49 (1999).

12. A.V. Emeline, V. Ryabchuk, and N. Serpone. *J. Photochem. Photobiol. A: Chem.* **133** 89(2000).
13. A. Mills and S. Morris, *J. Photochem. Photobiol. A: Chem.* **71** 75 (1993).
14. G. Al-Sayyed, J.C. D'Oliveira. and P. Pichat, *J. Photochem. Photobiol. A: Chem.* **58** 99 (1991).
15. A. Mills, A. Belghazi and D. Rodman, *Wat. Res.* **30**, 1973 (1996).
16. A.M. Braun, In *Photocatalysis and Environment*. Schiavello (ed.), Kluwer Academic Publishers, Amsterdam, 601 (1988).
17. A.E. Cassano and O.M. Alfano, In *Photochemical Conversion and Storage of Solar Energy*. Pelizzetti, E. and Schiavello, M. (Eds.), Kluwer Academic Publishers, Amsterdam, 623 (1991).
18. P.S. Mukherjee, and A.K. Ray, *Chem. Eng. Technol.* **22**, 253 (1999).
19. A. Mills, S.-K. Lee, A. Lepre, I.P. Parkin and S.A. O'Neill, *Photochem. Photobiol. Sci.*, **1**, 865, 2002.
20. R.W. Matthews, *J. Phys. Chem.* **91**, 3328 (1987).
21. R.W. Matthews, *Solar Energy* **38**, 405 (1987).
22. C.S. Turchi and D.F. Ollis. *J. Phys. Chem.* **92**, 6852 (1988).

23. J.F. Porter and P.L. Yue, In *Photocatalytic Purification and Treatment of Water and Air*. Ollis, D.F. and Al-Ekabi, H. (Eds.), Elsevier Science, Amsterdam, 759 (1993).
24. A. Haarstrick, O.M. Kut and A. Heinzl, *Environ. Sci. Technol.* **30**, 817 (1996).
25. K. Hoffstadler, R. Bauer, S. Novalic and G. Heisler, *Environ. Sci. Technol.* **28**, 670 (1994).
26. N.J. Peill and M.R. Hoffmann, *Sci. Technol.* **29**, 2974 (1995).
27. N.J. Peill and M.R. Hoffmann, *Environ. Sci. Technol.* **30**, 2806 (1996).
28. A.K. Ray, *Chem. Eng. Sci.* **54**, 3113 (1999).
29. A.K. Ray and A.A.C.M. Beenackers, *Catal. Today.* **40**, 73 (1998).
30. H.C. Yatmaz, C.R. Howarth and C. Wallis, In *Photocatalytic Purification and Treatment of Water and Air*. Ollis, D.F. and Al-Ekabi, H. (Eds.), Elsevier Science, Amsterdam, 795 (1993).
31. G.L Puma and P.L. Yue, *Chem. Eng. Sci.* **53**, 3007 (1998).
32. G.L. Puma and P.L. Yue, *Ind. Eng. Chem. Res.* **38**, 3246 (1999).
33. G.L Puma and P.L. Yue, *Environ. Sci. Technol.* **33**, 3210 (1999).
34. A. Toyoda, L. Zhang, T. Kanki and N. Sano, *J. Chem. Eng. Jpn.* **33**, 118 (2000).

35. G.L. Puma and P.L. Yue, *Chem. Eng. Sci.* **56**, 2733 (2001).
36. G.L. Puma and P.L. Yue, *Ind. Eng. Chem. Res.* **40**, 5132 (2001b).
37. C.S. Turchi and D.F. Ollis, *J.Catal.* **122**, 178 (1990).
38. R.W. Matthews, *Wat. Res.* **20**, 569 (1986).
39. C. Turchi, M. Mehos and J. Pacheco, In *Photocatalytic Purification and Treatment of Water and Air*, D.F. Ollis and H, Al-Ekabi, (Eds.), Elsevier, Amsterdam, 789 (1993).
40. N. J. Peill and M.R. Hoffmann, *J. Solar Eng.* **119**, 229 (1997).

Table 1: Primary processes and associated characteristic time domains in the TiO₂-sensitised photomineralisation of organic pollutants

Primary Processes	Characteristic Times
<i>charge-carrier generation</i>	
$\text{TiO}_2 + h\nu \longrightarrow \text{h}^+ + \text{e}^-$	fs (very fast)
<i>charge-carrier trapping</i>	
$\text{h}^+ + >\text{Ti}^{\text{IV}}\text{OH} \longrightarrow \{\text{>Ti}^{\text{IV}}\text{OH}^{\bullet+}\}$	10 ns (fast)
$\text{e}^- + >\text{Ti}^{\text{IV}}\text{OH} \longleftrightarrow \{\text{>Ti}^{\text{III}}\text{OH}\}$	100ps (shallow trap; dynamic equilibrium)
$\text{e}^- + >\text{Ti}^{\text{IV}} \longrightarrow >\text{Ti}^{\text{III}}$	10 ns (deep trap)
<i>charge-carrier recombination</i>	
$\text{e}^- + \{\text{>Ti}^{\text{IV}}\text{OH}^{\bullet+}\} \longrightarrow \text{>Ti}^{\text{IV}}\text{OH}$	100ns (slow)
$\text{h}^+ + >\text{Ti}^{\text{III}}\text{OH} \longrightarrow >\text{Ti}^{\text{IV}}\text{OH}$	10 ns (fast)
<i>interfacial charge transfer</i>	
$\{\text{>Ti}^{\text{IV}}\text{OH}^{\bullet+}\} + \text{organic pollutant} \longrightarrow >\text{Ti}^{\text{IV}}\text{OH} + \text{oxidised pollutant}$	100ns (slow)
$\{\text{>Ti}^{\text{III}}\text{OH}\} + \text{O}_2 \longrightarrow >\text{Ti}^{\text{IV}}\text{OH} + \text{O}_2^{\bullet-}$	ms (very slow)

Table 2: Some examples of TiO₂-sensitised photomineralisation of organic substrates

Class	Examples
Alkanes	methane, <i>iso</i> -butane, pentane, heptane, cyclohexane, paraffin
Haloalkanes	mono-, di-, tri- and tetrachloromethane, tribromoethane, 1,1,1-trifluoro-2,2,2-trichloroethane
Aliphatic alcohols	methanol, ethanol, <i>iso</i> propyl alcohol, glucose, sucrose
Aliphatic carboxylic acids	formic, ethanoic, dimethylethanoic, propanoic, oxalic acids
Alkenes	propene, cyclohexene
Haloalkenes	perchloroethene, 1,2-dichloroethene, 1,1,2-trichloroethene
Aromatics	benzene, naphthalene
Haloaromatics	chlorobenzene, 1,2-dichlorobenzene, bromobenzene,
Nitrohaloaromatics	3,4-dichloronitrobenzene, dichloronitrobenzene,
Phenols	phenol, hydroquinone, catechol, 4-methyl catechol, resorcinol, <i>o</i> -, <i>m</i> -, <i>p</i> -cresol
Halophenols	2-, 3-, 4-chlorophenol, pentachlorophenol, 4-fluorophenol, 3,4-difluorophenol
Aromatic carboxylic acids	benzoic, 4-aminobenzoic, phthalic, salicylic, <i>m</i> - and <i>p</i> -hydroxybenzoic, chlorohydroxybenzoic acids
Polymers	polyethylene, PVC
Surfactants	SDS, polyethylene glycol, sodium dodecyl benzene sulphonate, trimethyl phosphate, tetrabutyl ammonium phosphate
Herbicides	methyl viologen, atrazine, simazine, prometon, propetryne, bentazon
Pesticides	DDT, parathion, lindane
Dyes	methylene blue, rhodamine B, methyl orange, fluorescein, reactive black 5

Table 3: TiO₂ sensitised photosystems for the removal of toxic inorganics

Overall Reaction	
A	D → A⁻ + D⁺
5O ₂ + 6NH ₃	→ 2N ₂ + N ₂ O + 9H ₂ O
O ₂ + 2NO ₂ ⁻	→ 2NO ₃ ⁻
O ₂ + 2SO ₃ ²⁻	→ 2SO ₄ ²⁻
2O ₂ + H ₂ O + S ₂ O ₃ ²⁻	→ 2SO ₄ ²⁻ + 2H ⁺
O ₂ + 2CN ⁻	→ 2OCN ⁻
5O ₂ + 4H ⁺ + 4CN ⁻	→ 2H ₂ O + 4CO ₂ + 2N ₂
2BrO ₃ ⁻	→ 2Br ⁻ + 3O ₂

Table 4: Features of dispersed and fixed film photocatalyst particle reactors

Feature	Dispersed semiconductor photocatalyst	Fixed-film semiconductor photocatalyst
Ease of photocatalyst preparation	Excellent. Photocatalyst easily prepared, by numerous chemical routes, including hydrolysis or air oxidation of simple Ti(IV) precursors.	Can be difficult and usually involves either CVD, sol-gel, sputtering or thermal oxidation methods
Ease of replacement of the semiconductor photocatalyst	Excellent. Simply add the photocatalyst particles to the polluted water stream.	Often difficult as the usually firmly fixed film photocatalyst is often attached to the walls of the photoreactor. Photocatalyst on support materials, such as glass beads, are easier to change.
Overall ease of operation as a water purification system	Not usually very good since a subsequent particle separation step is required which usually brings with it the need for regular filter replacement. In addition, ideally the filtered photocatalyst should be returned to the photoreactor which poses another technical problem, although a recirculation system with cross filtration appears to offer a solution. System need constant sparging with air.	Excellent. No filtering needed. In some 'closed-to-the-ambient air' systems, oxygen sparging is really needed.
Efficiency per m ²	High due to high photocatalyst surface area to reaction solution ratio and no mass transfer effects.	Low, thus, such systems need to be cheap per m ²
Cost	Low initial outlay but maintenance costs can be high	High initial outlay but maintenance costs could be low, provided the water stream does not contain any deactivating contaminants.

Table 6: TiO₂ photocatalyst systems for the purification of water

Company	Country	Patents	Comments	Web Site
Ishihara Sangyo Kaisha (ISK)	Japan	US5541096	Large TiO ₂ manufacturer, Tipaque®, with a patent on water purification using photocatalysis and a novel, porous catalyst.	www.iskweb.co.jp
Hyosung Ebara	Korea	JP 2000237759	Major water purification company with designs for a semiconductor photocatalyst water purification systems but no obvious products	www.heec.co.kr
Clear Water Industries	USA		Small company with Florida University origins. Flat bed semiconductor photocatalyst reactor can treat 2250 l min ⁻¹ .	www.cwirfc.com
Photox Bradford Ltd.	UK		Small company with Bradford University origins. Its semiconductor photocatalyst reactor uses the TiO ₂ as a slurry and can treat 168 l min ⁻¹ .	www.vcb.co.uk/photox/
Lynntech Inc.	USA	US5779912	A small company selling a fixed bed semiconductor photocatalyst reactor	www.lynnotech.com
Purifics® Environmental Technologies Inc.	Canada	US6136203 US5589078 US5462674	Manufacturers of the Photo-Cat® water and air automated treatment system and largest supplier of industrial semiconductor photocatalyst treatment systems	www.purifics.com

Table 6: Comparison of destructive water purification methods

Method:	UV	O₃	UV-O₃	Cl₂	SPC
Features					
Destroys chlorinated hydrocarbons	×	✓	✓	✓	✓
Total pollutant mineralisation usual	×	×	✓	×	✓
Broad compound compatability	×	✓	✓	✓	✓
Use non-hazardous oxidant	✓	×	×	×	✓
Simple to use	✓	✓	✓	✓	×
Rapid pollutant destruction	×	✓	✓	✓	×
Low operating costs	✓	×	×	✓	✓
Low initial equipment costs	✓	×	×	✓	×

Figure 1. Schematic illustration of the energetics of semiconductor photocatalysis.

Figure 2. Plot of the measured initial rate of disappearance of 4-CP, R_i , as a function of [4-CP]. The results were obtained using a batch reactor containing: 4-CP (100 cm^3), $[\text{O}_2] = 100\%$ saturated, TiO_2 (Degussa P25, 0.5 mg cm^{-3}), $\text{pH} = 2$ and $T = 30^\circ\text{C}$. Data after [11].

Figure 3. Plot of the measured relative rates of carbon dioxide production as a function of $[\text{O}_2]$. The results were obtained using a batch reactor containing: 4-CP (100 cm^3 , $10^{-3} \text{ mol.dm}^{-3}$), TiO_2 (Degussa P25, 0.5 mg cm^{-3}), $\text{pH} = 2$ and $T = 30^\circ\text{C}$. Data after [13].

Figure 4. Plot of the measured initial rate of disappearance of 4-CP, R_i , as a function of relative incident light intensity. The results were obtained using a batch reactor containing: 4-CP (100 cm^3 , $5 \times 10^{-4} \text{ mol.dm}^{-3}$), $[\text{O}_2] = 100\%$ saturated, TiO_2 (Degussa P25, 0.5 mg cm^{-3}), $\text{pH} = 2$ and $T = 30^\circ\text{C}$. Data after [11].

Figure 5. Plot of the measured value of $K(4\text{-CP})$ as a function of incident light intensity. The values of $K_{4\text{-CP}}$ were obtained from plots of R_i versus [4-CP] and subsequent analysis using eqn (3). Data after [11].

Figure 6. [4-CP] versus time profile recorded for 10 successive mineralisation cycles using the same TiO_2 photocatalyst dispersion. The dotted vertical lines correspond to

the readjustment of the [4-CP] to $1.55 \times 10^{-4} \text{ mol.dm}^{-3}$, followed by a 20 min. dark period so that adsorption equilibrium could be obtained. Data after [14]

Figure 7. Basic common photocatalytic slurry reactor designs including: side views: (a) reactor with external illumination, (b) immersion; top views: (c) annular (i.e. tubular with negative illumination geometry) and (d) circular.

Figure 8 Fixed (including supported) photocatalyst film reactors including: (a) spiral, (b) annular, (c) fluidized bed and (d) light distribution reactors.

Figure 9 Examples of thin falling film photocatalytic reactors including: (a) classic tubular, (b) rotating drum and (c) fountain photoreactors. Note all can be used with the photocatalyst fixed to the reactor walls (fixed bed) or as a dispersion (moving bed) in the reaction solution.

Figure 10 Basic solar photocatalytic reactor designs including: (a) non-concentrating, thin falling film and (b) concentrating parabolic trough reactors.

Figure 11 Schematic representation of the basic features of a Photo-Cat® reactor sold by Purifics Inc. The unit comprises: prefilters, a coalescor, a photocatalyst unit, a CRU (catalyst recovery unit) and a pH adjuster feed on the effluent channel. This unit can be fully automated.

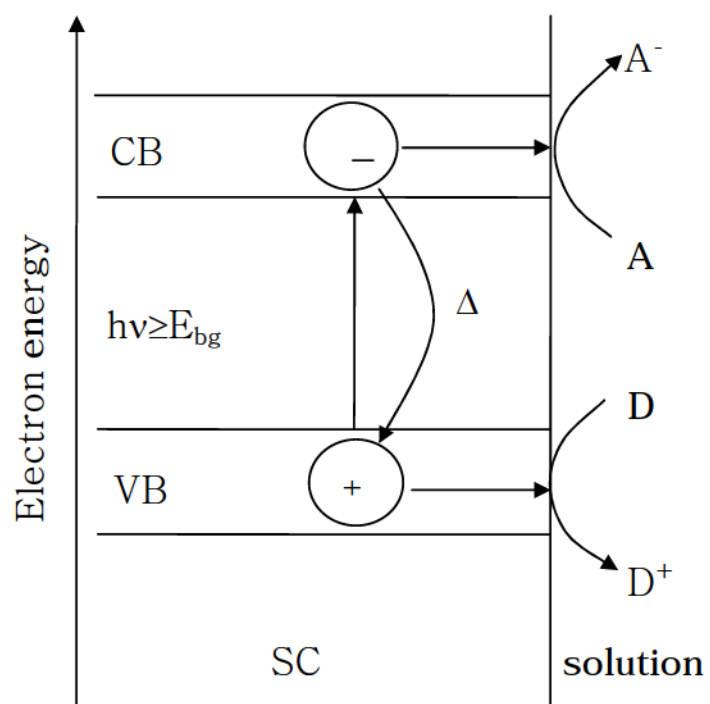

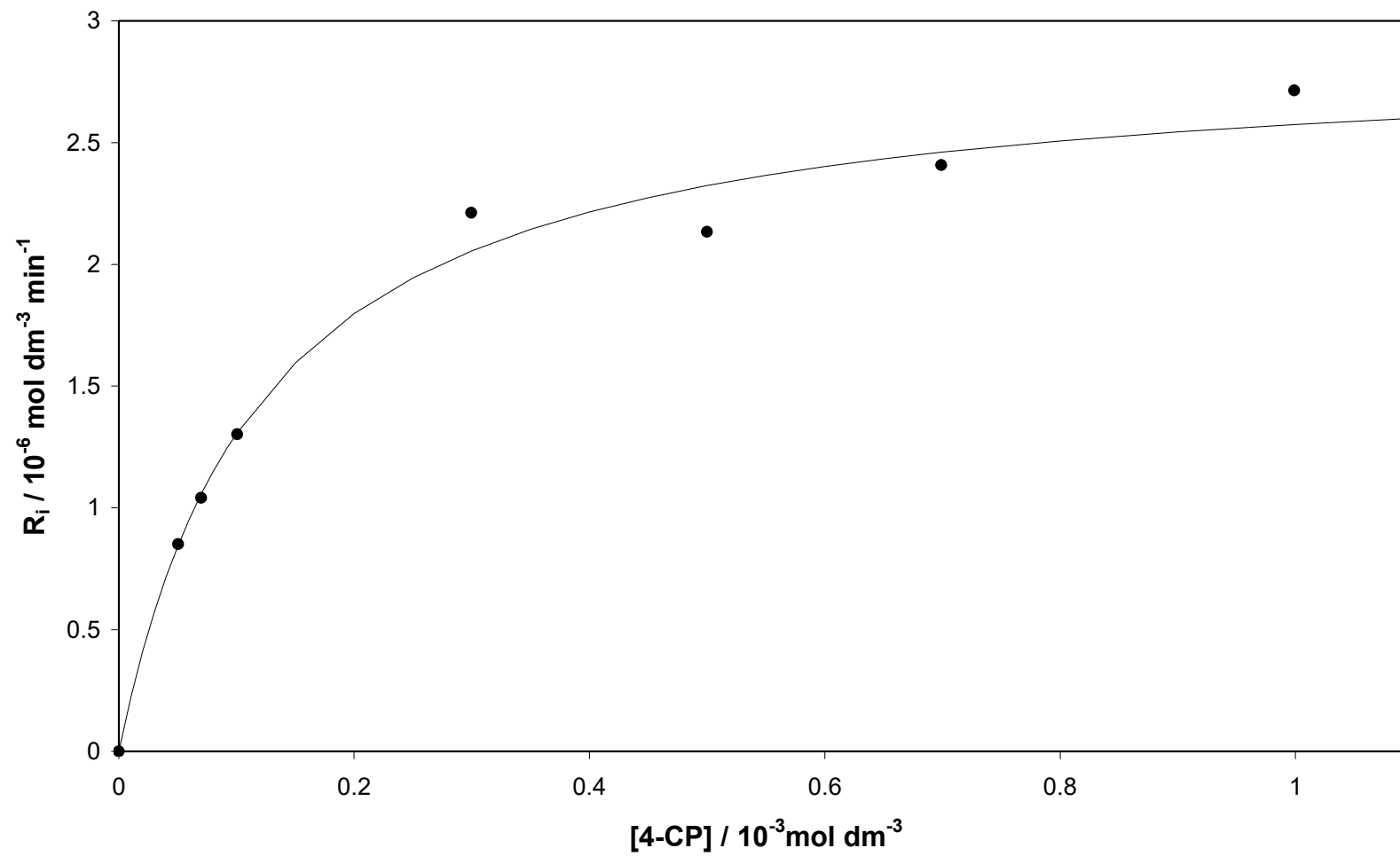

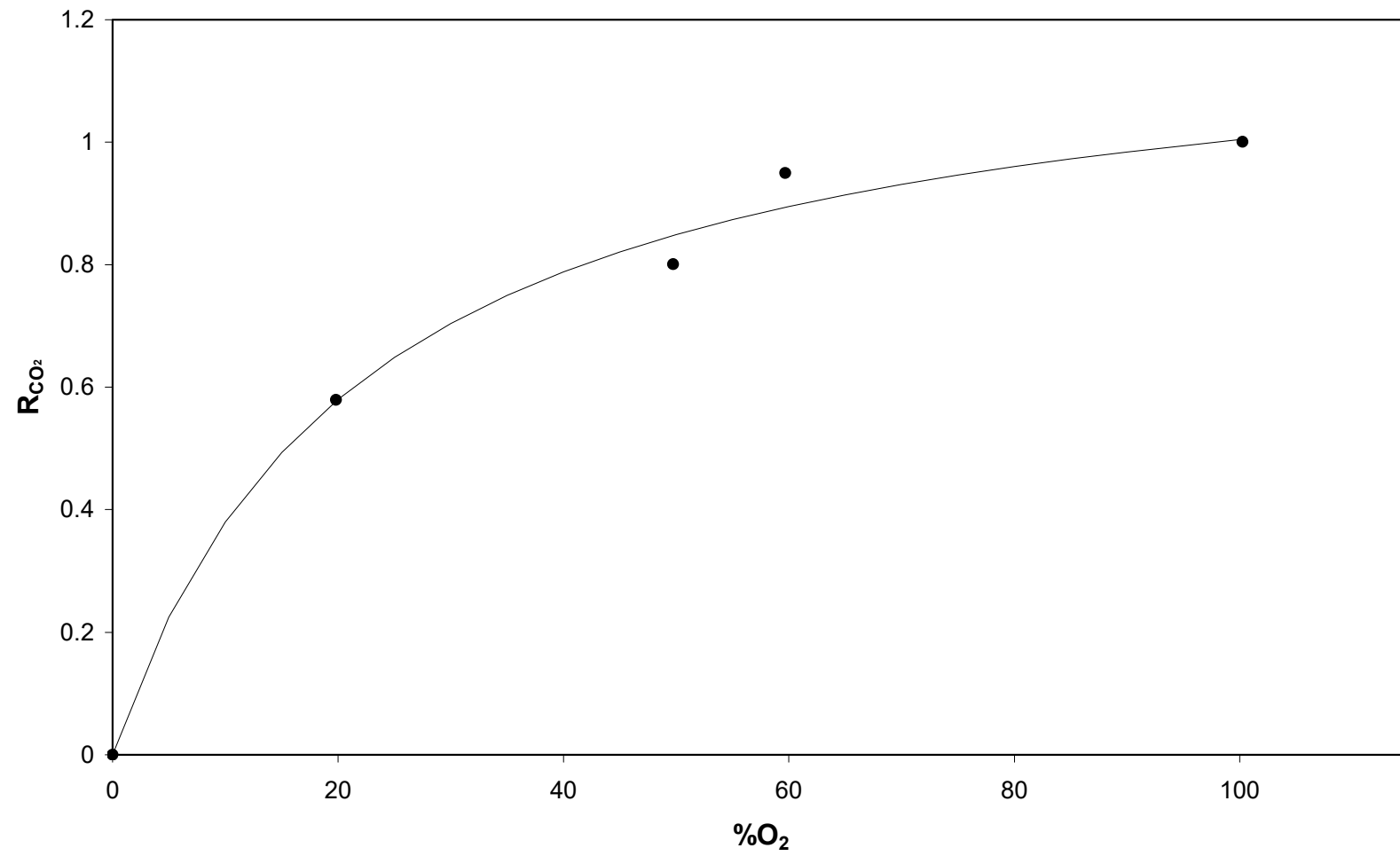

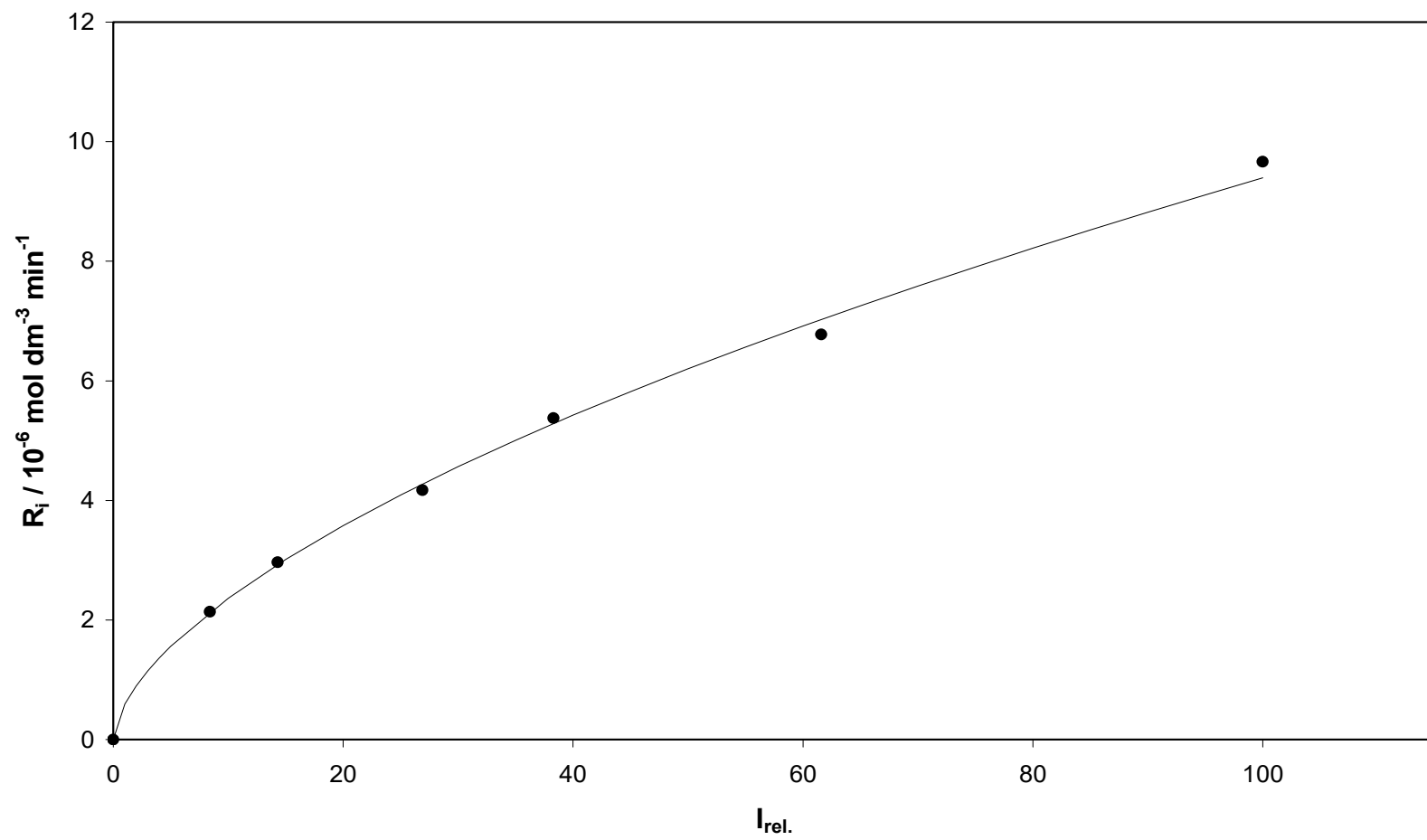

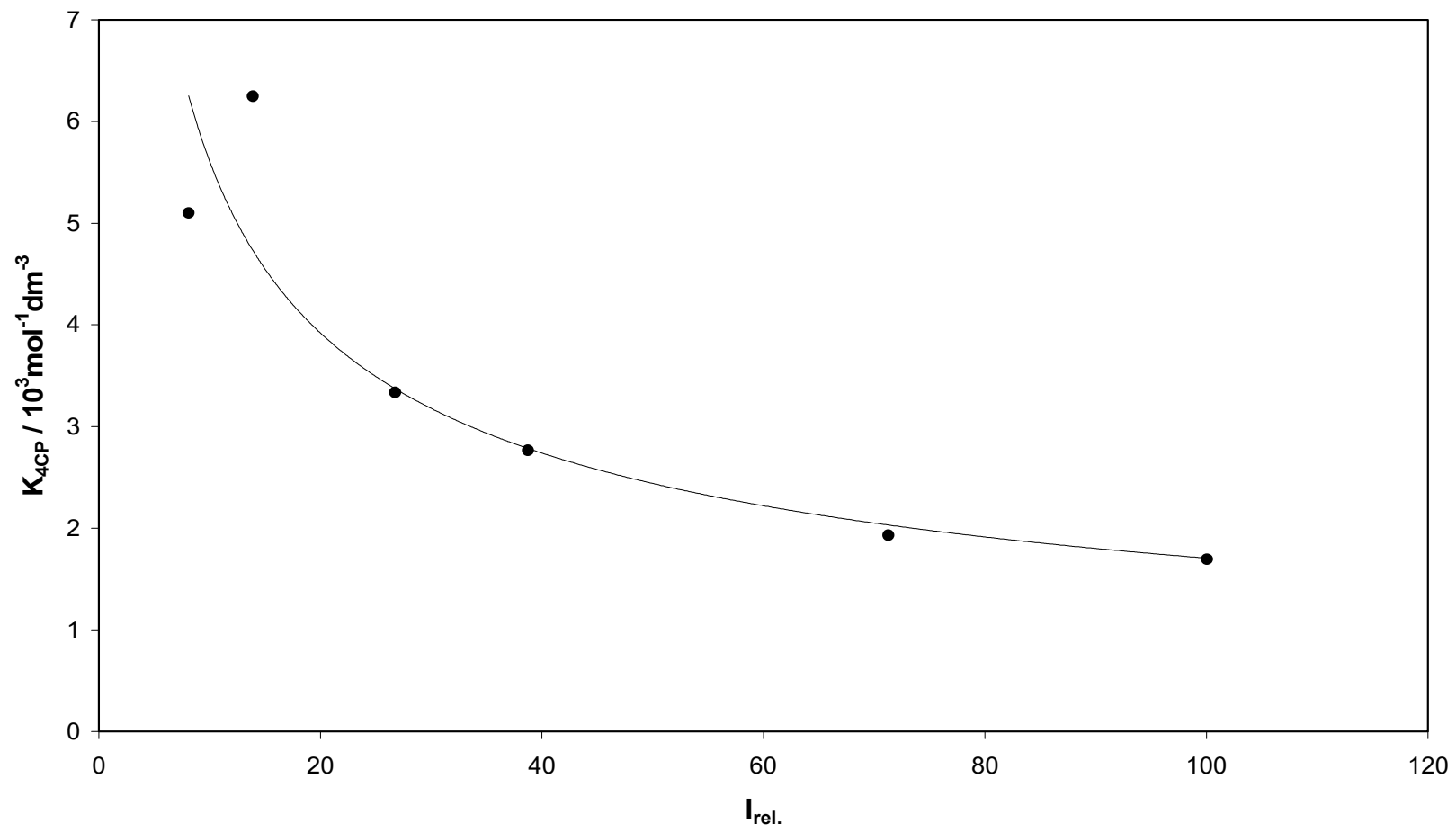

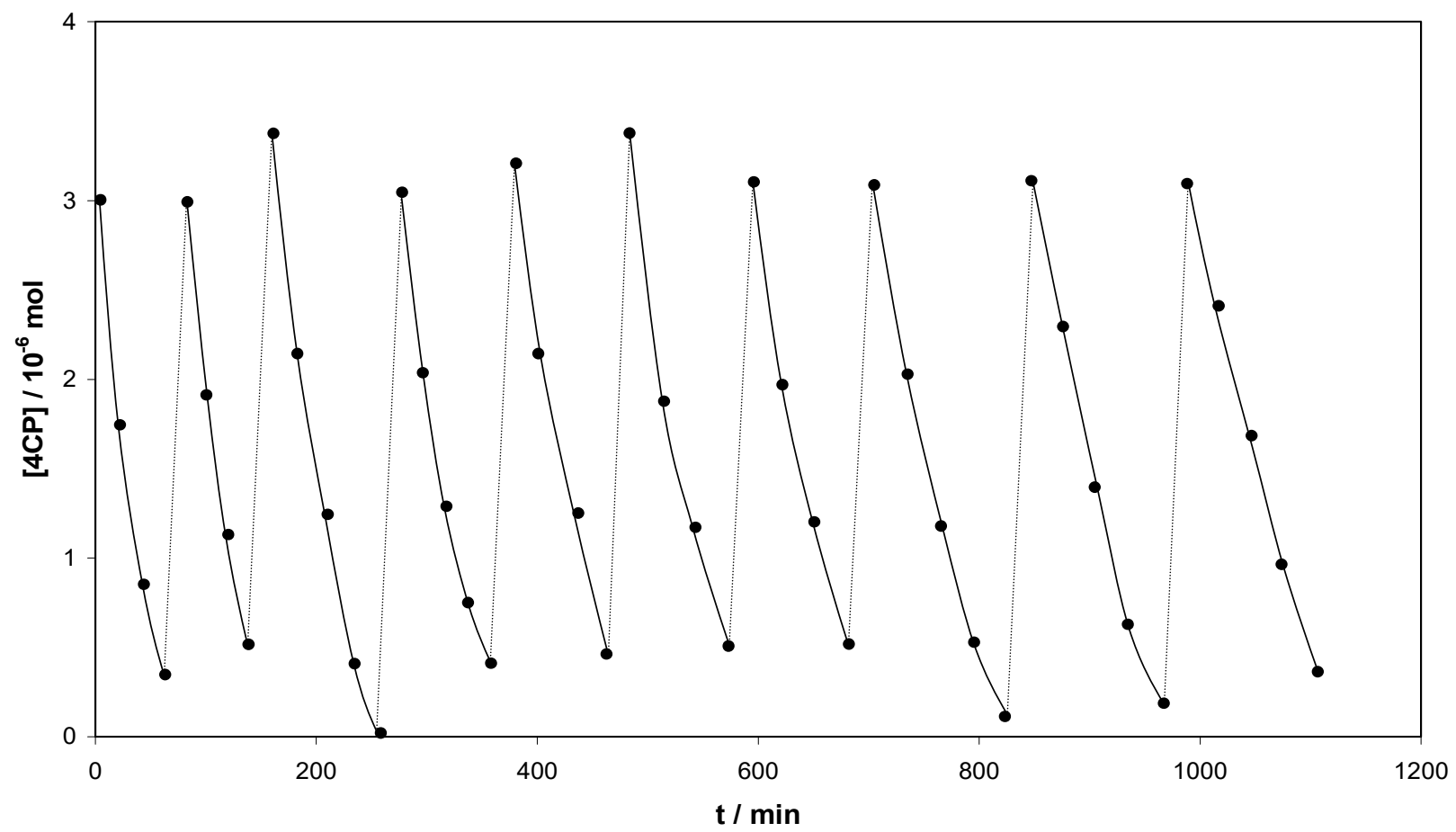

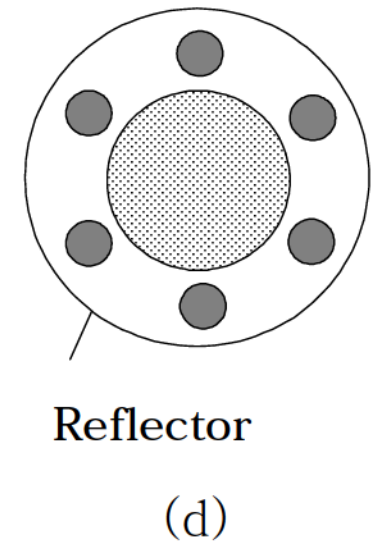
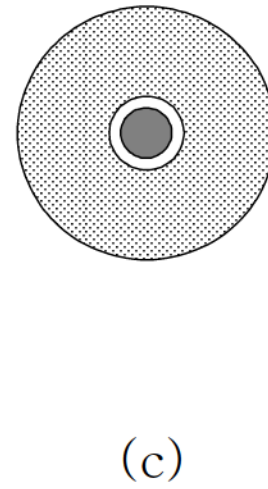
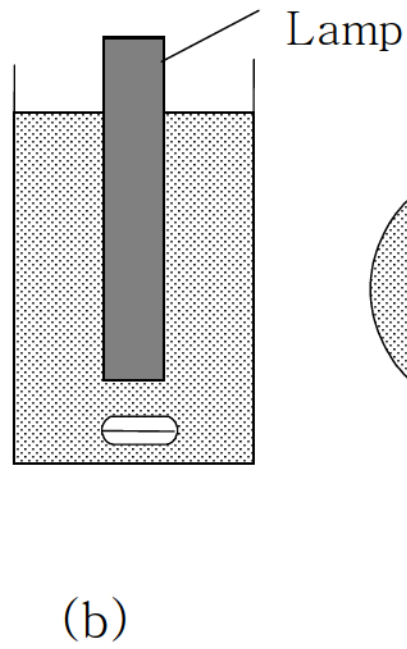
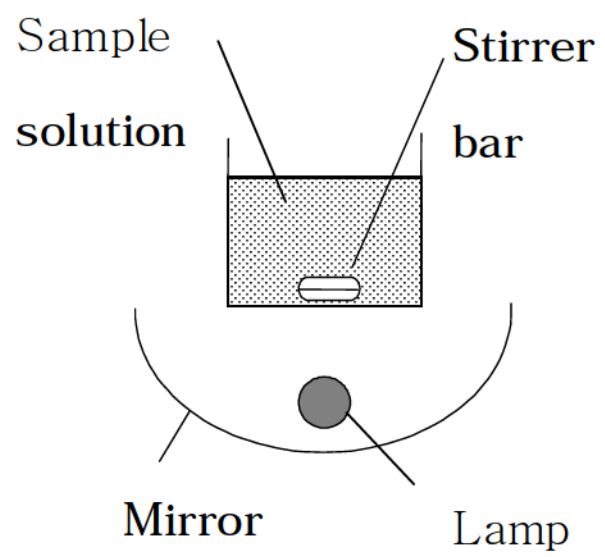

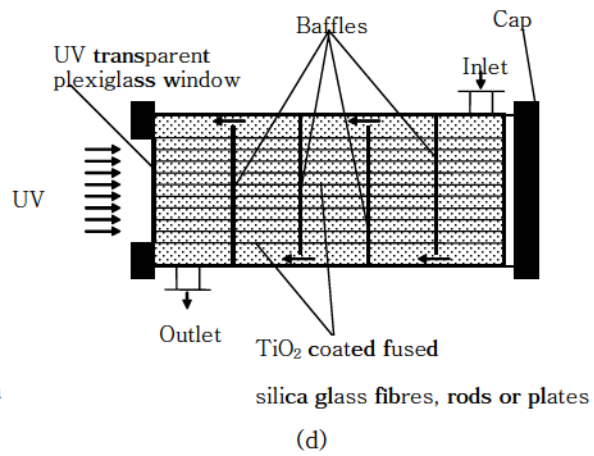
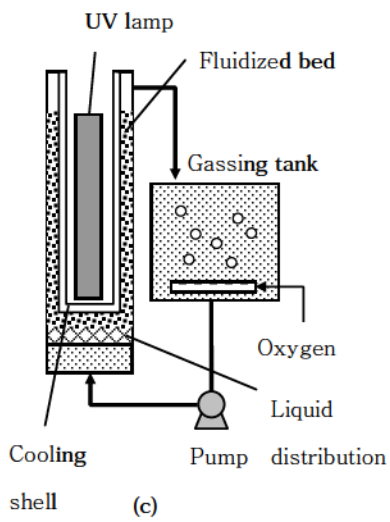
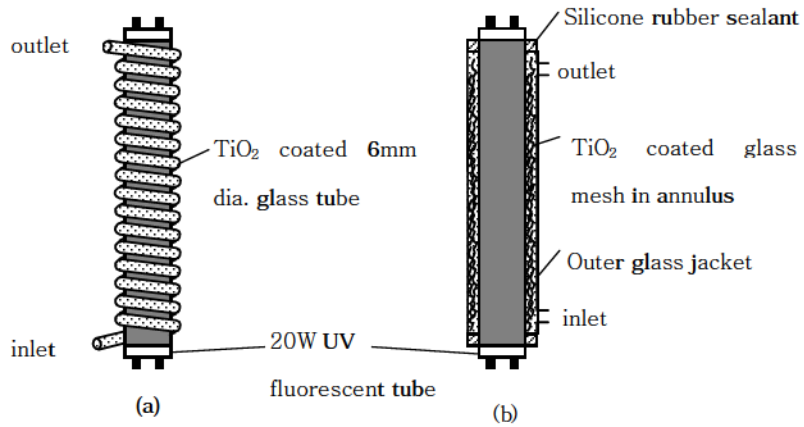

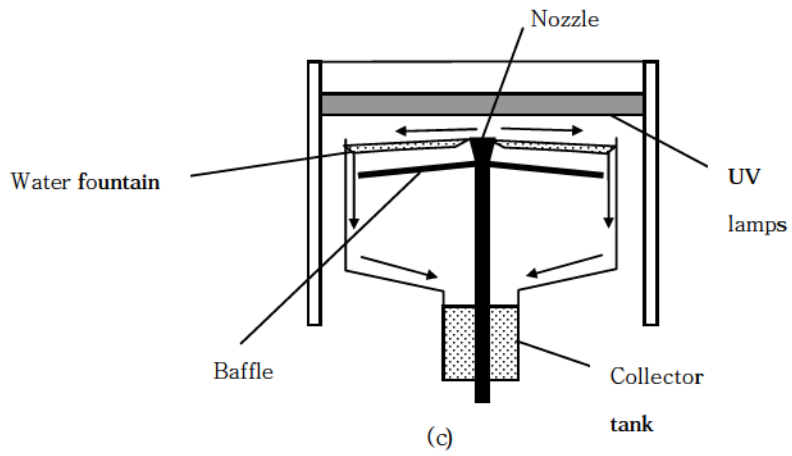
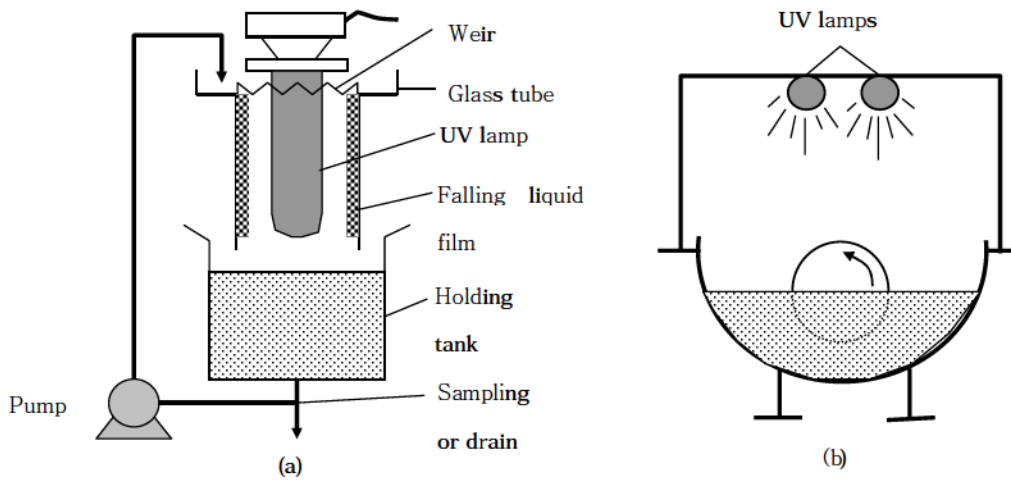

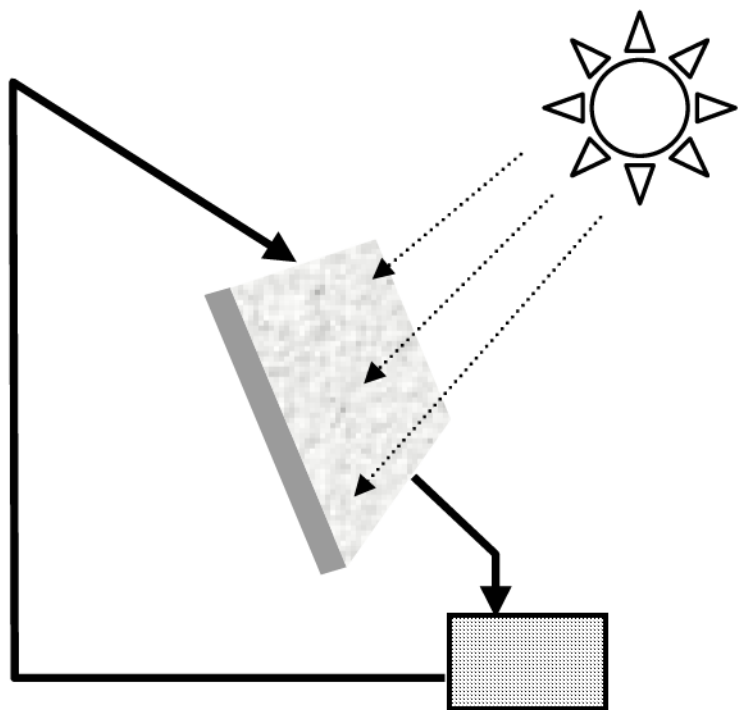

(a)

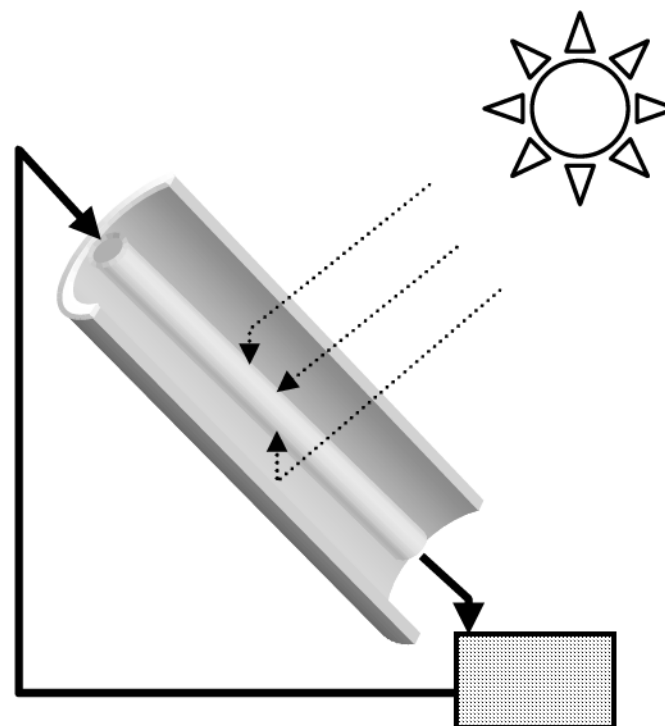

(b)

