

MIG Gas Shielding - Economic Savings Without Detriment to Quality

N.A. McPherson^a

M.J. MacPherson

BAE Systems Surface Ships
Glasgow, UK

norrie.mcpherson@baesystems.com

A.M. Galloway^b

A. Gillies

S.W. Campbell

T. Scanlon

A. Moir

Department of Mechanical &
Aerospace Engineering
University of Strathclyde
Glasgow, UK

alex.galloway@strath.ac.uk

A.J. Moore^c

T. Wu

Department of Mechanical
Engineering
Heriot-Watt University
Edinburgh, UK

a.moore@hw.ac.uk

Abstract—Over the years a number of claims have been made related to potential savings of the shielding gas used in the MIG process.

A number of work streams have been set up to consider such areas from a technical and economic standpoint. The use of small helium additions has particular benefits and despite an increase in unit cost, the overriding benefits are achieved in reduced man-hour cost. A similar situation has been established when using a high frequency process to switch shielding gases during welding. The outcome from this was very similar to that already described.

Overlaid on these has been the increasing use of a technique that visualises actual gas flow during welding by the use of laser backlighting. Some preliminary work in this area is described particularly related to the effect of drafts on the gas distribution.

A recent development on the market place is a piece of equipment, which regulates the gas flow automatically and synchronously with the welding current. Gas savings in the region of 50-60% have been obtained. Data has been produced to illustrate these benefits.

The potential benefit of developing a computational fluid dynamic model of the gas flow is also described, and early development stages of the model shown.

However, there will always exist the very basic management need to minimise leaks from the gas delivery systems.

Keywords—alternating shielding gases; artificial neural networks; laser backlighting; distortion reduction; increased productivity; quality improvement; CFD model; shielding gas reduction; MIG welding; DH36 steel

I. INTRODUCTION

Gas shielding is a very significant component of the MIG welding process. In the European shipbuilding industry, the most common shielding gas is 80% argon / 20% carbon dioxide, whereas in other regions 100% carbon dioxide is the favoured option, mainly due to the availability of economic supplies of argon. Optimising the gas flow rate and composition for a number of conditions is a challenging issue, and the solution has been to ensure that more than enough gas is used. However, it is known that excessive shielding gas flow will result in turbulence in the weld and porosity. The main challenge has been to develop a set of criteria which allowed the optimum gas flow rate to be determined.

In addition, there has been an on-going debate as to the effect of small additions of elements such as helium to the overall efficiency of the process. This has to be reinforced by robust economic evaluations. Emerging technologies such as alternating shielding gases have been developed for aluminium but the case for it being used on steel has yet to be effectively made.

There is also the need for a comprehensive computational fluid dynamic model of the gas shielding process to, hopefully, simplify the evaluation of process alterations. Such process alteration techniques are currently being marketed which claim to offer significant savings in shielding gas consumption.

It is against this background that a number of studies have been carried out at the University of Strathclyde. In some of these studies the work has been augmented by the use of laser back lighting to visualise the gas flow in the weld region.

The main function of this work is to develop a concerted approach to maximising the benefits of automated MIG welding, and also minimise the distortion experienced in thin plate.

II. THE EFFECT OF SMALL HELIUM ADDITIONS TO 80% AR / 20% CO₂

This part of the work [1] considered three gas compositions. These are shown in Table 1. The material being welded was 4mm thick DH36 steel, which is typical of that used on naval ship superstructures.

Initial work was carried out on bead on plate weld, which was subsequently extended to butt welds, which were welded against a ceramic backing tile.

The main effects of the helium addition were that an increase in travel speed could be accommodated which in turn had the effect of reducing the heat input, as shown in Table 1.

This reduction in heat input did not translate to a uniform reduction in distortion. For that aspect of the work, the 10% helium addition appeared to give the optimum effect. There was also little difference on the plate peak temperatures for the two helium containing gases.

The physical aspects of the weld are shown in Table 1, where the effects of helium decreased the weld volume. In addition the weld metal hardness increased as the amount of helium was increased but this was not to a level that would cause any concern at all. Overall there were no detrimental effects of adding helium to the MIG shielding gas. Potential benefits were present in the form of increased speed of work and decreased potential for panel distortion.

Table 2 presents the basic components of an economic evaluation for the three gases. The key fact that comes out of this data is that actual gas cost is between 2.5% and 5% of the total cost of this part of the evaluation and does not take any account of leaks in the system etc.

Overall there are at least a 27% and a 16% cost benefit in adding 20% and 10% helium respectively to the base case shielding gas.

TABLE 1: GAS COMPOSITION AND OTHER RELEVANT FACTORS IN GASES WITH HELIUM ADDITIONS

Gas mixture	80Ar / 20CO ₂	76Ar/ 14CO ₂ / 10He	66Ar/ 14CO ₂ / 20He
Travel speed (mm/sec)	10	12	14
Heat input (kJ/mm)	0.54	0.47	0.395
Max. distortion (mm)	7.28	6.34	6.69
Weld width (mm)	11.7	9.5	7.2
Max hardness (HV ₁₀)	202	216	208

TABLE 2: ECONOMIC FEATURES

Gas mixture	80Ar / 20CO ₂	76Ar/ 14CO ₂ / 10He	66Ar/ 14CO ₂ / 20He
(all per metre)			
Welding time (secs)	100	83	71
Gas Consumption (m ³)	0.0250	0.0208	0.0178
Gas cost (£)	0.0312	0.0386	0.047
Labour cost (£)	1.25	1.0417	0.8929
Total cost (£)	1.281	1.0803	0.94
Gas cost as % of total	2.44	3.56	5

III. THE EFFECT OF USING THE ALTERNATING GAS PROCESS

The alternating shielding gas process [2-5] is a relatively new method of delivering the shielding gas to the weld area. It involves discretely supplying two different shielding gases, at a preset frequency, in order to take advantage of the beneficial properties of each gas. In doing so, this creates complex flow patterns which were caused by a dynamic action in the weld pool. It is reported [2] that this dynamic action is a consequence of three independent phenomena: arc pressure variation, variation in weld pool fluidity and arc pressure peaking. This particular area is not fully understood and will be the subject of further research by one of the authors.

Initial trails [3] of alternating shielding gases have been performed on 8mm thick DH36 steel plate, which was being welded in a butt configuration. The base case was the normal 80% argon / 20% carbon dioxide shielding gas mixture and welded according to an industry standard. The alternating gases were helium and 80% argon / 20% carbon dioxide with 1.0mm diameter metal cored wire. The effect of varying the alternating frequency between 2Hz and 8Hz was evaluated.

Comprehensive mechanical testing has been carried out to determine any effects alternating shielding gases have on the mechanical properties of the joint. Marginal increases to the tensile strength, yield strength, hardness and Charpy impact toughness have been found as a result of implementing alternating shielding gases. However, the main purpose for mechanical testing was to ensure that no detrimental effects are associated with supplying shielding gases by this method.

The main benefit of using this process was an increase in the welding speed of 15% for the second pass and 50% for the third pass. There was no difference in the speed for the root run. On the basis of this there was a reduction in heat input which was reflected in an additional economic benefit of lower distortion. Overall, distortion at the centre of the plate has been reduced by 18-38.5%, longitudinal distortion by 16-30% and transverse distortion by 11-15%.

TABLE 3: ECONOMIC EVALUATION

Gas mixture	80Ar / 20CO2	Average Alternating
(all per metre for all passes)		
Welding time (secs)	792.86	795.92
Gas Cost (£)	0.16	0.85
Wire cost (£)	2.91	2.27
Electricity cost (£)	0.17	0.12
Labour cost (£)	12.17	9.95
Total cost (£)	15.41	13.19
Percentage saving (%)		16.85

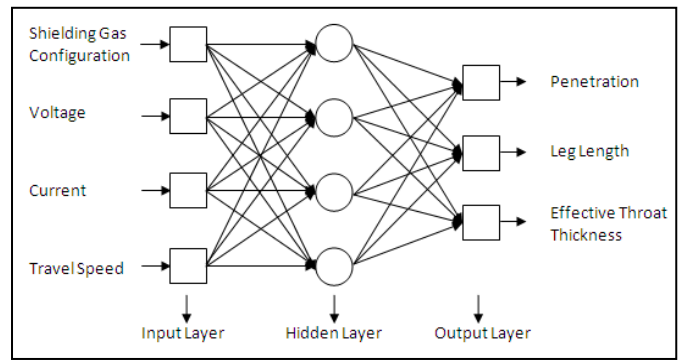

Figure 1: Multilayer Perceptron Architecture with 1 Hidden Layer

The model has been shown to accurately predict key weld features. In comparison to experimental trials, the model has been shown to overestimate weld penetration by 0.06 mm, and underestimate leg length and effective throat thickness by 0.23 mm and 0.52 mm respectively.

The model was also trained in reverse to determine the weld parameters required to satisfy a given geometry requirement. It was found that the use of alternating shielding gases allow, on average, for the travel speed to be increased by 28% whilst maintaining equivalent levels of penetration.

The model was applied to a given set of weld parameters with the only variable being shielding gas configuration. It has been shown that the use of alternating shielding gases provides an increase in penetration over conventional 80% argon / 20% carbon dioxide mixture. It was also shown that alternating gases produce a more convex weld with a shorter leg length. This was attributed to the more constricted arc column and a difference in surface tension produced by helium. In addition, the frequency of alternation has been shown to affect the level of penetration as shown in Fig. 2.

Preliminary trials [5] have also taken place on AA6082T6, and show a close similarity to the work performed on DH36 steel. Results have shown an increase in welding travel speed and tensile strength, and a reduction in distortion and porosity.

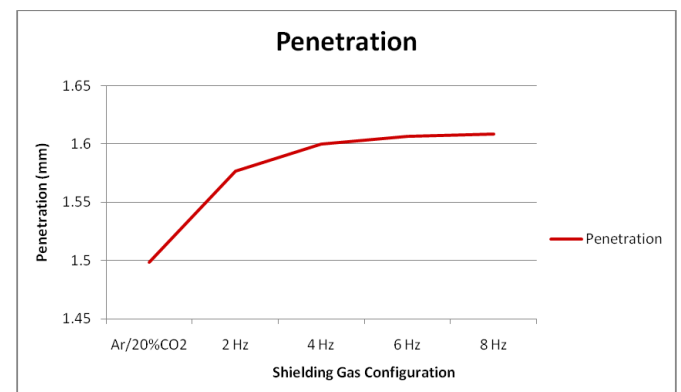

Figure 2: Effect of Shielding Gas Configuration on Predicted Penetration

As with the helium additions study, an economic evaluation was carried out for alternating shielding gases as displayed in Table 3. The economic evaluation showed that there was a 17% saving against the base case when using the alternating shielding gas process at 2Hz. This frequency was found to be the optimum level. In line with the case of the helium additions to the shielding gas case, the dominant cost factor was labour which accounted for approximately 75-80% of the total welding cost.

More recently, a study [4] with alternating shielding gases has been carried out on 6mm thick DH36 steel in an inverted ‘T’ fillet weld configuration. An artificial neural network (ANN) model was generated to determine how the gas configuration influences the penetration, leg length and effective throat thickness.

ANNs are mathematical or computational models that are able to capture and represent complex input-output relationships. Theoretically ANNs can be developed to predict any process as long as sufficient data is available to accurately train the model.

The ANN model was generated using NeuroSolutions, and it was found that the following architecture provided the best fitting results:

Model Topology	-	Multilayer Perceptron
Iterations	-	8,000
Hidden Layers	-	1
Momentum Coefficient	-	0.7
Weight Updating	-	Batch

The basic architecture of the model is depicted in Fig. 1 and consists of interconnected processing elements between the different layers of the system

IV. THE APPLICATION OF LASER BACKLIGHTING TO MIG SHIELDING GAS STUDIES

As an integral part of this area of research there has been collaborative work with Heriot-Watt University in Edinburgh. The set up was based on using a stationary welding torch and a movable work piece. This allowed a collimated beam from a 10mW helium-neon laser to illuminate the welding region at an angle of $\sim 90^\circ$ to the weld line. Once the beam was focussed, an image was formed on a high-speed camera. A narrowband (1nm) optical band pass filter centred on the laser wavelength (633nm) was placed in front of the camera detector. This allowed the laser light to be imaged in the presence of the welding arc. Camera images were recorded at 9,000 frames/second. This was a practically determined compromise to achieve a sufficiently short exposure to avoid image oversaturation whilst maintaining an adequate image resolution [256(H) x 128(V)pixels].

A number of different scenarios have been visualised. The initial work was aimed at determining gas coverage at different flow rates in still conditions. Above 10l/min, there was obvious lateral flow of the shielding gas away from the weld area.

In addition, the effect of spatter build up on the nozzle was evaluated. The effect of this was to restrict the diameter of the shielding gas, but not the observed lateral flow.

A second phase of work specifically observed the effects of cross drafts at various shielding gas flow rates. This was carried out to start to reproduce 'real' conditions, and establish under what conditions the flow could be effectively dropped to ~ 10 l/min.

A parallel cross-draft was introduced through the use of a fan, the speed of which was measured with a hot-wire anemometer in the region between the nozzle and the plate.

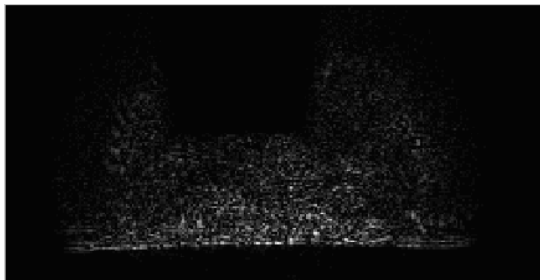

Figure 3a: Shielding gas flow 17l/min – no side draft

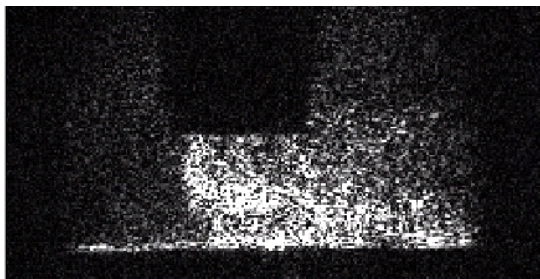

Figure 3b: Shielding gas flow 17l/min - 5mph side draft

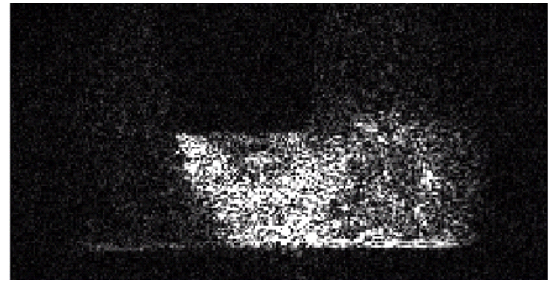

Figure 3c: Shielding gas flow 17l/min - 10mph side draft

Draft (mph)	Flow (lpm)			
	10	15	17	20
0	T10, 43	T9, 42	T4, 44	T1, 45
1	T40	T41	T47	T46
2	T39	T38	T37	T28, 36
3		T35	T34	T29
4			T33	T30, 32
5	T11	T8	T5	T2, 31
10	T12	T7	T6	T3

Figure 4: Correlation among shielding gas flow, draft speed and weld quality

Fig. 3(a) to (c) quite clearly show the effect of increasing the draft on the shielding gas distribution over the weld area. Finished welds were examined visually, graded and then subjected to internal inspection via radiography. The visual examination was found not to be critical enough and therefore any results quoted are based on the radiographic interpretation.

The data shown in Fig. 4 shows draft speed (mph) against shielding gas flow rate (l/min). The green areas represent combinations where the weld metal quality was acceptable, the yellow areas represent welds which showed acceptable and non-acceptable results and the red was indicative of unacceptable quality.

The critical ratio of shielding gas flow rate to draft speed is approximately 10. If it is assumed that the flow is incompressible, the corresponding shield gas speed to draft speed ratio is 0.6. This is lower than the data of Tamaki et al [6] who reported a value of 1.6-2.1 for this ratio. It is difficult to compare the two sets of results as factors such as gas composition and nozzle design had to be taken into account. The Japanese work was based on CO₂ welding.

V. DEVELOPMENT OF A CFD MODEL OF MIG GAS SHIELDING

Much of the preceding work has been aimed at developing enough data to feed into the CFD model development.

Gambit is the geometry and mesh generation software for the CFD solver Fluent. This is based on a bottom up principle, with the vertices being created first then the edges and faces before the volumes are created. The weld nozzle geometry with an approximate arc is shown in Fig. 5.

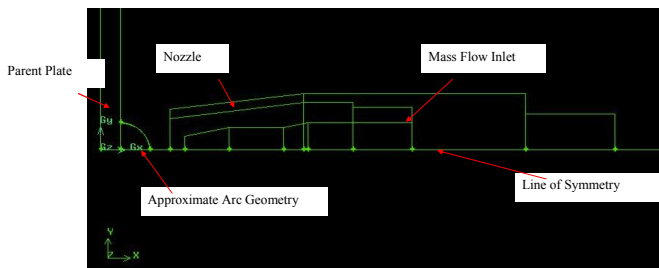

Figure 5: Weld nozzle geometry

This is a half model of the weld nozzle with a line of symmetry running along the X-axis. The half symmetry model significantly reduces the computing requirements and is more efficient than running a full volume model. For this case the plate modelled was 4mm thick steel. The mesh generated along the bottom surface within the control volume is shown in Fig. 6.

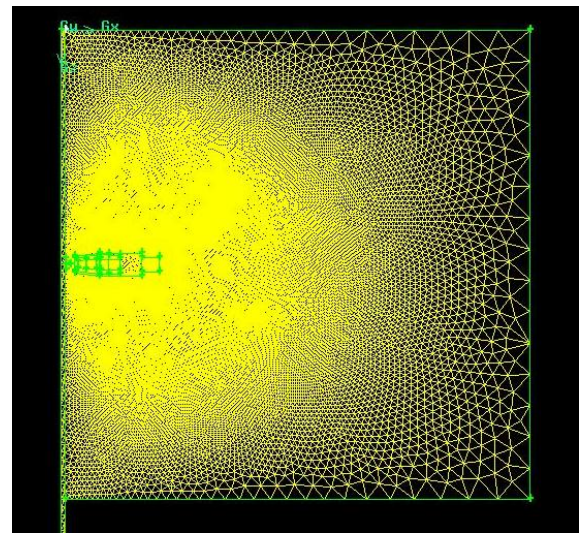

Figure 6: Mesh detail around nozzle

As can be seen the intensity of the mesh has been increased in the area of interest at the exit of the nozzle. This is particularly important as it is in this area that the flow will be in its most turbulent state and requires detailed analysis. Other areas of interest were also more finely meshed. This is a particularly challenging simulation due to the need to accurately simulate the fluid flow in the vicinity of the arc. To achieve this, the arc was represented as an energy source, which by its nature neglected the arc efficiency, the electrical fields and the magnetic fields. However it was still sufficiently accurate to supply the heat required to model the physical fluid flow in the area of interest. The arc was modelled as a quarter sphere and the value of the energy source was increased gradually until a core temperature of the arc reached an expected level of around 3000°C.

Fluent was used for the processing and post processing of the CFD models created in Gambit. Various parameters need to be defined before the model can be solved. Once these have been defined the model can be solved to a level of satisfactory convergence. This specific stage of the modelling was used to model nitrogen absorption by a stainless steel weld metal.

Fig. 7 shows the velocity of the gas as it is accelerated from the inlet to a maximum velocity of 4.15m/sec at the outlet of the nozzle. This shows the steady state model. When the transient analysis was carried out the velocity contour was very similar.

This model is still under development and the intention is to use much of the work already carried out to calibrate it. This will include the work on laser backlighting which is particularly critical to the validity of the model.

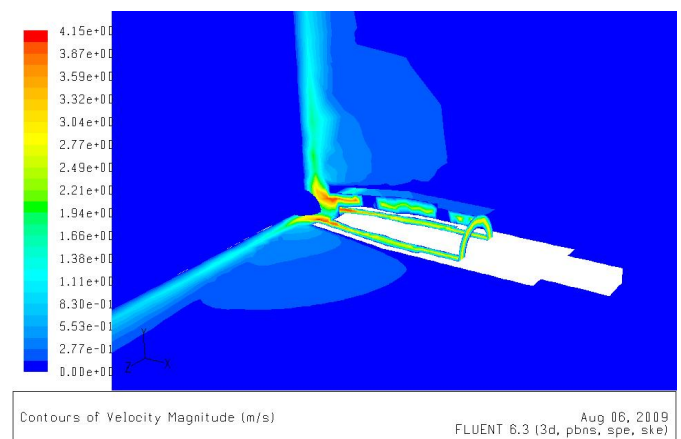

Figure 7: Gas velocity profiles for steady state model

VI. COMMERCIALLY AVAILABLE GAS USAGE REDUCTION SYSTEMS

A number of these systems are currently on the market and make claims to save about 50% of the shielding gas usage. All of them have surge suppressing, where the initial gas surge is eliminated. However, others also seem to be capable of generating further benefits, via a linkage to the welding current. This is currently the focus of attention within BAE Surface Ships to develop an understanding of what the critical factors are in its operation. There does appear to be a pulsing effect which is perhaps creating the same weld conditions that were seen in the alternating shielding gas work.

As a comparison the flow control valve reduced the gas usage from 127.29 litres to 51litres, using similar pressures. This was a very small scale trial and the overall quality appeared to be acceptable.

VII. CONCLUDING COMMENTS

The contents of this paper have demonstrated that there is significant scope to reduce the cost factor of shielding gas usage within the MIG welding process. This is accomplished without any detriment to quality and in some cases with benefits such as reduction in distortion.

The establishment of a CFD model will greatly aid future work in this area.

However, even with this level of technology in place, the very basic issues about leaks from gas supply lines being resolved would create additional benefits.

ACKNOWLEDGMENTS

The authors wish to thank their relevant institutions for permission to publish this paper.

In addition, the authors would like to acknowledge the funding provided by the Scottish Association for Metals, Lincoln Electric, NST and Abicor Binzel.

REFERENCES

- [1] A. Gillies, A. M. Galloway, and N. A. McPherson, "Helium additions to MIG shielding gas - an economic option?" in *Welding and Cutting*, Vol.10, No.2, 2011, 118-121.
- [2] Y. H. Chang, "Improve GMAW and GTAW with alternating shield gases" in *Welding Journal*, Vol.85, No.2, 2006, 41-43.
- [3] S. W. Campbell, A. M. Galloway and N. A. McPherson, "Techno-economic evaluation of alternating shielding gases for advanced joining processes" in *Proceedings of IMechE Part B: Journal of Engineering Manufacture*, in press.
- [4] S. W. Campbell, A. M. Galloway and N. A. McPherson, "Artificial neural network prediction of weld geometry performed using GMAW with alternating shielding gases", unpublished.
- [5] S. W. Campbell, A. M. Galloway and N. A. McPherson, "Evaluation of gas metal arc welding with alternating shielding gases for use on AA6082T6", unpublished.
- [6] K. Tamaki, I. Masumoto and Y. Takahashi, "Some observation on the gas shielding conditions of CO₂ arc welding by the application of a television system" in *Journal of the Japan Welding Society*, Vol.47, No.5, 1978, 37-42.