

Gross plastic deformation of axisymmetric pressure vessel heads

Duncan Camilleri*, Robert Hamilton and Donald Mackenzie

Department of Mechanical Engineering, University of Strathclyde, 75 Montrose Street, Glasgow, Scotland, UK

Abstract: The gross plastic deformation and associated plastic loads of four axisymmetric torispherical pressure vessels is determined by two criteria of plastic collapse: the ASME Twice Elastic Slope TES criterion and the recently proposed Plastic Work Curvature PWC criterion. Finite element analysis was performed assuming small and large deformation theory and elastic-perfectly plastic and bilinear kinematic hardening material models. Two plastic collapse modes are identified: bending dominated plastic collapse of the knuckle region, in small deformation models and membrane dominated plastic collapse of the cylinder or domed end, in large deformation models. In both circumstances, the PWC criterion indicates that a plastic hinge bending mechanism leads to gross plastic deformation and is used as a parameter to identify the respective plastic loads. The results of the analyses also show that the PWC criterion leads to higher design loads for strain hardening structures than the TES criterion, as the criterion takes account of the effect of strain hardening on the evolution of the gross plastic deformation mechanism.

* Corresponding author: Department of Mechanical Engineering, University of Strathclyde, James Weir Building, 75 Montrose Street, Glasgow G1 1XJ; Email: d.camilleri@strath.ac.uk, Fax: +44 (0) 141 552 5105

Keywords: Gross plastic deformation, plastic load, criterion of plastic collapse, axisymmetric torispherical pressure vessel heads, inelastic finite element analysis.

Notation:

D	Cylindrical outer diameter (m)
L	Modelled length of cylinder (m)
L_c	Conical transition length (m)
P_ϕ	Plastic load – TES criterion
R	Circumradius of a triangle (m)
R_s	Sphere radius (m)
r	Knuckle radius (m)
S	Semiperimeter of a triangle (m)
S_m	Design stress (MN/m ²)
t	Sphere thickness (m)
t_c	Cylinder thickness (m)
ϕ	Semi-angle of spherical portion (°)
λ	Load parameter
λ_p	Plastic load – PW criterion
σ_y	Yield strength (MN/m ²)

1. INTRODUCTION

Gross Plastic Deformation, GPD, is the basic static failure mechanism considered in Design by Analysis, DBA, of ductile pressure vessels. The wall thickness of the vessel must be great enough to ensure that GPD does not occur under the specified

mechanical design loads. This is most commonly achieved through linear elastic stress analysis of the design configuration followed by application of a stress classification procedure defined in Codes and Standards such as PD5500 *Unfired fusion welded pressure vessels* [1], ASME *Boiler & Pressure Vessel Code* Sections III and VIII [2] and EN 13445-3:2002 *Unfired pressure vessels* [3]. In design, GPD is prevented by limiting the allowable primary stress calculated in the elastic analysis. The definition of primary stress and specified allowable loads are determined through elastic analysis according to the principles of limit analysis [4]. Alternatively, the allowable load may be calculated by performing an actual (inelastic) limit analysis of the vessel and restricting the design load to a fraction of the limit load, following procedures given in references [1, 2, 3]. Both of these approaches assume that the vessel material is ductile and is represented by a rigid-perfectly plastic or elastic-perfectly plastic material model. The effect of strain hardening on the load carrying capacity of the vessel is not included in either elastic or limit analysis, although it is considered in the specification of design stress in [1] and [2], and through a partial safety factor in reference [3], as discussed in reference [5]. The ASME Code provides a design route based on elastic-plastic analysis which may include a strain hardening material model, through which the design load is restricted to a fraction of the specified “plastic” load. The plastic load is found by applying a *criterion of plastic collapse* to a characteristic load-deformation curve for the vessel obtained from elastic-plastic analysis.

The ASME Twice Elastic Slope (TES), criterion is based on an empirical procedure for calculating collapse loads in experimental stress analysis of pressure vessels and is illustrated in Figure 1. The plastic load, P_{ϕ} is the load corresponding to the

intersection of the load-deformation curve and a straight line called the *collapse limit line*, emanating from the origin of the load-deformation curve at angle $\varphi = \tan^{-1}(2 \tan \theta)$. Several problems associated with the TES criterion have been identified in the literature [6, 7, 8, 9, 10]. In some cases the load-deformation curve and collapse limit line do not intersect, due to loss of equilibrium. When intersection does occur, the value of plastic load is highly dependent on the load and deformation parameters used in the design assessment, a consequence of using a local deformation parameter to characterise the global inelastic response of the vessel. The calculated plastic pressure is also influenced by the elastic response of the structure remote from the region where the plastic failure mechanism actually occurs. This has particular implications for design based on FEA, as analysts often minimise computing requirements by modelling only specific sections of the vessel, not the whole. Further, the TES criterion does not fully account for the effect material strain hardening has on the load carrying capacity of the vessel and plastic loads calculated using the criterion tend to be close to the theoretical limit load.

The conservative nature of the TES criterion, which essentially incorporates strain hardening strength enhancement as an additional unknown factor of safety, is appropriate when better analysis methods are not available. However, it is now routinely possible to perform detailed strain hardening elastic-plastic analysis of most pressure vessels on modest desktop computers, using user-friendly finite element analysis software. This advanced analysis approach should allow the designer to better quantify the margin of safety against GPD, however application of collapse criteria negate the advantage of performing such analysis. This has led the writers and others [11] to revisit the concept of plastic collapse criterion, extending ideas relating

plastic collapse to plastic dissipation in the vessel proposed by Gerdeen in [6]. Gerdeen proposed that the relationship between the formation of the plastic failure mechanisms and the plastic work dissipated in the vessel could provide a rational basis for a plastic collapse criterion. Muscat *et al* [12] later proposed a plastic collapse criterion based on a characteristic plot of a global load parameter, λ , representing all applied loads, against plastic work dissipation in the vessel, as illustrated in Figure 2a. The initial response of the structure is elastic until the yield occurs and the plastic deformation mechanism begins to form. As the load is increased, part of the external work done is stored as elastic strain energy and part is dissipated as plastic work. The characteristic load-plastic work curve has a non-linear form between elastic-dominated and plastic-dominated response. Once the plastic deformation mechanism has formed, the structural response characterised by the load-plastic work curve becomes almost a straight line. At this stage, the vessel experiences GPD. The safe plastic load for design purposes must, therefore, lie somewhere between yield and the steady plastic deformation response.

In the PW criterion, illustrated in Figure 2b, a conservative plastic load λ_p is defined by taking a tangent from the steady plastic deformation portion of the characteristic curve to the load parameter axis. The criterion essentially replaces the actual elastic-plastic response curve with an ideal curve in which the behaviour is elastic up to the Plastic load λ_p and thereafter exhibits a linear GPD response, as illustrated in Figure 2c. This is a reasonable design approximation, in principle similar to others reviewed by Gerdeen [6]. The PW criterion has the practical advantage that it is simple to apply in practice and dispenses with some of the problems that may be encountered when using the TES criterion. However, it requires that the steady GPD response line is

applied at the appropriate point on the characteristic curve, and the rationale for this choice is perhaps subjective.

The plastic work criterion approach as proposed offers practical advantages in design. The method also incorporates a model of elastic plastic response, purely elastic changing to GPD at the plastic load, that provides some justification for the specified plastic load. However, this justification is crude and does not account for the physical processes that actually occur as the behaviour changes from elastic to grossly plastic. A more detailed investigation of the transition from elastic to gross plastic response has recently been presented by Li & Mackenzie [13, 14]. They proposed an interpretation of the load-plastic work characteristic curve that directly relates the formation of the gross plastic deformation mechanism to the curvature of the characteristic load-plastic work curve.

When a strain hardening structure is loaded beyond yield, the stress distribution changes from elastic to elastic-plastic. As the load increases, further stress redistribution occurs as the plastic strain spreads through the thickness of the vessel. Stress redistribution continues with increasing load until a stable or constant elastic-plastic stress *distribution* is achieved and no further stress redistribution occurs with increasing load. This is analogous to the limit state when the material is elastic-perfectly plastic. The work done on the structure after the plastic mechanism forms must be either stored as strain energy in the elastic regions of the vessel or be dissipated through gross plastic straining of the established plastic regions (unless a new plastic deformation mechanism forms in the previously elastic region). In effect, any increase in load causes the magnitude, but not the distribution, of plastic strain to

change. The vessel therefore experiences gross plastic deformation and the corresponding pressure is the gross plastic deformation pressure, P_{GPD} , of the vessel.

This response can be identified by considering the curvature of the characteristic load-plastic work curve, as illustrated in Figure 3. The curvature of the plot characterizes how plastic stress redistribution occurs as the load is increased. In the elastic region, the curvature is zero. Post yield, plastic stress redistribution occurs and the Plastic Work Curvature, PWC, increases to a maximum as the plastic deformation mechanism develops. The maximum stress redistribution occurs at the load corresponding to the maximum PWC, where after it begins to decrease as the plastic deformation mechanism is established. When the PWC reaches a minimum constant or zero value, relatively little or no further plastic stress redistribution occurs in the vessel unless a second plastic deformation mechanism is initiated in a formerly elastic region. At this stage the structure exhibits constant or gross plastic deformation and, in the PWC criterion, the corresponding load is designated the plastic load for DBA.

In this paper, the PWC criterion is used to investigate the elastic-plastic behaviour of four torispherical pressure vessel heads. Torispherical ends are known to experience complex plastic deformation prior to failure, with the formation of plastic-hinge bending mechanisms in the knuckle and membrane plastic deformation in the crown and cylinder. The aim of the investigation is to establish if the PWC criterion adequately represents these complex deformations and is an appropriate method for calculating plastic pressures.

2. ANALYSIS OF TORISPHERICAL VESSELS

In this paper, the PWC criterion is applied to four thick or intermediate thickness

torispherical end configurations that have previously been considered in the literature. The geometry and dimensions of the heads investigated are defined in Figure 4 and Table 1 respectively. Head 1 [15] is welded to a cylindrical vessel (of equal thickness) and has a cylindrical diameter to dome thickness ratio $D/t=29$. The vessel includes a conical transition region between the knuckle and the spherical dome, as shown in Figure 4a. Head 2 [16] has cylinder diameter to spherical dome thickness ratio $D/t=34$. The head is attached to a rigid flange, as illustrated in Figure 4b. Head 3 [17] has a cylindrical diameter to dome thickness ratio $D/t=162.6$ and is attached to a thinner cylinder, as shown in Figure 4c. Head 4 [18] has cylindrical diameter to dome thickness ratio $D/t=300$. The head is attached to length of cylindrical vessel which terminates at a rigid flange, as illustrated in Figure 4d.

Limit analysis and plastic analysis were performed using elastic-perfectly plastic and bilinear material properties, respectively. The values of yield stress and Young's modulus used in elastic-perfectly plastic analysis of Heads 1 to 4 are as specified in references [15] to [18] and are given in Table 2. These values were used for large and small deformation theory elastic-perfectly plastic analysis.

The bilinear material parameters for all four heads (yield stress, Young's modulus and plastic modulus) are given in Table 3. The bilinear hardening curves used in the analysis of Head 1 and Head 3 were obtained from the values of yield stress and tensile stress (and associated strains) defined in references [15] and [17]. For comparison with the results presented in reference [15], the yield stress used in the elastic-perfectly plastic analysis presented here for Head 1 is $\sigma_y = 1.5S_m$, where $S_m=184 \text{ MN/m}^2$. However, reference [15] also defines a multilinear hardening stress-

strain model based on stress-strain data for use in plastic analysis. This data indicates a value of yield stress considerably greater than $1.5S_m$ (276 MN/m^2), specifically 370 MN/m^2 . To allow direct comparison with the plastic analysis results presented in [15], this higher value of yield was used in the plastic analysis bilinear hardening model for Head 1. Insufficient data was given in References [16] and [18] to determine a plastic modulus for Heads 2 and 4. In this study, the elasto-plastic material data of austenitic steel, X2CrNiN810, given in reference [17] was used to establish a plastic modulus of 1 GN/m^2 , for Heads 2, 3 and 4.

3 Finite Element Modelling

Finite element analysis was performed using the ANSYS program [19]. Small and large deformation theory analyses were performed for elastic-perfectly plastic and bilinear hardening material models, such that four different types of analysis were performed for each head. The heads were modelled using 2D 8 node axisymmetric elements, plane82. The heads were meshed with 8 elements through thickness for Heads 1 and 2 and 6 elements through thickness for Heads 3 and 4. The nominal element aspect ratio was limited to 1.5. A typical finite element mesh, for Head 1, is shown in Figure 5.

Head 1 and Head 3 models had symmetry boundary conditions applied to the end of the cylindrical section of vessel. The rigid flange connected to Head 2 was modelled as a fully fixed boundary at the end of the knuckle section. The rigid flange terminating the cylindrical section of Head 4 was also modelled as a fully fixed boundary. Internal pressure loading was applied to the models in small load increments and the results stored for each increment.

4 Results

The structural response of the vessel was investigated in three ways: graphical representation of the evolution of the gross plastic deformation in terms of equivalent plastic strain contour plots, TES criterion load-deformation plots and PWC criterion load-PWC plots. Two deformation parameters were used in the TES criterion for all the Heads: the radial displacement at the middle of the knuckle and the vertical displacement at the crown. In addition, the radial displacement of the Head 3 cylinder (at the symmetry end) was investigated for comparison with published results.

The PWC criterion requires a plot of load against normalised load-plastic work curvature. The load-PWC plot may be created from the numerical results of the FE analysis using any suitable external plotting and graphing program. In references [13] and [14], spline fitting was applied to the FE data using the commercial program ProE to generate normalised PWC plots superimposed on the load-plastic work curve, as shown in Figure 3. Here, the normalised PWC is plotted against applied pressure using a simple technique based on the circumradius of three points [20]. The plastic work corresponding to the applied load is calculated by the FE program for each load step. These results are written to a data file as a series of load-plastic work points. The curvature of a sector of curve defined by three consecutive points is the inverse of the circumradius of the three points. The circumradius R of a triangle of sides length a , b and c , as shown in Figure 6a, is given by:

$$R = \frac{abc}{4\sqrt{s(a+b-s)(a+c-s)(b+c-s)}} \quad (1)$$

where s is the semiperimeter given by:

$$s = \frac{a+b+c}{2} \quad (2)$$

The accuracy of the results depends on the number of load steps used and results saved in the analysis. Excessively large load steps between adjacent points could lead to inaccurate interpretation of the curvature. Figure 6b shows a plot of PWC against load created using the circumradius method. In the plot, the PWC is normalised with respect to the *maximum* value of PWC calculated in the analysis.

4.1 Head 1

Plastic deformation of Head 1 initiates at the inside surface of the knuckle. In the small deformation elastic-perfectly plastic analyses, first yield occurs at 7.2 MN/m². A second plastic zone initiates at the outside surface of the cone-sphere intersection at 18 MN/m². Both plastic zones continue to develop through the thickness of the pressure vessel with increasing load. A third highly localised, plastic zone also occurs at the outside surface of the cylindrical region at 21.3 MN/m², just prior to limit collapse. The third zone does not significantly affect the collapse mechanism, which is essentially a 2 plastic hinge bending mechanism at the limit load of 21.6 MN/m².

The load-plastic work plot for Head 1 large deformation elastic-perfectly plastic analysis is shown in Figure 7a. In the large deformation elastic-perfectly plastic analyses, first yield occurs at 7.5 MN/m², and is followed by formation of plastic zones corresponding to the small deformation analysis at pressures 18.6 MN/m² and 22.2 MN/m². A fourth plastic zone then occurs at the symmetry-plane end of the cylindrical vessel at 22.5 MN/m², giving rise to membrane GPD in the cylinder and instability collapse at 23.0 MN/m². It is unclear from stress plots whether the collapse

mechanism is a bending mechanism similar to that in the small deformation analysis or membrane GPD of the cylindrical shell.

The value of yield stress used in the Head 1 bilinear strain hardening analysis was the test value specified in Reference [15], which is higher than the $1.5S_m$ value used in the perfectly plastic analysis. First yield therefore occurs at the same location as in the perfectly plastic analyses but at higher pressure. In the small deformation bilinear hardening analysis, first yield occurs at 9.5 MN/m^2 . In large deformation analysis, yield occurs at 10.0 MN/m^2 . The load-plastic work plot for Head 1 large deformation bilinear hardening analysis is shown in Figure 7b. The formation of post-yield plastic zones is similar to that found in the corresponding elastic-perfectly analyses but at higher load levels. The strain hardening analyses continue to converge until almost the entire vessel experiences plastic deformation, although membrane-type plastic deformation is less evident for small deformation analysis. The plastic load is defined by applying the TES and PWC criteria of plastic collapse.

Figures 8a and 8b show load-PWC plots for Head 1 large deformation analysis with elastic-perfectly plastic and bilinear hardening material models respectively. The figures include contour plots showing the plastic zones in the vessel at salient loading points: the black areas represent elastic regions and the grey areas the plastic zones. In the elastic-perfectly plastic analysis, Figure 8a, the PWC reduces rapidly from the maximum value to zero at the instability load of the vessel. In the strain hardening model, the PWC reduces rapidly from the maximum to relatively small value but the decrease to zero is over a large load range. It is therefore necessary to specify a finite magnitude of normalised PWC that indicates gross plastic deformation. Examination

of plastic strain contour plots at different load levels as the curvature decreases from its maximum to zero indicated that when the PWC reduces to 10% of its maximum value the vessel is essentially exhibiting gross plastic deformation. The maximum principal strain at the corresponding load is 3.2%. Applying this procedure to the four analyses of Head 1, the plastic pressures given in Table 4 were obtained. Table 4 also includes a value of plastic pressure taken from reference [15], in which several commercial finite element programs were used in a “round-robin” estimate of plastic load using the TES criteria. The value given in Table 4 is an average for each type of analysis considered.

4.2 Head 2

In Head 2, the edge of the head is fixed and initial yielding occurs at the outside surface of the fixed end of the knuckle at 11.1 MN/m² and 11.2 MN/m² for small and large deformation analysis respectively. In all the analyses, plastic zones form at the location of initial yield, the inside surface at mid-section of the knuckle and the outer surface of the sphere-knuckle intersection, resulting in a three plastic hinge bending mechanism. A fourth plastic zone also initiates at the crown of the sphere in all of the analyses. The relative degree of stress redistribution in the four plastic zones with further increase in pressure, measured in terms of plastic work dissipation, is dependant on the deformation theory used in the analysis. In small deformation elastic perfectly plastic analysis, the maximum plastic deformation is observed at the fixed end until the analysis fails to converge at 22.2 MN/m². However, in the corresponding large deformation analysis, membrane plastic deformation at the fourth (crown) plastic zone becomes dominant until loss of equilibrium is observed at 27.4 MN/m². Similar stress redistributions are observed when using strain hardening

models, but as the analysis continues to converge above the perfectly plastic limit/instability loads the influence of the membrane deformation of the crown becomes more significant.

The form of the PWC plot for Head 2 to is similar to that for Head 1. The plastic loads calculated by the TES and PWC criteria, assuming the plastic load corresponds to a reduction in PWC to 10% of the maximum value, are given in Table 5. The plastic loads for perfectly plastic material and small deformation bilinear hardening are similar. However, the PWC criterion indicates a relatively high value of plastic load for large deformation strain hardening analysis. In this case the dominant GPD mechanism was the three hinge bending mechanism, with a maximum principal strain of 4.8% at the specified plastic load.

4.3 Head 3

In Head 3, first yield occurs at the knuckle region and continues to develop through the thickness. Smaller less evident, plastic zones subsequently form at the outside surface of the sphere-knuckle intersection and at the cylinder-knuckle intersection, giving rise to a plastic hinge bending mechanism. In all but the limit analysis, a fourth plastic zone forms in the cylindrical shell adjacent to the symmetry plane and two distinct slopes are observed in the load-plastic work plot.

In the small deformation analyses, the PWC plots are dominated by a peak associated with plastic deformation of the knuckle. In the bilinear hardening, a second smaller peak is observed when plastic deformation of the cylinder occurs. The PWC plastic load for these analyse was assumed to be the load at 10% of the maximum stress

redistribution. The PWC plots for the large deformation analyses are dominated by a peak associated with plastic deformation of the cylinder after the knuckle mechanism has formed. Figure 9a shows the load-plastic work plot for the large deformation elastic-perfectly plastic analysis. The first slope describes stress redistribution in the knuckle region and the second in the cylindrical region. The corresponding PWC plot, Figure 9b, has two regions indicating changes in curvature, or stress redistribution. The first, relatively small, flat plateau in the plot indicates stress redistribution in the knuckle, the second, dominant, peak indicates rapid stress redistribution in the cylinder. The PWC plot for the large deformation, strain hardening analysis has a similar form. This response clearly indicates that two plastic deformation mechanisms occur sequentially. The problem is to determine which mechanism constitutes gross plastic collapse of the structure.

From the definition of gross plastic collapse proposed in the PWC criterion, the plastic load corresponds to the reduction from a local maximum PWC in the first, knuckle, mechanism to a near-zero value. In practice, the knuckle exhibits large deformations but the geometric strengthening effect causes the actual plastic collapse mechanism to occur in the cylinder, as indicated by the second peak. However, this second mechanism would not generally be considered as the basis for design in practice and the gross plastic deformation load would usually be determined in relation to the first, knuckle, mechanism. The PWC plastic loads are therefore defined with respect to the first peak (or plateau). Both the perfectly plastic and bilinear hardening model plots fall to a minimum after the plateau before a rapid increase in PWC as the cylinder plastic deformation initiates. Here, the plastic load is taken to be that corresponding to this minimum value of PWC.

The TES and PWC criteria limit and plastic loads for Head 3 are given in Table 6. For the TES criterion, significantly different plastic loads are obtained when using different deformation parameters, as seen in Figure 10. In reference [17], Sanal applied the TES criterion to a large deformation multi-linear hardening analysis and defined the deformation parameter as radial deflection of the cylindrical shell. However, when this deformation parameter is used in small deformation elastic perfectly plastic analysis no intersection occurs between the load-deformation curve and collapse limit line. Crown and knuckle deflection deformation parameters give intersecting collapse limit lines for this type of analysis but plastic loads for other types of analysis calculated using these parameters are significantly lower than that given by the cylinder deflection parameter.

4.4 Head 4

The pressure-plastic work curves for the Head 4 small deformation perfectly plastic analyses are shown in Figure 11a. First yield occurs in the knuckle region and spreads through-thickness and in the meridional direction. Smaller plastic zones subsequently develop at the outer surface of the sphere-knuckle intersection and at the cylinder-knuckle intersection regions. In small deformation analysis, limit collapse occurs by a bending hinge mechanism at a pressure of 1.20 MN/m^2 . In the large deformation analysis, the bending hinge mechanism forms but the instability failure, at pressure 2.38 MN/m^2 , is associated with extensive membrane plastic deformation of the spherical dome.

The PWC plots for the elastic-perfectly plastic analyses are shown in Figure 11b. In

small deformation analysis, a single peak occurs corresponding to the limit collapse mechanism that forms in the knuckle. In the large deformation analysis two peaks are observed. The changes in curvature around the first peak correspond to the formation of the knuckle three plastic hinge bending mechanism. The second peak is associated with membrane plastic deformation of the crown of the head. The vessel experiences GPD once the bending hinge mechanism forms, prior to instability failure. Applying the condition that gross plastic deformation is indicated when the PWC criterion gives a PWC value of 10% of the maximum, the plastic load calculated by the criterion is significantly lower than the instability pressure, at pressure 1.79 MN/m^2 .

In the small deformation strain hardening analysis, the three plastic hinge bending mechanism forms at the knuckle as in the perfectly plastic analysis. This is characterised by the changes in curvature associated with the first peak in the load-PWC plot of Figure 12b. However, two additional plastic zones subsequently occur in the crown and in the cylindrical shell, represented by the second and (dominant) third peaks in Figure 12b respectively. The rapid changes in curvature (sharp spikes in the plot) associated with these latter mechanisms indicate that the deformation is predominantly membrane in these regions. Although these spikes dominate the curve, the critical peak in the PWC criterion is the first peak, around which the knuckle gross plastic deformation mechanism forms. In this case, the PWC does not fall to 10% of the first peak value before the second peak starts to form. The plastic load in this case is defined as that corresponding to the minimum value of PWC between peaks 1 and 2, pressure 1.56 MN/m^2 .

In the large deformation strain hardening analysis, the dominant peak is the third,

which obscures the other peaks on the normalising the PWC curve, Figure 12b. On the scale used, the first “peak” is an almost indistinguishable plateau between pressure values of 1 and 2 MN/m². This represents formation of a plastic zone in the knuckle. The second peak is associated with plastic deformation of the spherical crown. The dominant third peak is associated with stress redistribution spreading from the knuckle into the cylinder. The small fourth peak is associated with the geometric change of the head from a torisphere to gross plastic deformation of a spherical pressure vessel. At a slightly higher pressure load of 3.97 MN/m², the analysis fails to converge.

A second PWC plot of the first mechanism only is shown in Figure 13, normalised with respect to the local maximum value. As the load increases above the maximum PWC value, the curve falls sharply but does not reach zero before the second mechanism starts to form. In this case the plastic pressure is taken to be the minimum value at this location, 1.84 MN/m². The results for Head 4 are summarised in Table 7.

5. Discussion & Conclusions

The PWC criterion relates the formation of the gross plastic deformation mechanism to the curvature of the load-plastic work relationship. The torispherical head examples considered show that the load-PWC plot used in the criterion can have different levels of complexity depending on the configuration considered and type of analysis employed.

The thicker heads, Heads 1 and 2, have a relatively simple form of load-plastic work curvature plot, with a single peak in the curve indicating the formation of the gross

plastic deformation mechanism. On previous investigations of the PWC criterion [13, 14], it was proposed that the plastic load was indicated when the PWC decreased to zero or a small approximately constant value. In the thick heads, the PWC initially decreased rapidly from the maximum but the eventual decrease to a zero or near zero exhibited a long decay. It was therefore proposed that the PWC criterion plastic load should be defined in terms of a finite decrease in PWC from the maximum value to 10% of that value. Inspection of plastic strain contour plots indicated that at this load the gross plastic deformation mechanism was almost fully established.

The thinner heads exhibited more complex load-curvature, with multiple local maxima or peaks in PWC curve. These are each associated with the formation of plastic zones in different regions of the vessel and are dependent on the material model and deformation theory used in the analysis. The PWC criterion assumes that an increase in curvature from zero to a maximum then back to zero or near zero indicates formation of a gross plastic collapse mechanism. Consequently, the plastic pressure must be determined with respect to the first local maxima or peak. This is a conservative assumption but is common in design practice. It is well known that thin torispherical heads can support loads greatly in excess of the plastic load postulated in design before ductile rupture or tearing occurs but such high loads are not appropriate in design.

The values of plastic load given by the TES and PWC depended on the type of analysis performed and, in the former case, the deformation parameter used. In the small deformation perfectly plastic analyses, both the TES and PWC criterion plastic loads were similar to the limit loads of the heads. These results demonstrate that the

PWC definition of gross plastic deformation is consistent with the limit analysis definition. In the large deformation perfectly plastic analyses, the PWC criterion plastic loads are higher than TES criterion loads, except for Head 3 with deformation parameter located on the main cylinder. The cylinder deformation parameter was considered for Head 3 for comparison with the result given in Reference [17]. However, the cylinder parameter would be expected to characterise plastic deformation of the cylinder and not necessarily the head. The PWC criterion specifically identifies gross plastic deformation of the knuckle before plastic deformation of the main cylinder occurs, characterised by the second peak in Figure 9. In all Heads, the PWC criterion indicates gross plastic deformation at loads considerably lower than the numerical instability load.

In the small deformation strain hardening analyses, the TES criterion gave plastic loads similar to the limit load, indicating that the criterion does not significantly represent the effect of the material model on the spread of plastic deformation. The plastic loads evaluated using the PWC criterion, were consistently greater than the limit load. In large deformation strain hardening analysis, the PWC criterion gave plastic loads greater than the corresponding perfectly plastic analysis but less than or equal to the perfectly plastic instability load. The TES criterion plastic pressures were found to be dependant on the deformation parameter used. When a knuckle deformation parameter was used, the PWC criterion gave higher values of plastic load. When deformation parameters at the crown of the head or in the cylinder were used, the TES criterion gave similar or greater plastic pressures for Head 1 and Head 3.

In conclusion, the investigation of the torispherical heads has shown that the PWC criterion suitably characterises the complex elastic-plastic response of the components and is an appropriate method for calculating plastic pressures.

- The local maxima in the PWC plot are associated with specific plastic deformation mechanisms. In small deformation analyses, plastic collapse is clearly due to bending in the knuckle. In the large deformation analyses, knuckle bending is followed by extensive plastic membrane deformation in the spherical crown or in the cylindrical shell and the peaks in PWC corresponding to these events dominate the normalised PWC curve. These dominant peaks do not signify the onset of gross plastic deformation: this occurs in the knuckle prior to their formation (indeed, the membrane response is only possible after the knuckle changes shape).
- The sample analyses indicate that the PWC criterion leads to higher calculated plastic pressures and consequently design loads for strain hardening structures than the TES criterion but in comparison with limit and instability loads the PWC criterion is conservative. Enhanced design loads are given as the PWC criterion identifies the effect of a strain hardening material model on the evolution of the gross plastic deformation mechanism. The TES criterion evaluates similar plastic loads for perfectly plastic and strain hardening analysis.
- The PWC criterion may result in complex load-PWC curves with several local maxima when several plastic mechanisms form. However, the underlying criterion identifies the first peak as the significant event in the formation of a

gross plastic deformation mechanism. The plastic load is defined by considering the decrease in PWC from this local maxima to near zero (it is proposed that 10% of the maximum is a conservative definition of formation of the mechanism) or the minimum point between the first and second peak. This method gives a consistent definition of plastic pressure and is not dependant on choice of suitable deformation parameters which may or may not adequately describe the plastic response.

References

- [1] **BSI**, PD5500 Unfired fusion welded pressure vessels. *British Standards Institution*, London, 1999.

- [2] **ASME**, ASME Boiler and Pressure Vessel Code Sections III and VIII. *The American Society of Mechanical Engineers*, New York, NY, 2003.

- [3] **CES**, EN 13445-3:2002 Unfired pressure vessels. *European Committee for Standardisation*, Brussels, April 2002.

- [4] **ASME**, Criteria of the ASME Boiler and Pressure Vessel Code for Design by Analysis in Sections III and VIII, Division 2. *The American Society of Mechanical Engineers*, New York, 1969. Reprinted in Pressure Vessel Design and Analysis - A Decade of Progress. *The American Society of Mechanical Engineers*, New York, 1972.

[5] **Staat, M., Heitzer, M., Lang, H. and Wirtz, K.**, Direct finite element route for design-by-analysis of pressure components. *Int. J. of Pressure Vessels and Piping*, 2005, **82**, 61-67.

[6] **Gerdeen, J.C.**, A critical evaluation of plastic behaviour data and a united definition of plastic loads for pressure vessel components. *WRC Bulletin*, 1979, **254**.

[7] **Kirkwood, M.G. and Moffat, D.G.**, Plastic loads for piping branch junctions subjected to combined pressure and in-plane moment loads. *Proc. Instn Mech Engrs ImechE, Part E, Journal of Process Mechanical Engineering*, 1994, **208**, 31-43.

[8] **Mackenzie, D., Boyle, J.T., Hamilton, R.**, Application of inelastic finite element analysis to pressure vessel design. *8th ICPVT*, Montreal, 1996, **2**, 109-115.

[9] **Moffat, D.G., Hsieh, M.F. and Lynch, M.**, An assessment of ASME III and CEN TC54 methods of determining plastic and limit loads for pressure system components. *J. Strain Analysis*, 2001, **36** (3), 301-312.

[10] **Robertson, A., Li, H. and Mackenzie, D.**, Plastic collapse of pipe bends under combined internal pressure and in-plane bending, *Int. J. Pres. Ves. & Piping*, 2005, **80**, 407-416.

[11] **Lee K.S., Moreton D.N. and Moffat D.G.**, The plastic work required to induce the limit pressure of a plain cylinder, *Int. J. Pres. Ves. & Piping*, 2005, **82**, 115-121.

[12] **Muscat, M., Mackenzie, D. and Hamilton, R.** A work Criterion for Plastic Collapse, *Int. J. of Pressure Vessel and Piping*, 2003, **80**, 49-58.

[13] **Li, H. and Mackenzie, D.**, Characterising Gross Plastic Deformation in Design by Analysis. In Press, *Int. J. Pres. Ves. & Piping*, 2005, **82**, 777-786.

[14] **Mackenzie, D. and Li, H.**, A Plastic Load Criterion for Inelastic Design by Analysis. *Proc. ASME Pressure Vessel & Piping Conf.*, Denver, 2005, PVP2005-71556.

[15] **Yamamoto, Y., Asada, S. and Okamoto, A.**, Round robin calculations of collapse loads – a torispherical pressure vessel head with a conical transition, *J Pres Ves Tech*, 1997, **119**, 503-509.

[16] **Blachut, J.**, Plastic loads for internally pressurised torispheres, *Int. J. of Pressure Vessel and Piping*, 1994, **64**, 91-100.

[17] **Sanal, Z.**, Nonlinear analysis of pressure vessels: some examples, *Int. J. of Pressure Vessel and Piping*, 2000, **77**, 705-709.

[18] **Galletly, G.D. and Blachut, J.**, Torispherical shells under internal pressure – failure due to asymmetric plastic buckling or axisymmetric yielding, *Proc Instn Mech Engrs, No C3*, 1985, **199**, 225 – 238.

[19] **ANSYS** version 9.0, 2005

[20] Weisstein, E.W. Circumradius. From *MathWorld*--A Wolfram Web Resource.

<http://mathworld.wolfram.com/Circumradius.html>

List of tables:

Table 1: Geometric dimensions of pressure vessel heads

Table 2: Material properties for limit load analysis

Table 3: Bilinear material models

Table 4: Head 1, $D/t = 28.67$, plastic pressures

Table 5: Head 2, $D/t = 34.33$, plastic pressures

Table 6: Head 3, $D/t = 162.6$, plastic pressures

Table 7: Head 4, $D/t = 300$, plastic pressures

List of figures:

Figure 1: Twice elastic slope criterion of plastic collapse

Figure 2: Plastic work criterion

Figure 3: Plastic work curvature criterion

Figure 4: Example torispherical head geometry

Figure 5: Axisymmetric finite element mesh for Head 1

Figure 6: PWC criterion (a) evaluation of curvature from circumradius of three points (b) plot of normalised curvature against applied load, identifying load corresponding to reduction to 10% of maximum curvature.

Figure 7: Head 1 large deformation theory pressure-plastic work curves (a) perfectly plastic material $\sigma_y = 1.5S_m = 276 \text{ MN/m}^2$ (b) bilinear hardening material $\sigma_y = 370 \text{ MN/m}^2$.

Figure 8: Head 1 large deformation theory curvature versus load, plastic strain evolution (a) elastic-perfectly plastic (b) bilinear hardening.

Figure 9: Head 3 elastic perfectly plastic large deformation analysis (a) pressure-plastic work curve (b) PWC and plastic strain evolution.

Figure 10: Head 3 elastic-perfectly plastic, large deformation TES criterion applied to knuckle, crown and cylinder.

Figure 11: Head 4 elastic perfectly plastic material model PWC criterion.

Figure 12: Head 4 bilinear material model PWC criterion

Figure 13: Head 4 large deformation bilinear hardening analysis PWC plot for first mechanism only

<i>Dimensions</i>	<i>Head 1</i>	<i>Head 2</i>	<i>Head 3</i>	<i>Head 4</i>
D : cylinder outside diameter (mm)	6450.0	206.00	1870.0	3000.0
R_s : sphere radius (mm)	4612.5	160.0	1875.8	3000.0
t_c : cylinder thickness (mm)	225.00	---	7.20	10.00
t : sphere thickness (mm)	225.00	6.00	11.5	10.00
r : knuckle radius (mm)	472.50	30.80	192.75	450.00
L_c : Conical transition length	658.2	---	---	---
Semi-angle of spherical portion ϕ ($^\circ$)	30.000	32.385	26.115	24.193
L : Modelled length of cylinder (mm)	3000.0	---	750.0	3000.0
D/t	28.67	34.33	162.6(260)	300

Table 1: Geometric dimensions of pressure vessel heads

Head	1	2	3	4
Yield strength (MN/m ²)	276	300	265	310
Young's modulus (GN/m ²)	175	210	200	207

Table 2: Material properties for limit load analysis

Head	1	2	3	4
Yield strength (MN/m ²)	370	300	265	310
Young's modulus (GN/m ²)	175	210	200	207
Plastic modulus (GN/m ²)	3.341	1.000	1.000	1.000

Table 3: Bilinear material models

Plastic Criterion	Plastic Pressure (MN/m ²)			
	Small deformation theory		Large deformation theory	
	Elastic–perfect plastic	Bilinear hardening	Elastic–perfect plastic	Bilinear hardening
Limit Load	21.6	---	---	---
Instability	---	---	23.0	---
TES(knuckle)	20.0	28.0	20.8	29.1
TES(crown)	20.8	29.6	21.9	31.5
PWC	21.1	30.9	22.1	31.4
Reference [15] TES	21.3*	31.9**	21.4*	32.7**

*Apex deflection deformation parameter

+ Multi linear plasticity model

Table 4: Head 1, D/t= 28.67, plastic pressures

Plastic Criterion	Plastic Pressure (MN/m ²)			
	Small deformation theory		Large deformation theory	
	Elastic–perfect plastic	Bilinear hardening	Elastic–perfect plastic	Bilinear hardening
Limit Load	22.2	---	---	---
Instability	---	---	27.4	---
TES(knuckle)	21.5	21.6	22.3	22.3
TES(crown)	21.8	22.0	22.4	22.5
PWC	21.8	23.5	23.8	27.5
Reference [16] TES	n/a	n/a	22.4*	n/a

*Apex deflection deformation parameter.

Table 5: Head 2, D/t= 34.33, plastic pressures

Plastic Criterion	Plastic Pressure (MN/m ²)			
	Small deformation theory		Large deformation theory	
	Elastic–perfect plastic	Bilinear hardening	Elastic–perfect plastic	Bilinear hardening
Limit Load	1.59	---	---	---
Instability	---	---	2.43	---
TES(knuckle)	1.49	1.50	1.70	1.70
TES(crown)	1.53	1.54	1.82	1.84
TES (cylinder)	n/a	2.38	2.35	2.37
PWC	1.57	1.73	2.12	2.12
Reference [17] TES	n/a	n/a	n/a	2.52 ⁰⁺

⁰ Cylinder symmetry axis deformation parameter

⁺ Multi linear plasticity model

Table 6: Head 3, D/t= 162.6, plastic pressures

Plastic Criterion	Plastic Pressure (MN/m ²)			
	Small deformation theory		Large deformation theory	
	Elastic–perfect plastic	Bilinear hardening	Elastic–perfect plastic	Bilinear hardening
Limit Load	1.20	---	---	---
Instability	---	---	2.38	---
TES(knuckle)	1.16	1.17	1.49	1.50
TES(crown)	1.16	1.17	1.64	1.68
PWC	1.19	1.56	1.79	1.84
Reference [18] TES	n/a	n/a	1.64*	n/a

*Apex deflection deformation parameter.

⁺ Multi linear plasticity model

Table 7: Head 4, D/t= 300, plastic pressures

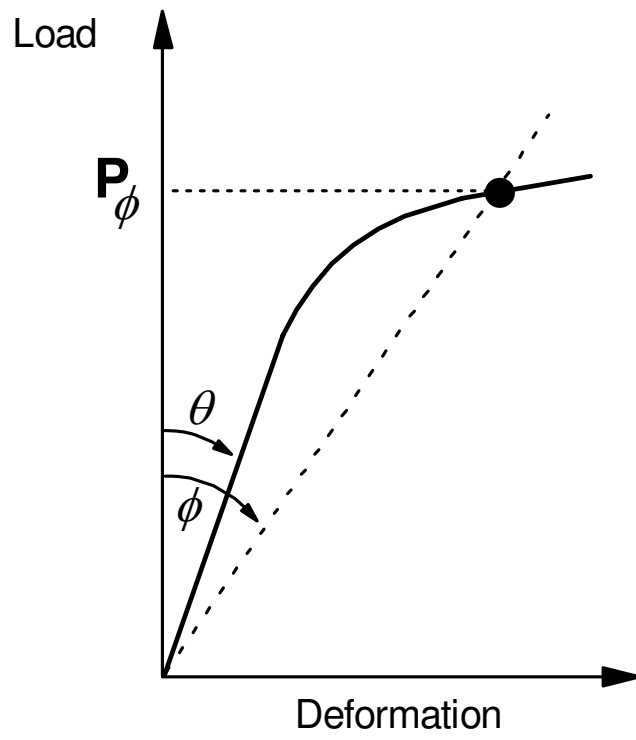

Figure 1: Twice elastic slope criterion of plastic collapse

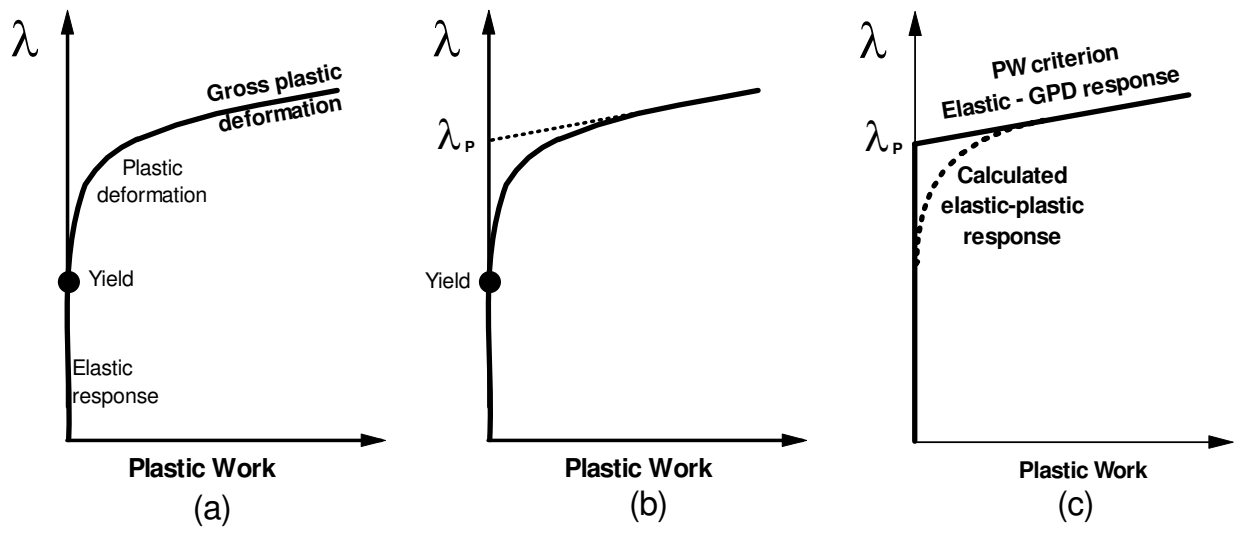

Figure 2: Plastic work criterion.

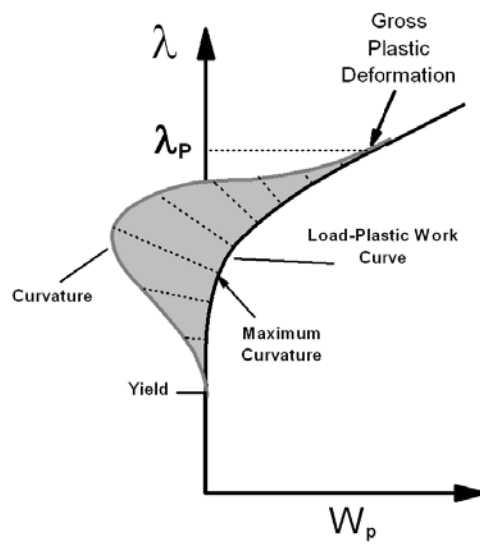
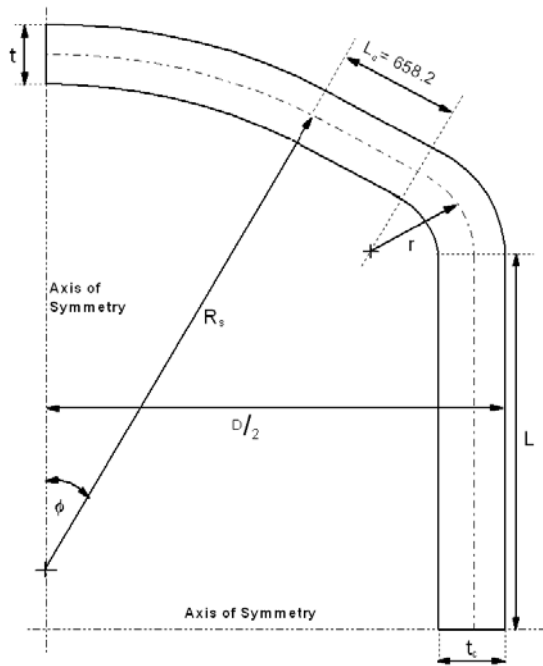
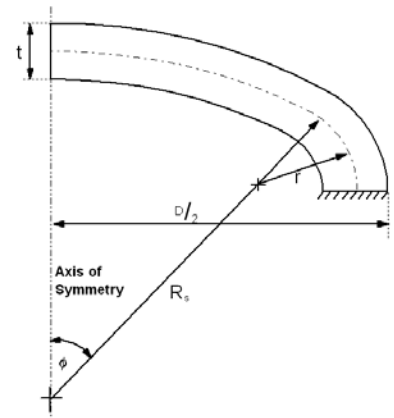

Figure 3: Plastic work curvature criterion



a) Head 1



b) Head 2

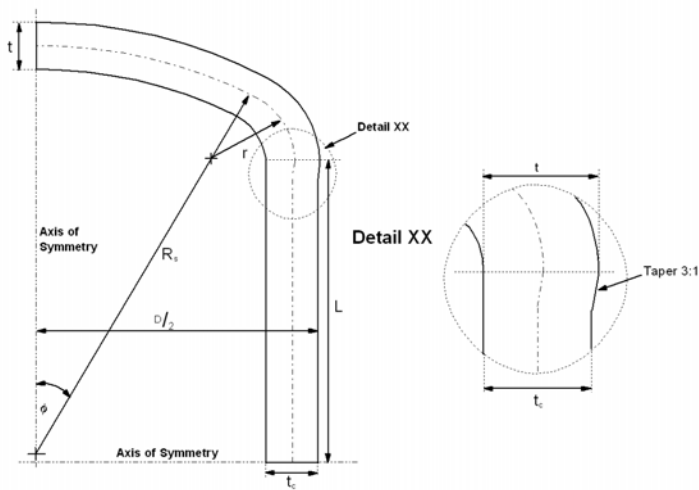

c) Head 3

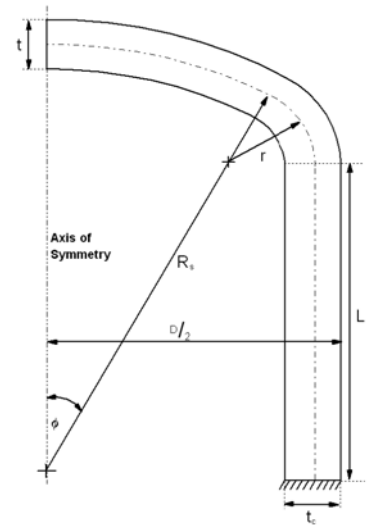

d) Head 4

Figure 4: Example torispherical head geometry

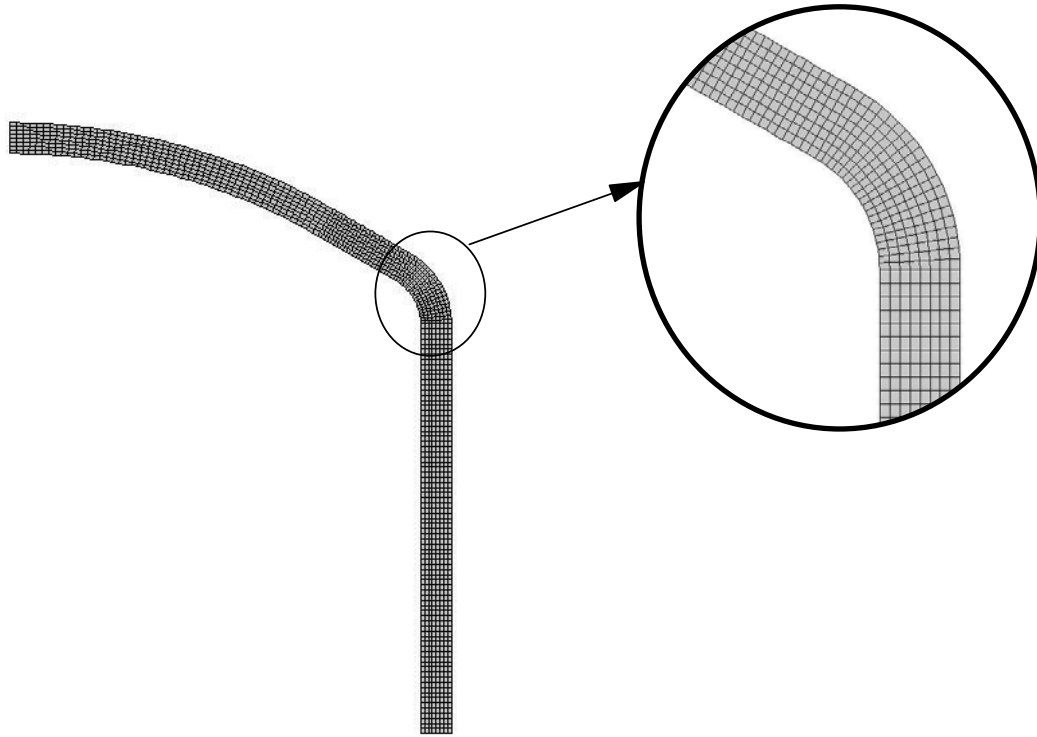

Figure 5: Axisymmetric finite element mesh for Head 1

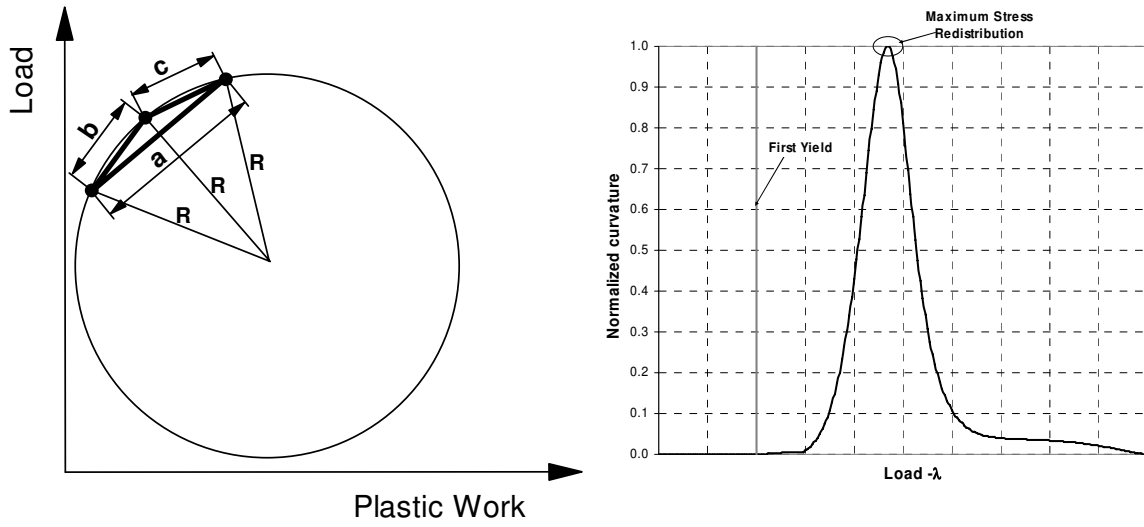
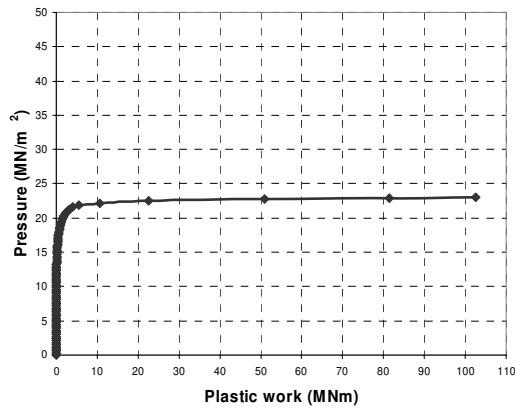
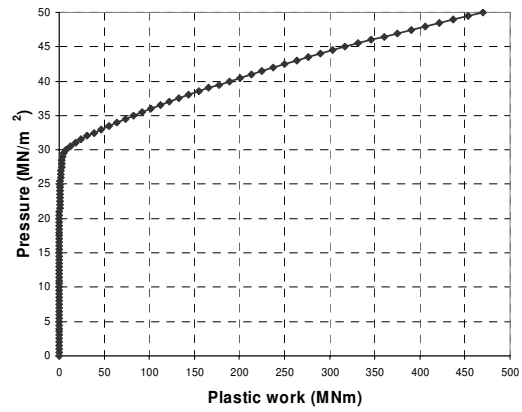

Figure 6: PWC criterion (a) evaluation of curvature from circumradius of three points (b) plot of normalised curvature against applied load, identifying load corresponding to reduction to 10% of maximum curvature.



(a)



(b)

Figure 7: Head 1 large deformation theory pressure-plastic work curves (a) perfectly plastic material $\sigma_y = 1.5S_m = 276 \text{ MN/m}^2$ (b) bilinear hardening material $\sigma_y = 370 \text{ MN/m}^2$.

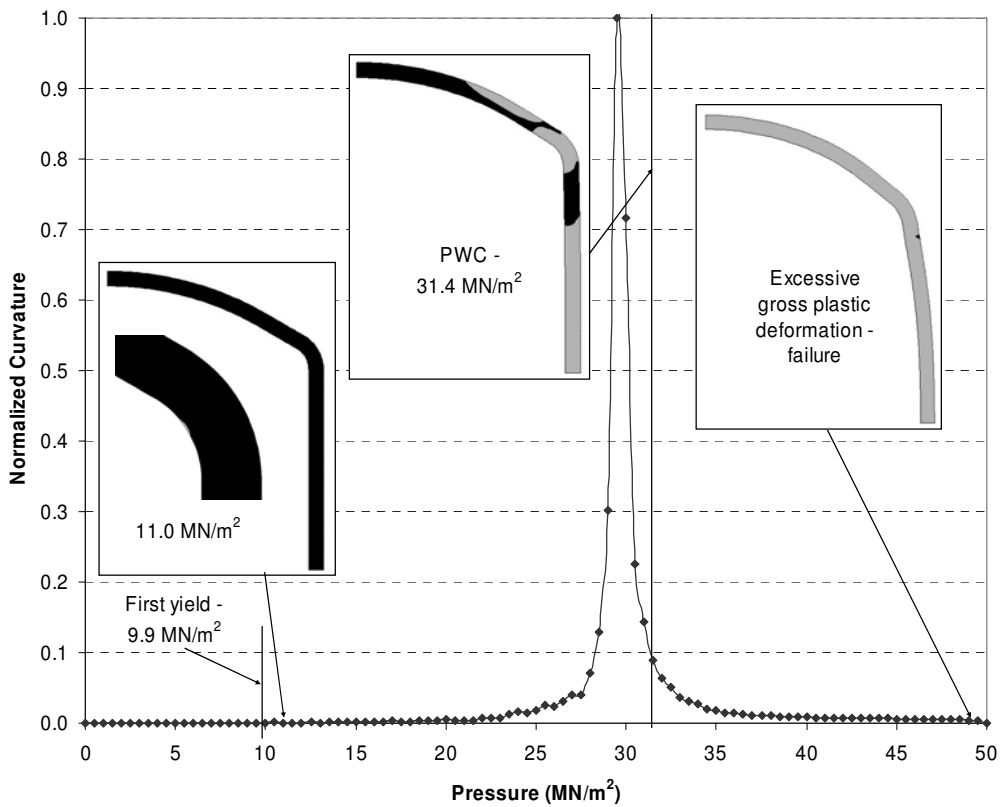
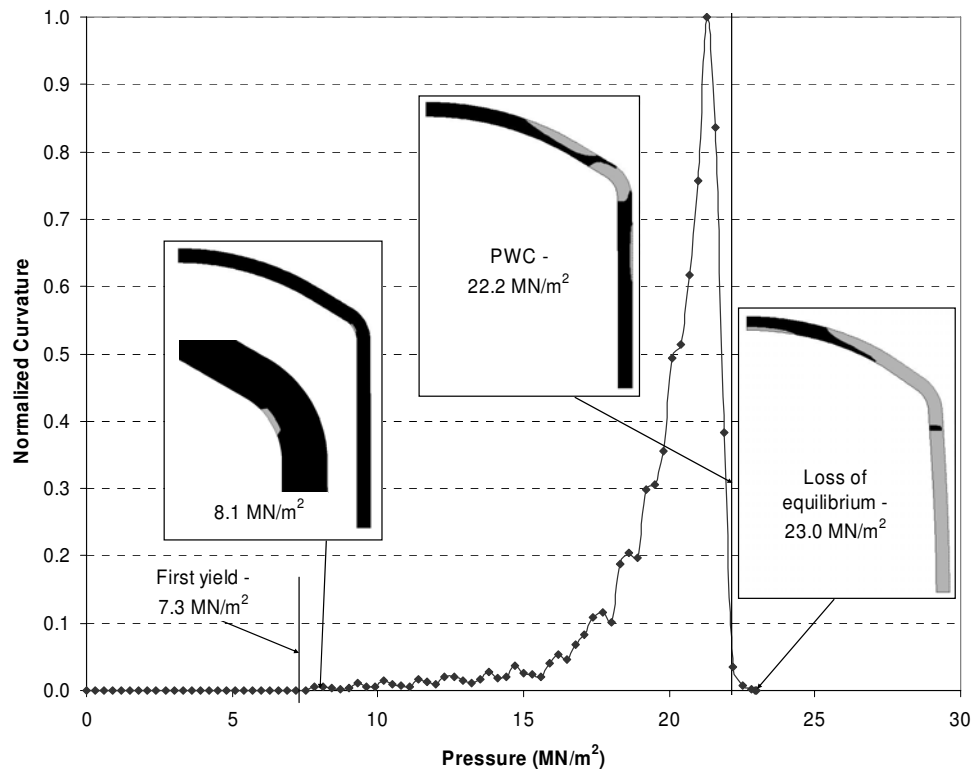
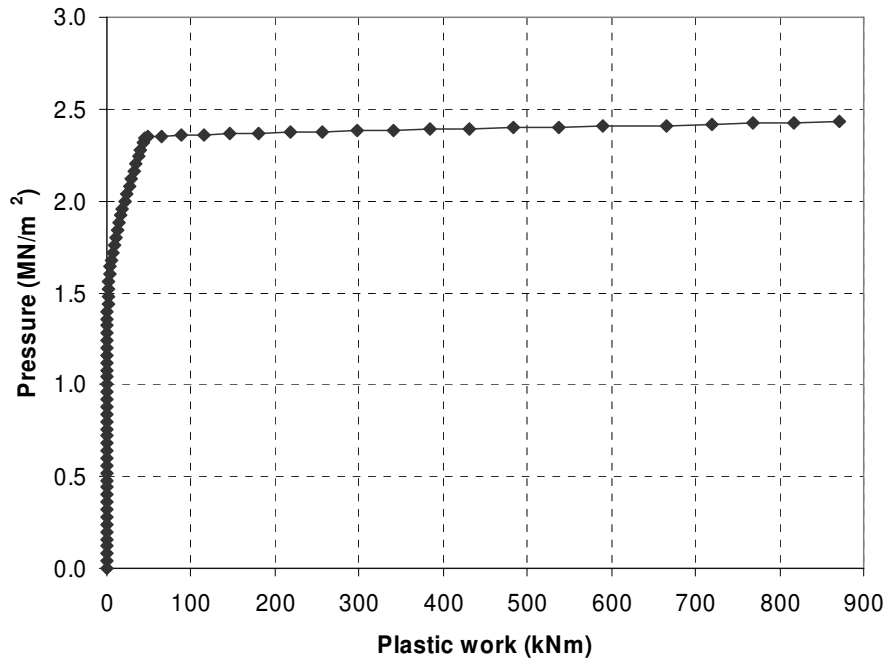
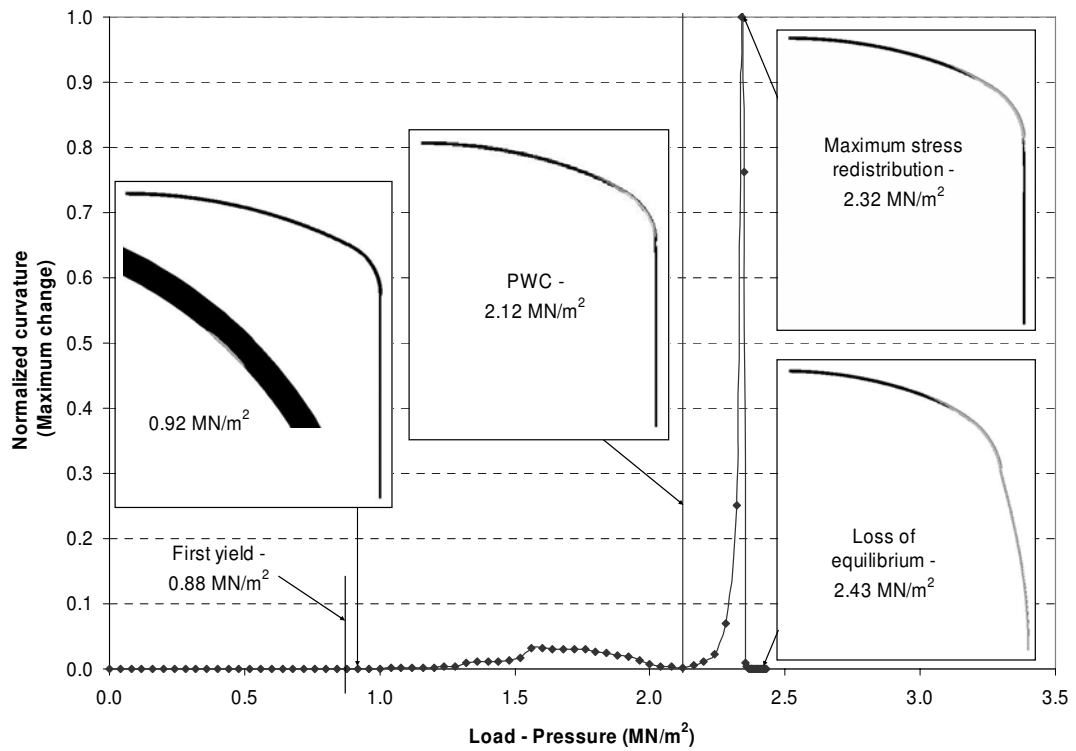

Figure 8: Head 1 large deformation theory curvature versus load, plastic strain evolution (a) elastic-perfectly plastic (b) bilinear hardening.



a) Pressure versus plastic work



b) Normalized curvature versus pressure

Figure 9: Head 3 elastic perfectly plastic large deformation analysis (a) pressure-plastic work curve (b) PWC and plastic strain evolution.

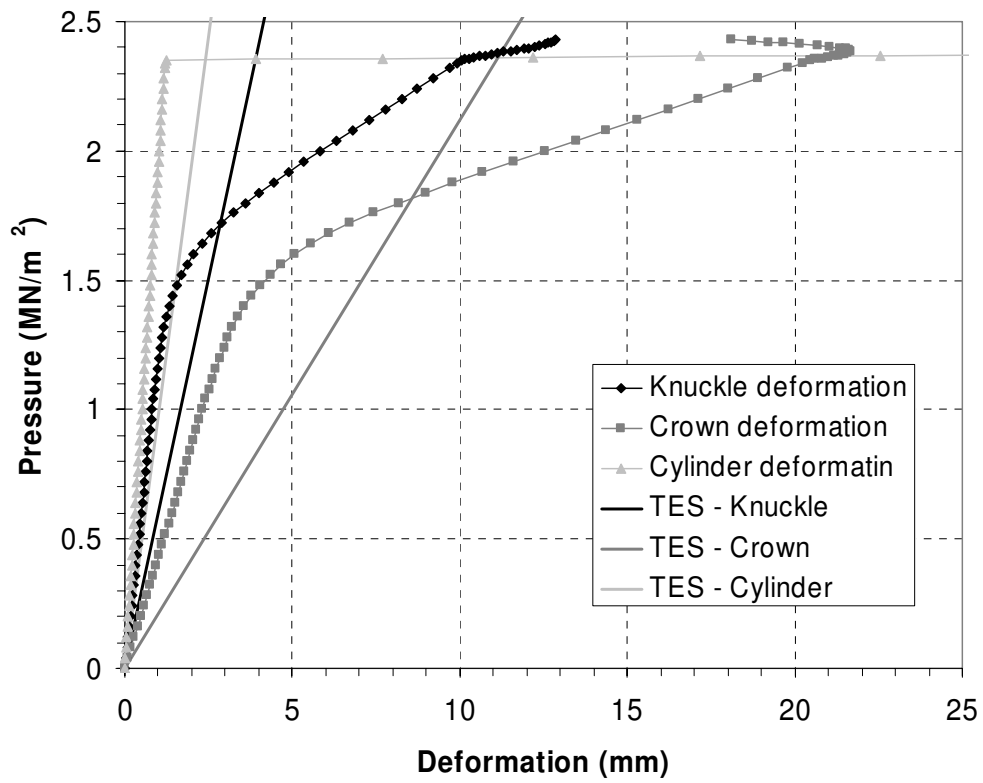
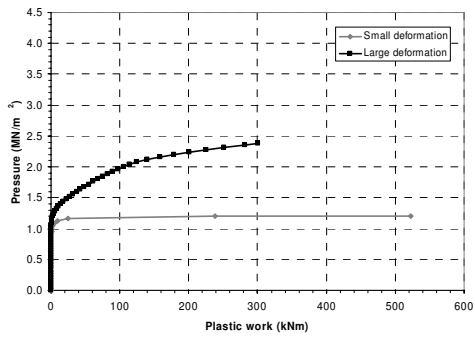
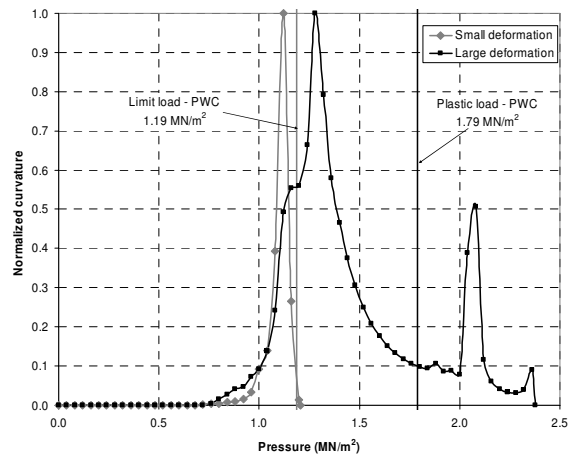

Figure 10: Head 3 elastic-perfectly plastic, large deformation TES criterion applied to knuckle, crown and cylinder.



a) Pressure versus plastic work



b) Curvature versus pressure

Figure 11: Head 4 elastic perfectly plastic material model PWC criterion.

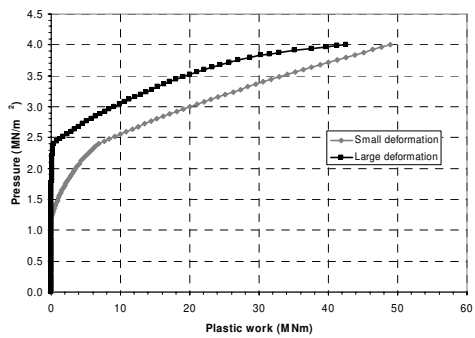

a) Pressure versus plastic work

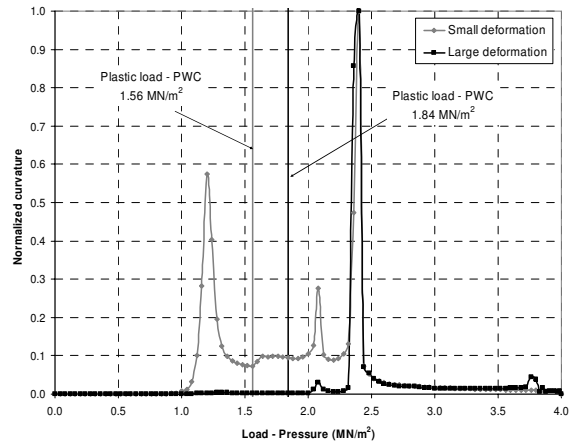

b) Curvature versus pressure

Figure 12: Head 4 bilinear material model PWC criterion

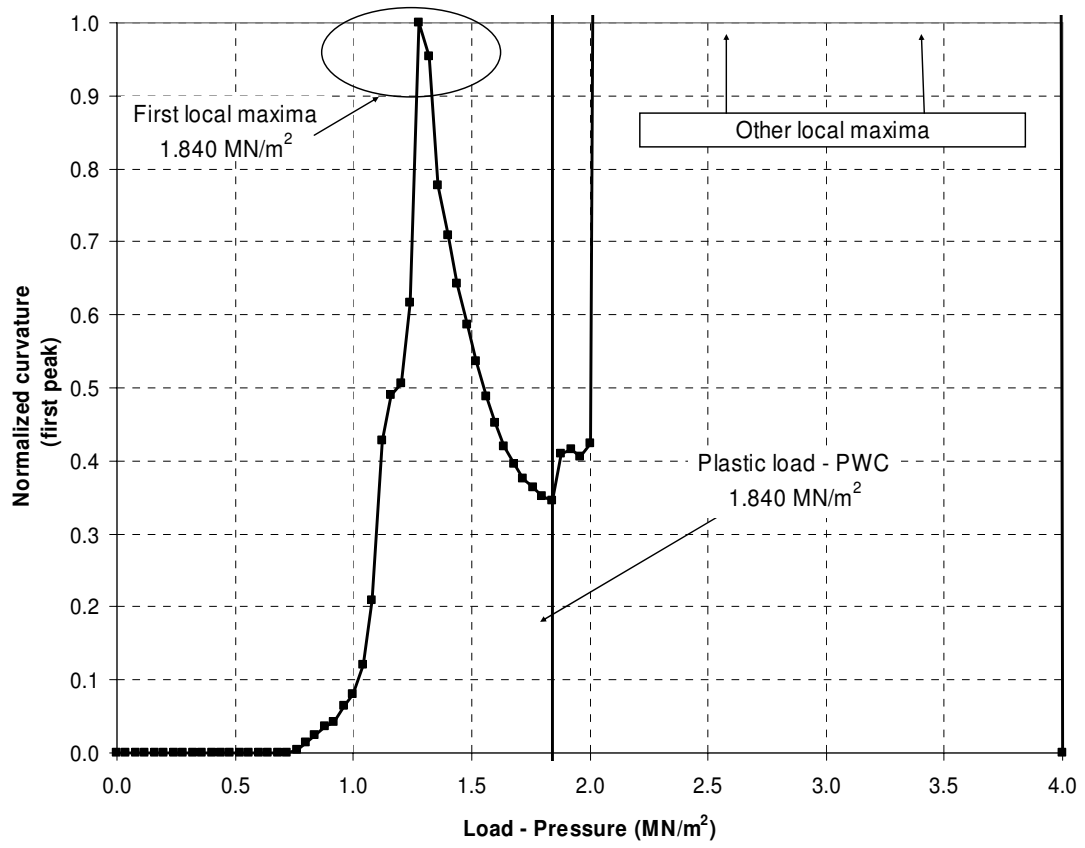

Figure 13: Head 4 large deformation bilinear hardening analysis PWC plot for first mechanism only